

1/10 ELECTRIC OFF-ROAD BUGGY 2WD

XRAY XB2

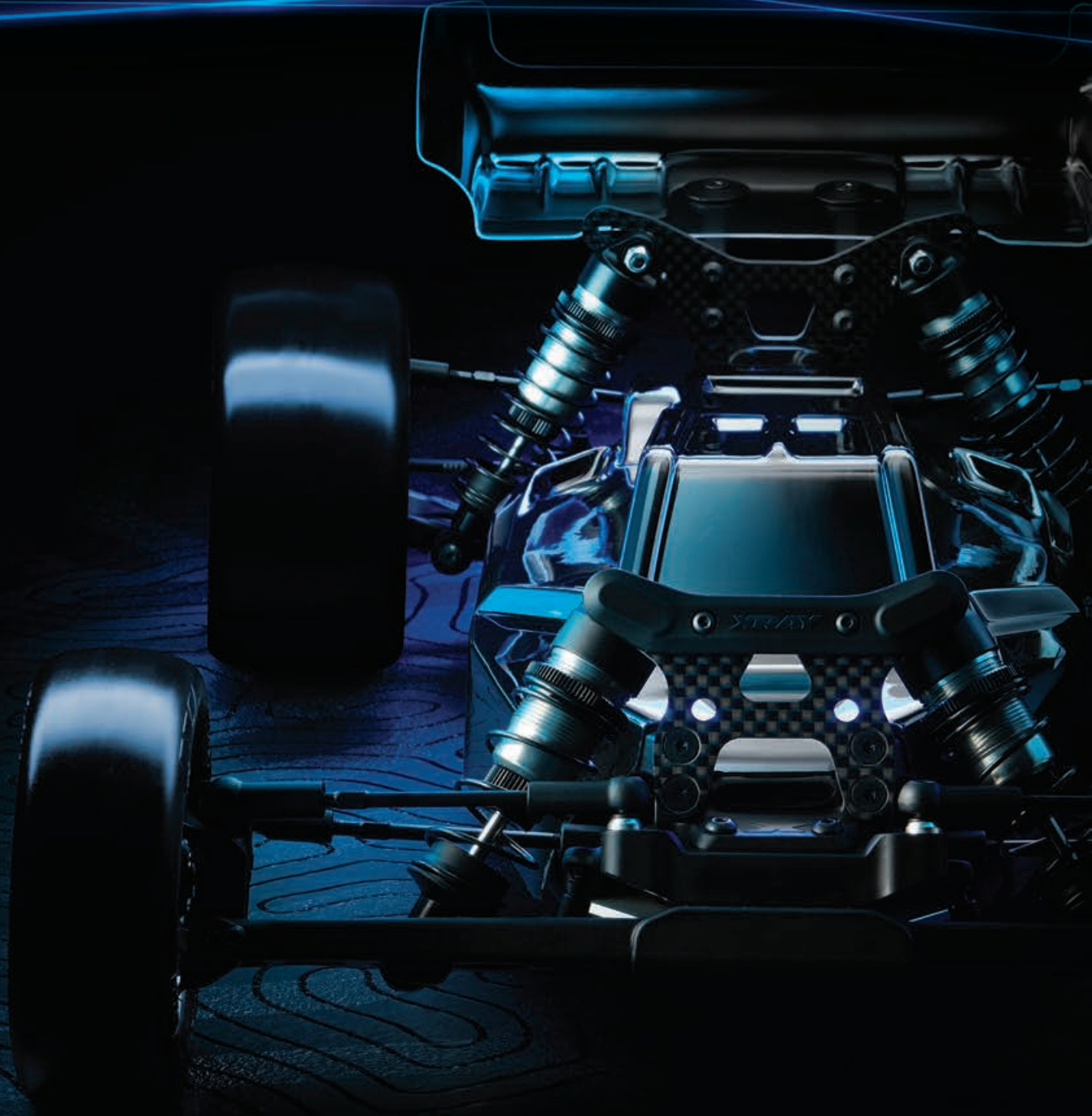

INSTRUCTION MANUAL
FOR XB2D'25 EDITION

BEFORE YOU START

This is a high-competition, high-quality RC car intended for persons aged 16 years and older with previous experience building and operating RC model racing cars. This is NOT a toy; it is a precision racing model. This model racing car is NOT intended for use by beginners, inexperienced customers, or by children without direct supervision of a responsible, knowledgeable adult. If you DO NOT fulfill these requirements, please return the kit in unused and unassembled form back to the shop where you have purchased it.

Before building and operating your XRAY, **YOU MUST** read through all of the operating instructions and instruction manual and fully understand them to get the maximum enjoyment and prevent unnecessary damage.

CUSTOMER SUPPORT

We have made every effort to make these instructions as easy to understand as possible. However, if you have any difficulties, problems, or questions, please DO NOT hesitate to contact the XRAY support team at info@teamxray.com. Also, please visit our Web site at www.teamxray.com to find the latest updates, set-up information, option parts, and many other goodies. We pride ourselves on taking excellent care of our customers.

You can join thousands of XRAY fans and enthusiasts in our online community at: www.teamxray.com

Read carefully and fully understand the instructions before beginning assembly.

Make sure you review this entire manual, download and use set-up book from the web, and examine all details carefully. If for some reason you decide this is NOT what you wanted or expected, **DO NOT continue any further**. Your hobby dealer can NOT accept your kit for return or exchange after it has been partially or fully assembled.

Contents of the box may differ from pictures. In line with our policy of continuous product development, the exact specifications of the kit may vary without prior notice.

XRAY Europe

K Vystavisku 6992
91101 Trenčín
Slovakia, EUROPE
Phone: 421-32-7401100
Fax: 421-32-7401109
E-mail: info@teamxray.com

XRAY USA

RC America, 2030 Century Center Blvd #15 Irving,
TX 75062
USA
Phone: (214) 744-2400
Fax: (214) 744-2401
E-mail: xray@rcamerica.com

FAILURE TO FOLLOW THESE INSTRUCTIONS WILL BE CONSIDERED AS ABUSE AND/OR NEGLIGENCE.

SAFETY PRECAUTIONS

Contains:

LEAD (CAS 7439-92-1) ANTIMONY (CAS 7440-36-0)

WARNING: This product contains a chemical known to the state of California to cause cancer and birth defects or other reproductive harm.

CAUTION: CANCER HAZARD

Contains lead, a listed carcinogen. Lead is harmful if ingested. Wash thoroughly after using. DO NOT use product while eating, drinking or using tobacco products. May cause chronic effects to gastrointestinal tract, CNS, kidneys, and blood. **MAY CAUSE BIRTH DEFECTS.**

When building, using and/or operating this model always wear protective glasses and gloves.

Take appropriate safety precautions prior to operating this model. You are responsible for this model's assembly and safe operation! Please read the instruction manual before building and operating this model and follow all safety precautions. Always keep the instruction manual at hand for quick reference, even after completing the assembly. Use only genuine and original

authentic XRAY parts for maximum performance. Using any third party parts on this model will void warranty immediately.

Improper operation may cause personal and/or property damage. XRAY and its distributors have no control over damage resulting from shipping, improper construction, or improper usage. XRAY assumes and accepts no responsibility for personal and/or property damages resulting from the use of improper building materials, equipment and operations. By purchasing any item produced by XRAY, the buyer expressly warrants that he/she is in compliance with all applicable federal, state and local laws and regulation regarding the purchase, ownership and use of the item. The buyer expressly agrees to indemnify and hold harmless XRAY for all claims resulting directly or indirectly from the purchase, ownership or use of the product. By the act of assembling or operating this product, the user accepts all resulting liability. If the buyer is NOT prepared to accept this liability, then he/she should return this kit in new, unassembled, and unused condition to the place of purchase.



IMPORTANT NOTES – GENERAL

- This product is NOT suitable for children under 16 years of age without the direct supervision of a responsible and knowledgeable adult.
 - Carefully read all manufacturers warnings and cautions for any parts used in the construction and use of your model.
 - Assemble this kit only in places away from the reach of very small children.
 - First-time builders and users should seek advice from people who have building experience in order to assemble the model correctly and to allow the model to reach its performance potential.
 - Exercise care when using tools and sharp instruments.
 - Take care when building, as some parts may have sharp edges.
 - Keep small parts out of reach of small children. Children must NOT be allowed to put any parts in their mouth, or pull vinyl bag over their head.
 - Read and follow instructions supplied with paints and/or cement, if used (NOT included in kit).
 - Immediately after using your model, DO NOT touch equipment on the model such as the motor and speed controller, because they generate high temperatures. You may seriously burn yourself seriously touching them.
 - Follow the operating instructions for the radio equipment at all times.
 - DO NOT put fingers or any objects inside rotating and moving parts, as this may cause damage or serious injury as your finger, hair, clothes, etc. may get caught.
 - Be sure that your operating frequency is clear before turning on or running your model, and never share the same frequency with somebody else at the same time. Ensure that others are aware of the operating frequency you are using and when you are using it.
 - Use a transmitter designed for ground use with RC cars. Make sure that no one else is using the same frequency as yours in your operating area. Using the same frequency at the same time, whether it is driving, flying or sailing, can cause loss of control of the RC model, resulting in a serious accident.
 - Always turn on your transmitter before you turn on the receiver in the car. Always turn off the receiver before turning your transmitter off.
 - Keep the wheels of the model off the ground when checking the operation of the radio equipment.
 - Disconnect the battery pack before storing your model.
 - When learning to operate your model, go to an area that has no obstacles that can damage your model if your model suffers a collision.
 - Remove any sand, mud, dirt, grass or water before putting your model away.
 - If the model behaves strangely, immediately stop the model, check and clear the problem.
 - To prevent any serious personal injury and/or damage to property, be responsible when operating all remote controlled models.
 - The model car is NOT intended for use on public places and roads or areas where its operation can conflict with or disrupt pedestrian or vehicular traffic.
 - Because the model car is controlled by radio, it is subject to radio interference from many sources that are beyond your control. Since radio interference can cause momentary loss of control, always allow a safety margin in all directions around the model in order to prevent collisions.
 - DO NOT use your model:
 - Near real cars, animals, or people that are unaware that an RC car is being driven.
 - In places where children and people gather
 - In residential districts and parks
 - In limited indoor spaces
 - In wet conditions
 - In the street
 - In areas where loud noises can disturb others, such as hospitals and residential areas.
 - At night or anytime your line of sight to the model may be obstructed or impaired in any way.
- To prevent any serious personal injury and/or damage to property, please be responsible when operating all remote controlled models.

IMPORTANT NOTES – ELECTRICAL

- Insulate any exposed electrical wiring (using heat shrink tubing or electrical tape) to prevent dangerous short circuits. Take maximum care in wiring, connecting and insulating cables. Make sure cables are always connected securely. Check connectors for if they become loose. And if so, reconnect them securely. Never use RC models with damaged wires. A damaged wire is extremely dangerous, and can cause short-circuits resulting in fire. Please have wires repaired at your local hobby shop.
- Low battery power will result in loss of control. Loss of control can occur due to a weak battery in either the transmitter or the receiver. Weak running battery may also result in an out of control car if your car's receiver power is supplied by the running battery. Stop operation immediately if the car starts to slow down.
- When NOT using RC model, always disconnect and remove battery.
- DO NOT disassemble battery or cut battery cables. If the running battery short-circuits, approximately 300W of electricity can be discharged, leading to fire or burns. Never disassemble battery or cut battery cables.
- Use a recommended charger for the receiver and transmitter batteries and follow the instructions correctly. Over-charging, incorrect charging, or using inferior chargers can

cause the batteries to become dangerously hot. Recharge battery when necessary. Continual recharging may damage battery and, in the worst case, could build up heat leading to fire. If battery becomes extremely hot during recharging, please ask your local hobby shop for check and/or repair and/or replacement.

- Regularly check the charger for potential hazards such as damage to the cable, plug, casing or other defects. Ensure that any damage is rectified before using the charger again. Modifying the charger may cause short-circuit or overcharging leading to a serious accident. Therefore DO NOT modify the charger.
- Always unplug charger when recharging is finished.
- DO NOT recharge battery while battery is still warm. After use, battery retains heat. Wait until it cools down before charging.
- DO NOT allow any metal part to short circuit the receiver batteries or other electrical/electronic device on the model.
- Immediately stop running if your RC model gets wet as may cause short circuit.
- Please dispose of batteries responsibly. Never put batteries into fire.

R/C & BUILDING TIPS

- Make sure all fasteners are properly tightened. Check them periodically.
- Make sure that chassis screws DO NOT protrude from the chassis.
- For the best performance, it is very important that great care is taken to ensure the free movement of all parts.
- Clean all ball-bearings so they move very easily and freely.
- Tap or pre-thread the plastic parts when threading screws.
- Self-tapping screws cut threads into the parts when being tightened. DO NOT use excessive force when tightening the self-tapping screws because you may strip out the thread in the plastic. We recommended you stop tightening a screw when you feel some resistance.

- Ask your local hobby shop for any advice.

Please support your local hobby shop. We at XRAY Model Racing Cars support all local hobby dealers. Therefore we ask you, if at all possible, to purchase XRAY products at your hobby dealer and give them your support like we do.

If you have difficulty finding XRAY products, please check out www.teamxray.com to get advice, or contact us via email at info@teamxray.com, or contact the XRAY distributor in your country.

WARRANTY

XRAY guarantees this model kit to be free from defects in both material and workmanship within 30 days of purchase. The total monetary value under warranty will in no case exceed the cost of the original kit purchased. This warranty DOES NOT cover any components damaged by use or modification or as a result of wear. Part or parts missing from this kit must be reported within 30 days of purchase. No part or parts will be sent under warranty without proof of purchase. Should you find a defective or missing part, contact the local distributor. Service and customer support will be provided through local hobby store where you have purchased the kit, therefore make sure to purchase any XRAY products at your local hobby store. This model racing car is considered to be a high-performance racing vehicle. As such this vehicle will be used in an extreme range of conditions and situations, all which may cause premature wear or failure of any component. XRAY has no control over usage of vehicles once they leave the dealer, therefore XRAY can only offer warranty against all manufacturer's defects in materials, workmanship, and assembly at point of sale and before use. No warranties are expressed or implied that cover damage caused by what is considered normal use, or cover or imply how long any model cars' components or electronic components will last before requiring replacement.

Due to the high performance level of this model car you will need to periodically maintain and replace consumable components. Any and all warranty coverage will NOT cover replacement of any part or component damaged by neglect, abuse, or improper or unreasonable use. This includes but is NOT limited to damage from crashing, chemical and/or water damage, excessive moisture, improper or no maintenance, or user modifications which compromise the

integrity of components. Warranty will NOT cover components that are considered consumable on RC vehicles. XRAY DOES NOT pay nor refund shipping on any component sent to XRAY or its distributors for warranty. XRAY reserves the right to make the final determination of the warranty status of any component or part.

LIMITATIONS OF LIABILITY.

XRAY makes no other warranties expressed or implied. XRAY shall NOT be liable for any loss, injury or damages, whether direct, indirect, special, incidental, or consequential, arising from the use, misuse, or abuse of this product and/or any product or accessory required to operate this product. In no case shall XRAY's liability exceed the monetary value of this product.

Take adequate safety precautions prior to operating this model. You are responsible for this model's assembly and safe operation.

Disregard of the any of the above cautions may lead to accidents, personal injury, or property damage.

XRAY MODEL RACING CARS assumes no responsibility for any injury, damage, or misuse of this product during assembly or operation, nor any addictions that may arise from the use of this product.

All rights reserved.

QUALITY CERTIFICATE

XRAY MODEL RACING CARS uses only the highest quality materials, the best compounds for molded parts and the most sophisticated manufacturing processes of TQM (Total Quality Management). We guarantee that all parts of a newly-purchased kit are manufactured with the highest regard to quality. However, due to the many factors inherent in model racecar

competition, we cannot guarantee any parts once you start racing the car. Products which have been worn out, abused, neglected or improperly operated will NOT be covered under warranty. We wish you enjoyment of this high-quality and high-performance RC car and wish you best success on the track!

In line with our policy of continuous product development, the exact specifications of the kit may vary. In the unlikely event of any problems with your new kit, you should contact the model shop where you purchased it, quoting the part number.

We do reserve all rights to change any specification without prior notice. All rights reserved.

TOOLS REQUIRED



Combination Pliers (HUDY #189020)

Side Cutters (HUDY #189010)

Pocket Hobby Knife (HUDY #188981)

Special Tool for turnbuckles, nuts (HUDY #181090)

Turnbuckle Wrench 3.5mm (HUDY #181035)

HUDY Tweezers Straight (HUDY #188970)

HUDY Tweezers Curved (HUDY #188971)

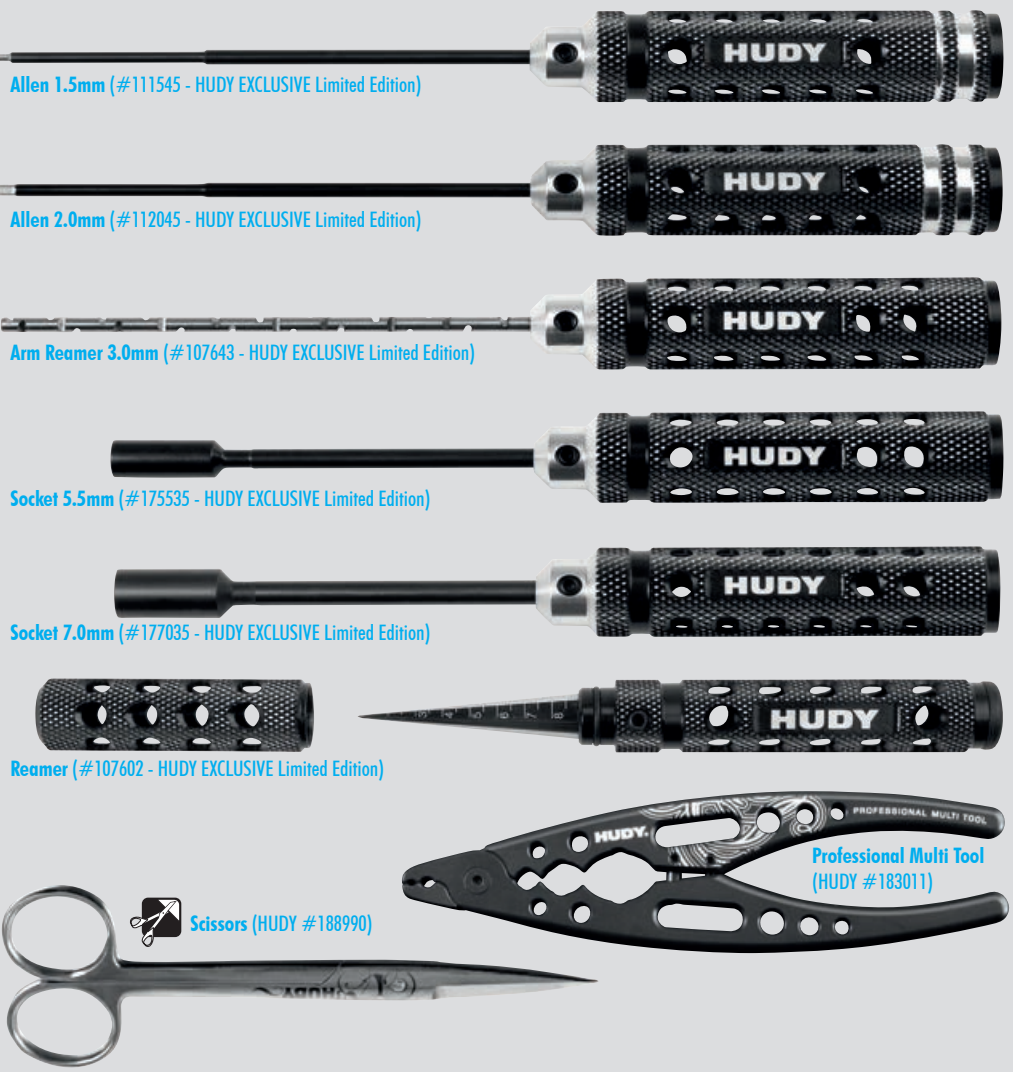

Allen 1.5mm (#111545 - HUDY EXCLUSIVE Limited Edition)

Allen 2.0mm (#112045 - HUDY EXCLUSIVE Limited Edition)

Arm Reamer 3.0mm (#107643 - HUDY EXCLUSIVE Limited Edition)

Socket 5.5mm (#175535 - HUDY EXCLUSIVE Limited Edition)

Socket 7.0mm (#177035 - HUDY EXCLUSIVE Limited Edition)

Reamer (#107602 - HUDY EXCLUSIVE Limited Edition)















Scissors (HUDY #188990)

Professional Multi Tool (HUDY #183011)

EQUIPMENT INCLUDED * Kit includes smaller but sufficient amount of oil and greases to build the car.

<p>300cSt Oil for assembly of front & rear shock absorbers.</p> 	<p>Premium Diff Grease Grease for use on ball differential.</p> 	<p>Premium Graphite Grease Grease for use on suspension & drivetrain maintenance.</p> 
--	--	---

EQUIPMENT REQUIRED

<p>Transmitter</p> 	<p>Receiver</p> 	<p>Speed Controller</p> 	<p>Steering Servo</p> 	<p>Electric Motor & Pinion Gear with Setscrew</p> 	<p>LiPo Battery</p> 
<p>Battery Charger</p> 	<p> Double-sided Tape (HUDY #107875)</p> 	<p>Lexan™ Paint</p> 	<p>4x Tires & Inserts</p> 	<p> Bearing Oil (HUDY #106230)</p> 	<p>Threadlock</p>  <p>CA glue</p> 

NOT INCLUDED



SAMPLE OF OPTIONAL PARTS

#32XXXX	TYPE1	OPTION 1
#32XXXX	TYPE2	OPTION 2
#32XXXX	TYPE	INCLUDED

XRAY offers wide range of optional tuning parts which are listed in a table like this. Please refer to the exploded view of each main section to verify which part is included in the kit while all other parts are available only as an optional part and must be purchased separately.

COLOR INDICATIONS

At the beginning of each section is an exploded view of the parts to be assembled. There is also a list of all the parts and part numbers that are related to the assembly of that section.

The part descriptions are color-coded to make it easier for you to identify the source of a part. Here are what the different colors mean:

- 321200** **STYLE A** - indicates parts that are included in the bag marked for the section.
- 321100** **STYLE B** - indicates parts that are included in the box.
- 324900** **STYLE C** - indicates parts that are already assembled from previous steps.
- 325100** **STYLE D** - indicates parts that are **OPTIONAL**.

TECH TIPS

TIP DRIVE SHAFT PIN SERVICING

To enjoy the longest possible lifespan of the drive shafts and diff outrives, it is extremely important to properly service the drive shaft pins. Inspect the pins after every 3 hours of runtime. If the pins show any wear, replace them with new pins.



DO NOT use drive shafts when the pins are worn.

Press out the worn pins.

Press in new pins and regularly inspect for wear.



For quick & easy drive pin replacements use **#106000 HUDY Drive Pin Replacement Tool** together with **#106036 Ejector Pivot Pin & Alternating Pivot 2.5mm**.



To replace the worn pins use only premium **HUDY drive pins** (**#106053 2.5mm dia x 10mm length**)

TIP CARBON PARTS PREPARATION

Follow this Tech Tip to prepare the carbon parts. Sand the edges with sandpaper, and then seal the edges with CA glue to reinforce them and help prevent delamination.

Prepare all Carbon Parts:

- Front shock tower
- Rear shock tower

Fine sandpaper

Use fine sandpaper to sand smooth the edges of all carbon parts.

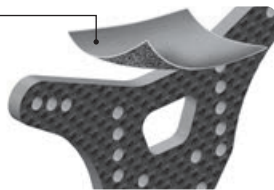

Apply CA glue to all edges of the carbon parts.

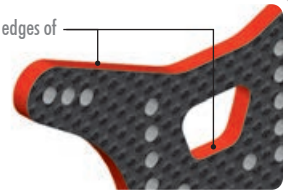

TIP

All ball-bearings are factory pre-oiled or pre-greased. The bearings of each type are packaged separately; there is a **BAG 00.9** with pre-greased ball-bearings and a separate bag with pre-oiled ball-bearings.

For pre-oiled ball-bearings, use: **#106230 HUDY Bearing Oil**.

For pre-greased ball-bearings with rubber covers, use one of these bearing greases:
#106220 - HUDY Bearing Grease - suggested for extremely dusty track conditions.
#106221 - HUDY Bearing Grease "Blue" - suggested for medium dusty track conditions.
#106222 - HUDY Bearing Grease "Red" - suggested for low dusty track conditions.

Replace any bearings that develop a "gritty" feeling to prevent inefficiency and avoid failures.

Make sure to use only original XRAY ball-bearings, which all have specific tolerances, axial and radial play, and are all individually selected. Using 3rd party ball-bearings may result in bearing failures and damage to other parts.

OPTION PARTS

HUDY PREMIUM SILICONE OILS



HUDY ULTIMATE SILICONE OILS		
#106510	10.000cSt - 50ml	OPTION
#106492	11.000cSt - 50ml	OPTION
#106512	12.000cSt - 50ml	OPTION
#106513	13.000cSt - 50ml	OPTION
#106515	15.000cSt - 50ml	OPTION
#106520	20.000cSt - 50ml	OPTION
#106530	30.000cSt - 50ml	OPTION
#106540	40.000cSt - 50ml	OPTION
#106550	50.000cSt - 50ml	OPTION
#106560	60.000cSt - 50ml	OPTION
#106580	80.000cSt - 50ml	OPTION
#106610	100.000cSt - 50ml	OPTION
#106615	150.000cSt - 50ml	OPTION

TIP TIPS FOR GEAR DIFFERENTIAL

LOW-MEDIUM TRACTION 30.000cSt
 MEDIUM-HIGH TRACTION 50.000cSt
 HIGH TRACTION 80.000cSt

Softer oil increases rear traction, harder oil increases on-power forward traction.

HUDY TITANIUM 5.4mm BALL STUDS

Ø 5.4mm



HUDY TITANIUM 4.9mm BALL STUDS

Ø 4.9mm



**TITANIUM MATERIAL SUPER LIGHTWEIGHT ULTRA-PRECISE
 LONG LIFE HIGH DURABILITY MADE BY HUDY
 MADE IN EUROPE**



1. BALL DIFFERENTIAL

#930220
CERAMIC BALL 2.4MM (12)
OPTION



Premium-quality ceramic balls made from extra-hard Si3N4 silicone nitride ceramic significantly improve differential lifespan while reducing friction.

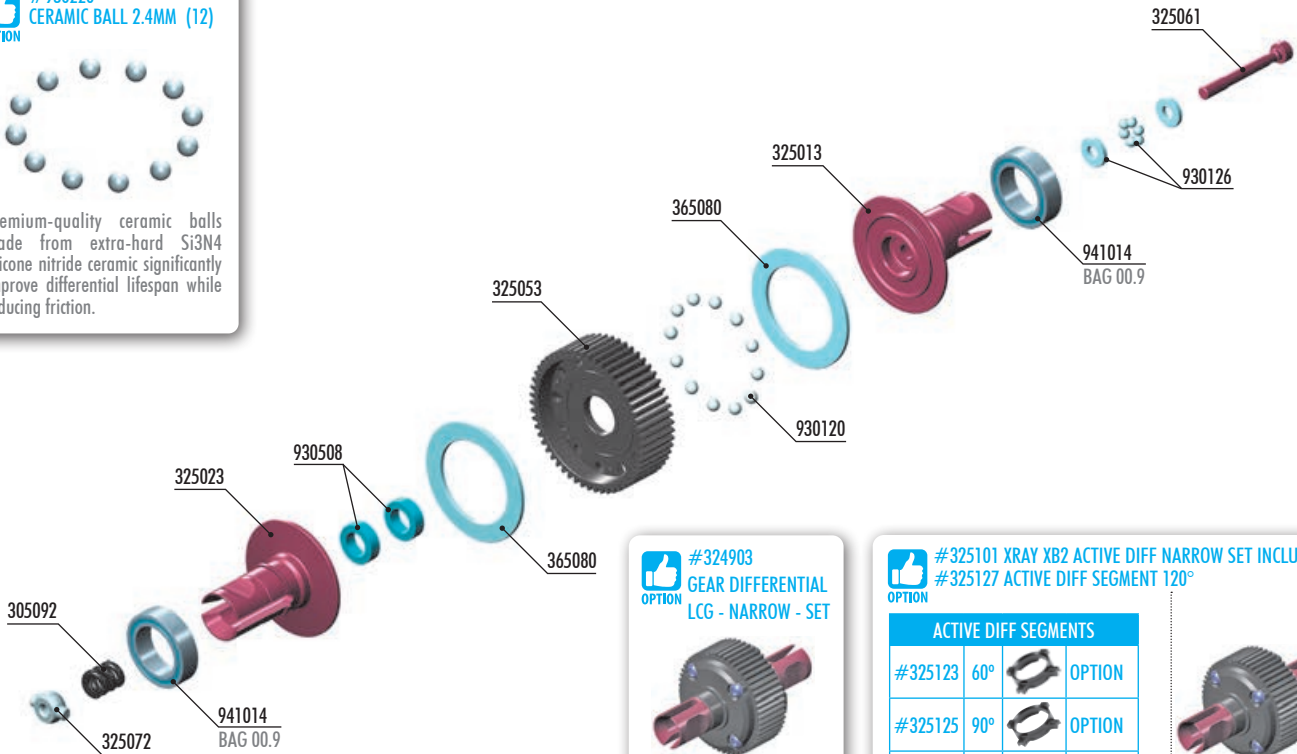

#324903
GEAR DIFFERENTIAL
LCG - NARROW - SET
OPTION



The gear differential is suggested for medium to high traction conditions as it increases on-power steering.

#325101 XRAY XB2 ACTIVE DIFF NARROW SET INCLUDING #325127 ACTIVE DIFF SEGMENT 120°
OPTION

ACTIVE DIFF SEGMENTS			
#325123	60°		OPTION
#325125	90°		OPTION
#325127	120°		OPTION



Adjustable Active Front Diff improves speed and handling. Different angled segments allow the diff gears to engage on-power to increase the forward traction, making it faster and easier to drive.

BAG

01

- 305092 BALL DIFFERENTIAL SPRING
- 325003 BALL ADJUSTABLE DIFFERENTIAL - LCG - SET - HUDY SPRING STEEL™
- 325013 BALL DIFFERENTIAL SHORT OUTPUT SHAFT - LCG - HUDY SPRING STEEL™
- 325023 BALL DIFFERENTIAL LONG OUTPUT SHAFT - LCG - HUDY SPRING STEEL™
- 325053 COMPOSITE BALL DIFFERENTIAL GEAR 53T
- 325061 SCREW FOR BALL DIFF ADJUSTMENT - SPRING STEEL™

- 325072 ALU BALL DIFFERENTIAL NUT
- 365080 DIFF WASHER 17 x 24.5 x 1 (2)
- 930120 CARBIDE BALL 2.4mm FOR BALL DIFF (12)
- 930126 CARBIDE BALL-BEARING AXIAL 2.6x6x1
- 930508 BALL-BEARING 5x8x2.5 STEEL SEALED - OIL (2)
- 941014 BALL-BEARING 10x15x4 RUBBER SEALED - GREASE (2)



1x 930126
BA 2.6x6x1

- 2.6 x 6 x 1mm axial shim
- 2.0mm carbide balls (6x)
- 2.6 x 6 x 1mm axial shim

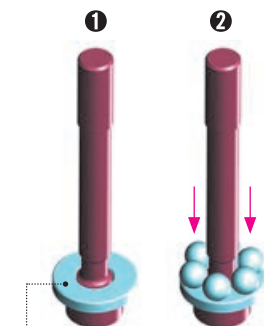

GRAPHITE GREASE
(HUDY #106210)

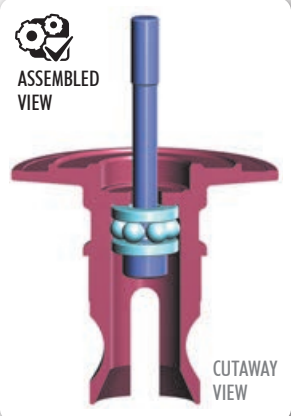

1. BALL DIFFERENTIAL



2x 930508
BB 5x8x2.5

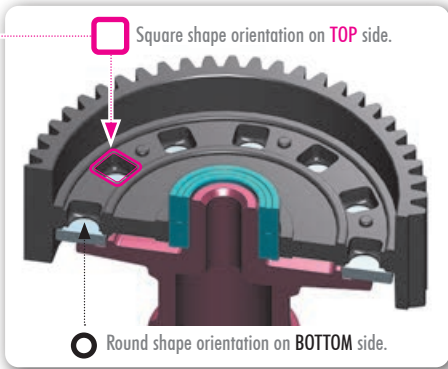

NOTE ORIENTATION

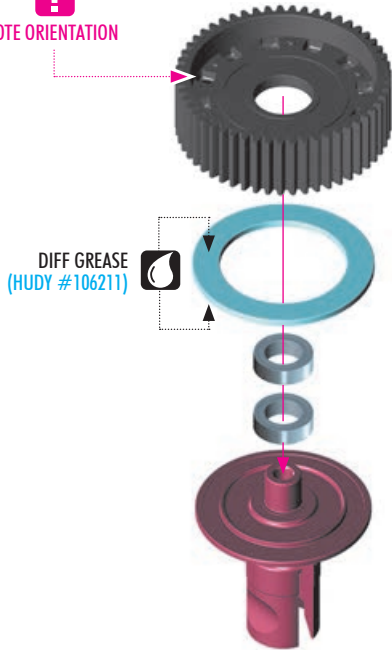

12x 930120
B 2.4

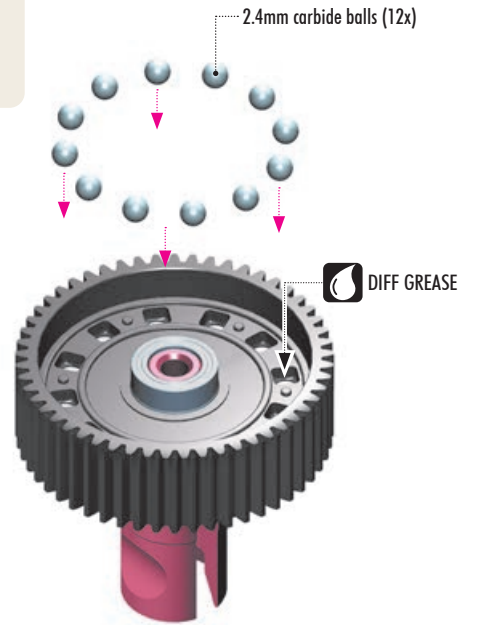

#930220
CERAMIC BALL 2.4MM (12)
OPTION



Premium-quality ceramic balls made from extra-hard Si3N4 silicone nitride ceramic significantly improve differential lifespan while reducing friction.



2x 941014
BB 10x15x4

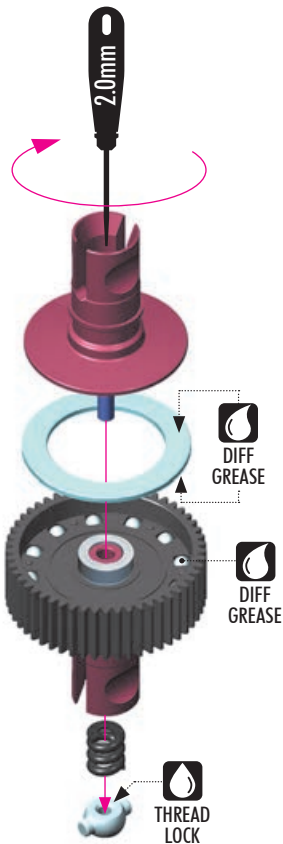

ASSEMBLED VIEW

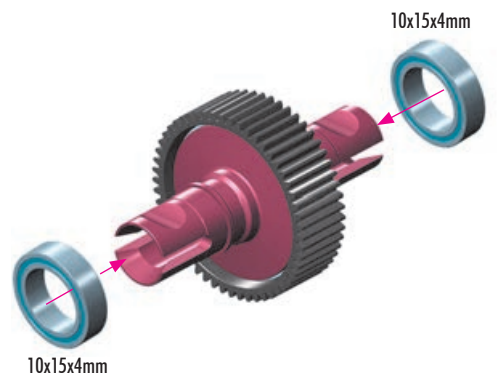
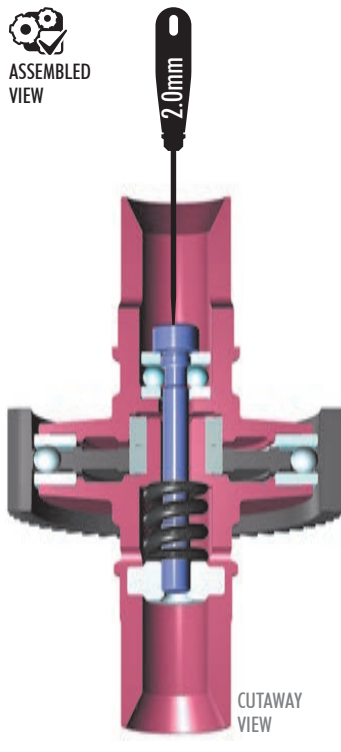

BALL DIFF BREAK-IN & SET-UP INFO



BEFORE RACING, follow these steps to properly break in the differential.

1

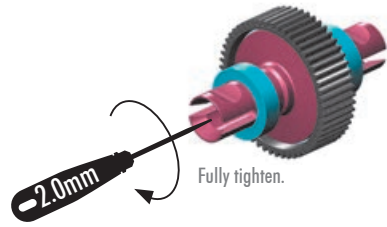

2 Loosen the adjustment screw 1/2 turn (180° CCW).

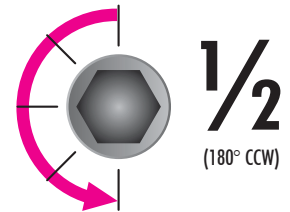
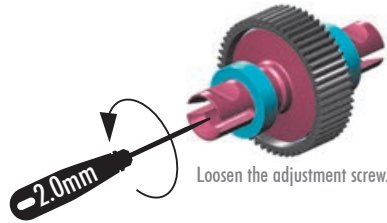

3

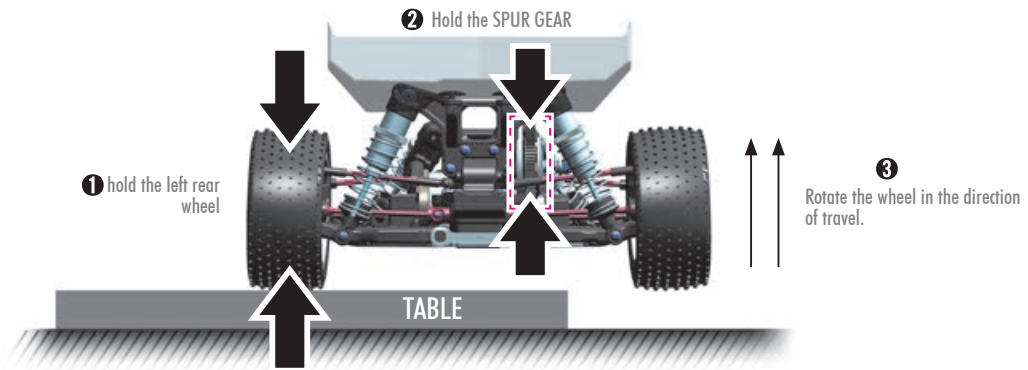

4

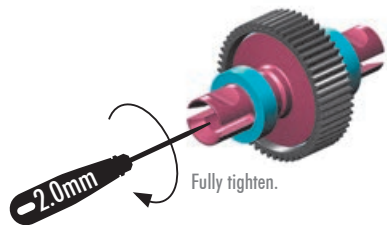

5 Loosen the adjustment screw 1/8 turn (45° CCW).

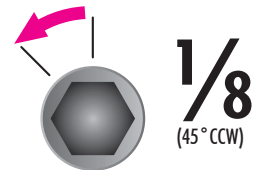
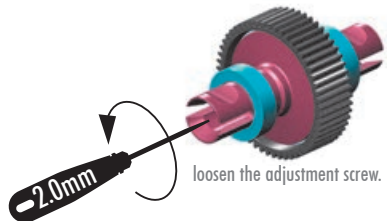

 INITIAL SETTING



Ball differential is now ready.

2. REAR TRANSMISSION

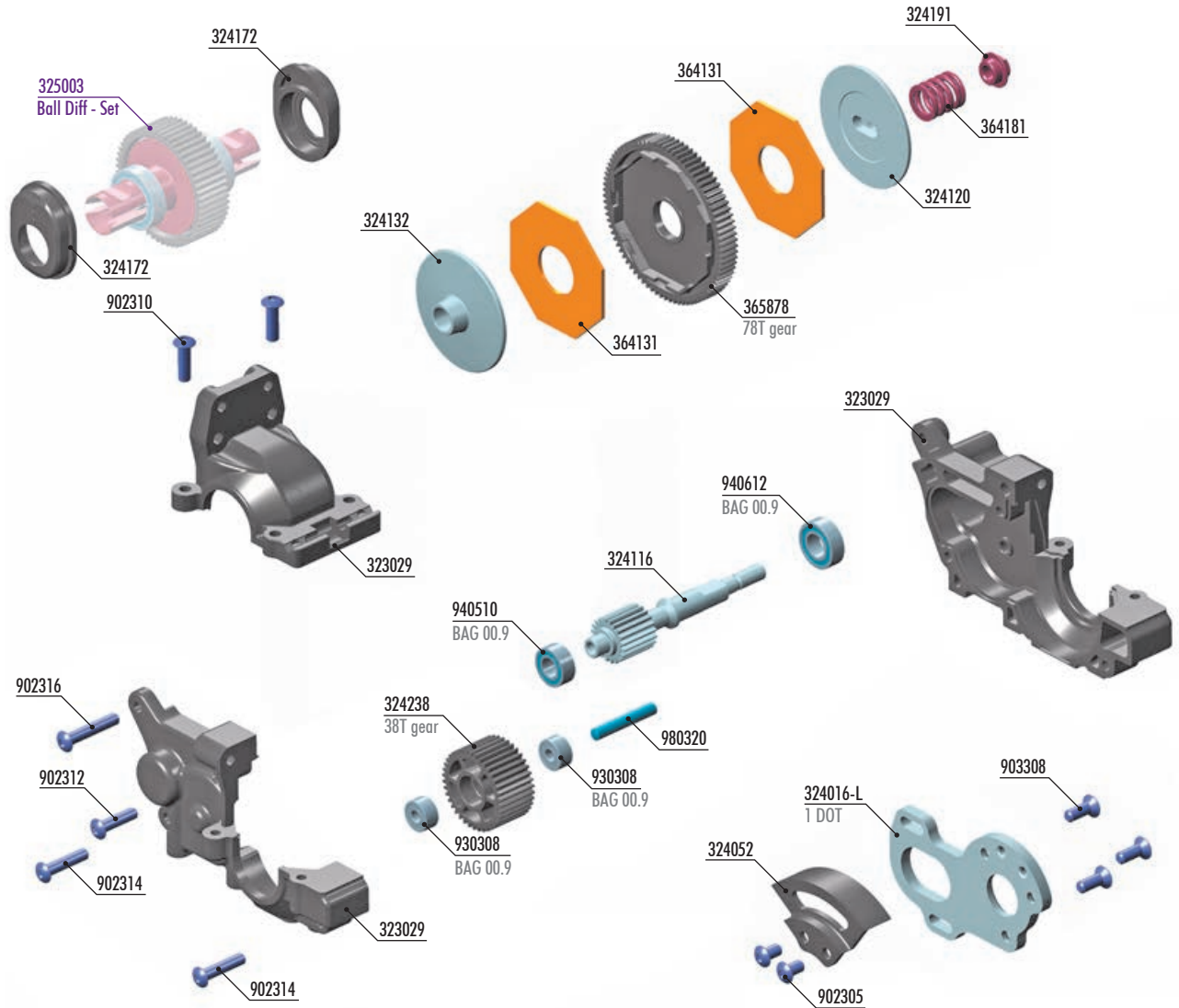

323029-G
GRAPHITE 3G GEAR BOX FOR
OPTION CHASSIS BRACE - SET



#320905
XB2 5G GEAR BOX CONVERSION SET
OPTION For assembly instructions see page 44.

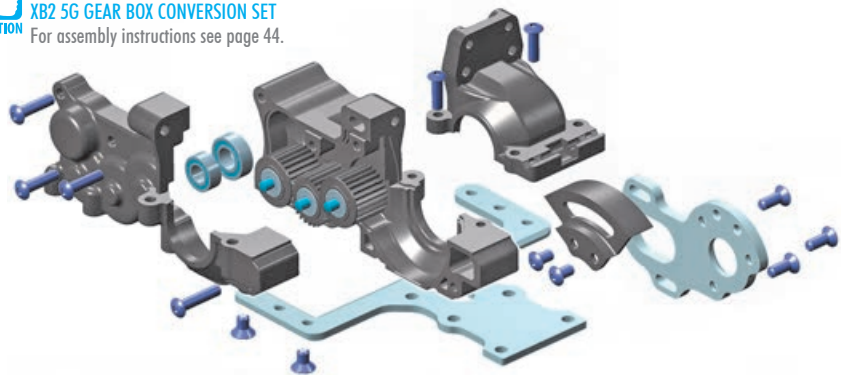

- 323029 COMPOSITE 3G GEAR BOX FOR CHASSIS BRACE - SET
- 324016-L ALU MOTOR PLATE FOR 3G GEAR BOX -1mm - 1-DOT - SWISS 7075 T6
- 324052 COMPOSITE GEAR COVER - LCG
- 324116 ALU 2-PAD TOP SHAFT 20T - LCG - ULTRA-LIGHTWEIGHT - SHORT
- 324120 ALU 3-PAD SLIPPER CLUTCH PLATE - SWISS 7075 T6 - HARD COATED
- 324172 ALU 2-PAD SLIPPER CLUTCH PLATE 31MM WITH ADAPTER - LCG - 7075 T6
- 324132 COMPOSITE ADJUSTMENT BALL-BEARING HUB (2)
- 324191 STEEL SLIPPER CLUTCH NUT - HUDY SPRING STEEL™
- 324238 COMPOSITE GEAR 38T - LCG - GRAPHITE
- 364131 SLIPPER CLUTCH PAD SLS - SOFT (3)
- 364181 SLIPPER CLUTCH SPRING C=45 - BLACK
- 365878 COMPOSITE 3-PAD SLIPPER CLUTCH SPUR GEAR 78T / 48

- 902305 HEX SCREW SH M3x5 (10)
- 902310 HEX SCREW SH M3x10 (10)
- 902312 HEX SCREW SH M3x12 (10)
- 902314 HEX SCREW SH M3x14 (10)
- 902316 HEX SCREW SH M3x16 (10)
- 903308 HEX SCREW SFH M3x8 (10)
- 930308 BALL-BEARING 3x8x4 STEEL SEALED - OIL (2)
- 940510 BALL-BEARING 5x10x4 RUBBER SEALED - OIL (2)
- 940612 BALL-BEARING 6x12x4 RUBBER SEALED - OIL (2)
- 980320 PIN 3x20 (10)

- 325003 BALL ADJUSTABLE DIFFERENTIAL - LCG - SET

2. REAR TRANSMISSION



2x 930308
BB 3x8x4

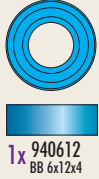

1x 940612
BB 6x12x4

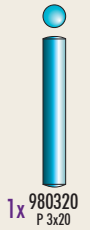

1x 980320
P 3x20

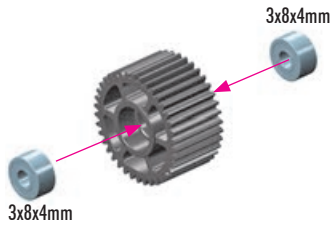

#980320-T
OPTION
TITANIUM PIN 3x20 (2)

Super lightweight ultra-precision hand ground titanium pins for high durability and long life. More than 40% lighter than steel.

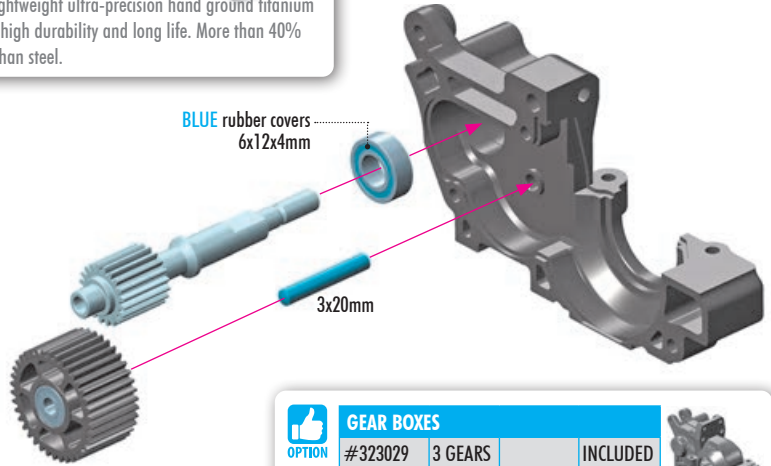

GEAR BOXES			
#323029	3 GEARS		INCLUDED
#323029-G	3 GEARS	GRAPHITE	OPTION



1x 940510
BB 5x10x4

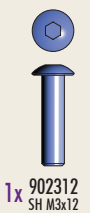
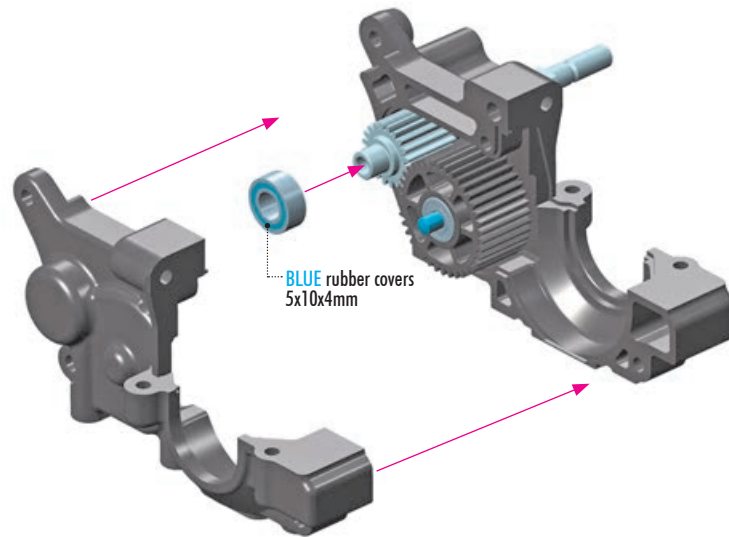

1x 902312
SH M3x12

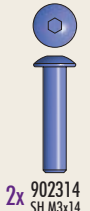

2x 902314
SH M3x14



1x 902316
SH M3x16

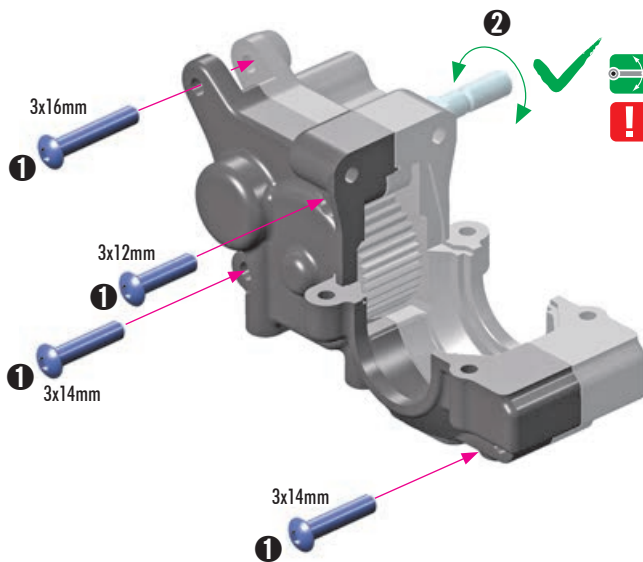

After assembly, check for free rotation.

The proper gear mesh will be achieved after final assembly on the chassis.

2. REAR TRANSMISSION

DIFFERENTIAL HEIGHT ADJUSTMENT

HIGHEST	HIGHER	MIDDLE	1 DOT	2 DOTS	3 DOTS
3 DOTS	2 DOTS	1 DOT	MIDDLE	LOWER	LOWEST

INITIAL SETTING (with checkmark icon)

NOTE ORIENTATION (with exclamation mark icon)
Dots must have same orientation on each side. For initial setting dots must be UP on both inserts.

3 DOTS NOTE ORIENTATION (with exclamation mark icon)

3 DOTS NOTE ORIENTATION (with exclamation mark icon)

Ball Diff

2x 902310 SH M3x10

GEAR RATIO
Internal Gear Ratio **2.65**

3x10mm ①

"CLICK"

NOTE ORIENTATION (with exclamation mark icon)
Dots must have same orientation on each side. For initial setting dots must be UP on both inserts.

NOTE DIFF ORIENTATION (with exclamation mark icon)
Ball differential must always be oriented with the screw on the right side. If the ball differential is oriented with the screw on the left side, the ball diff will become loose when the car is running.

LEFT **RIGHT**

GRAPHITE GREASE

② (with checkmark icon)
After assembly, check for free rotation of all drivetrain parts.

The proper gear mesh will be achieved after final assembly on the chassis. (with exclamation mark icon)

2x 902305 SH M3x5

3G Motor plate (-1mm) 1 Dot

3x5mm

NOTE ORIENTATION (with exclamation mark icon)

#324017 CARBON MOTOR PLATE LCG (with thumbs up icon and 'OPTION' label)

Lightweight carbon motor plate helps to reduce CG and absorbs vibrations from the motor.

2. REAR TRANSMISSION



3x 903308
SFH M3x8

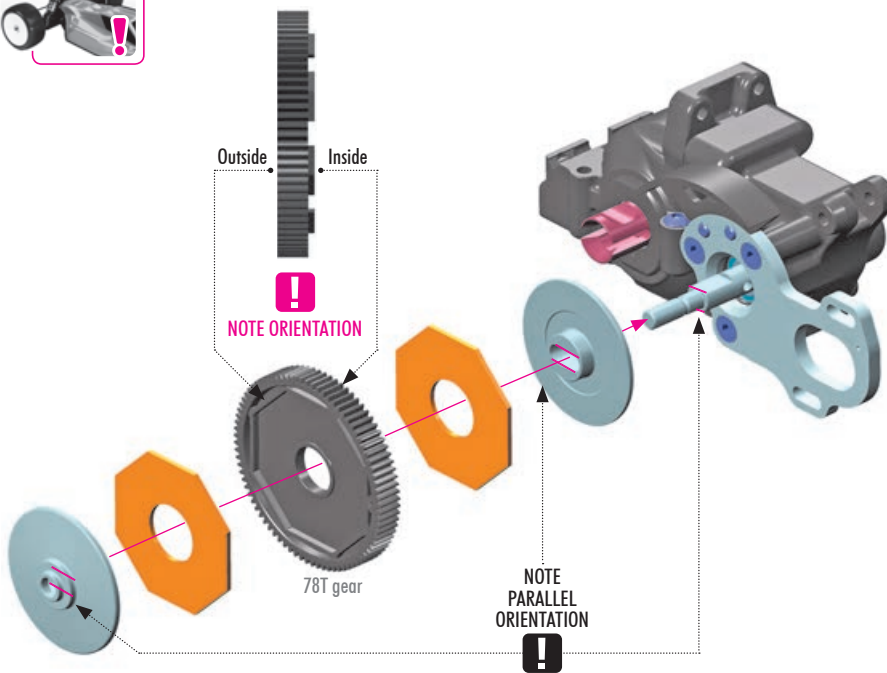
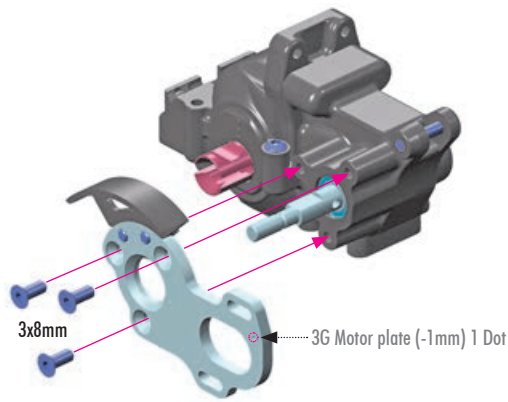

SPUR GEARS		
OPTION	#365872	72T OPTION
	#365875	75T OPTION
	#365878	78T INCLUDED
	#365881	81T OPTION

OPTION #324103
SLIPPER ELIMINATOR - SET



Recommended for stock motor classes. Reduces rotating mass, reduces vehicle weight, and maximizes power throughput by eliminating the slipper clutch.

With the Slipper Eliminator, motor output & driveline impacts are transferred directly through the transmission gears, increasing the potential for transmission gear damage.

OPTION #325869
SLIPPER ELIMINATOR
SPUR GEAR 69T / 48



OPTION #324130-L
ALU 2-PAD SLIPPER CLUTCH PLATES
VENTILATED - SET

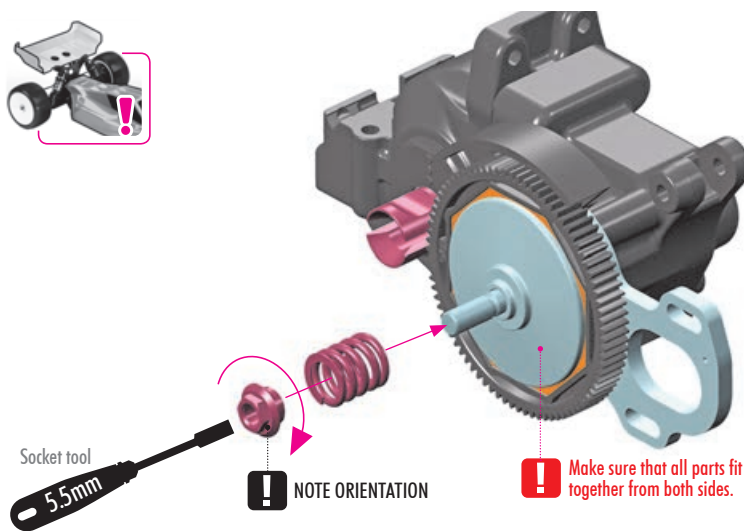

INITIAL SETTING
Flush with end
of shaft

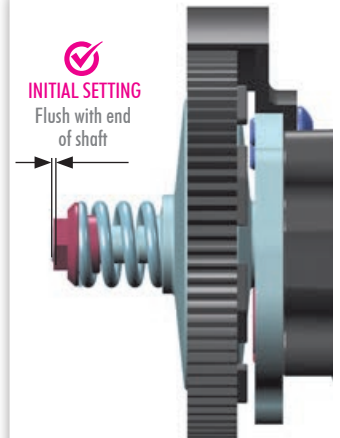

3. REAR SUSPENSION

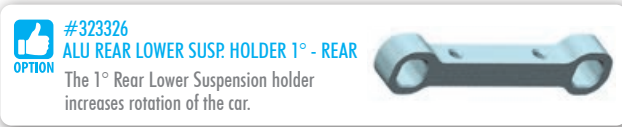
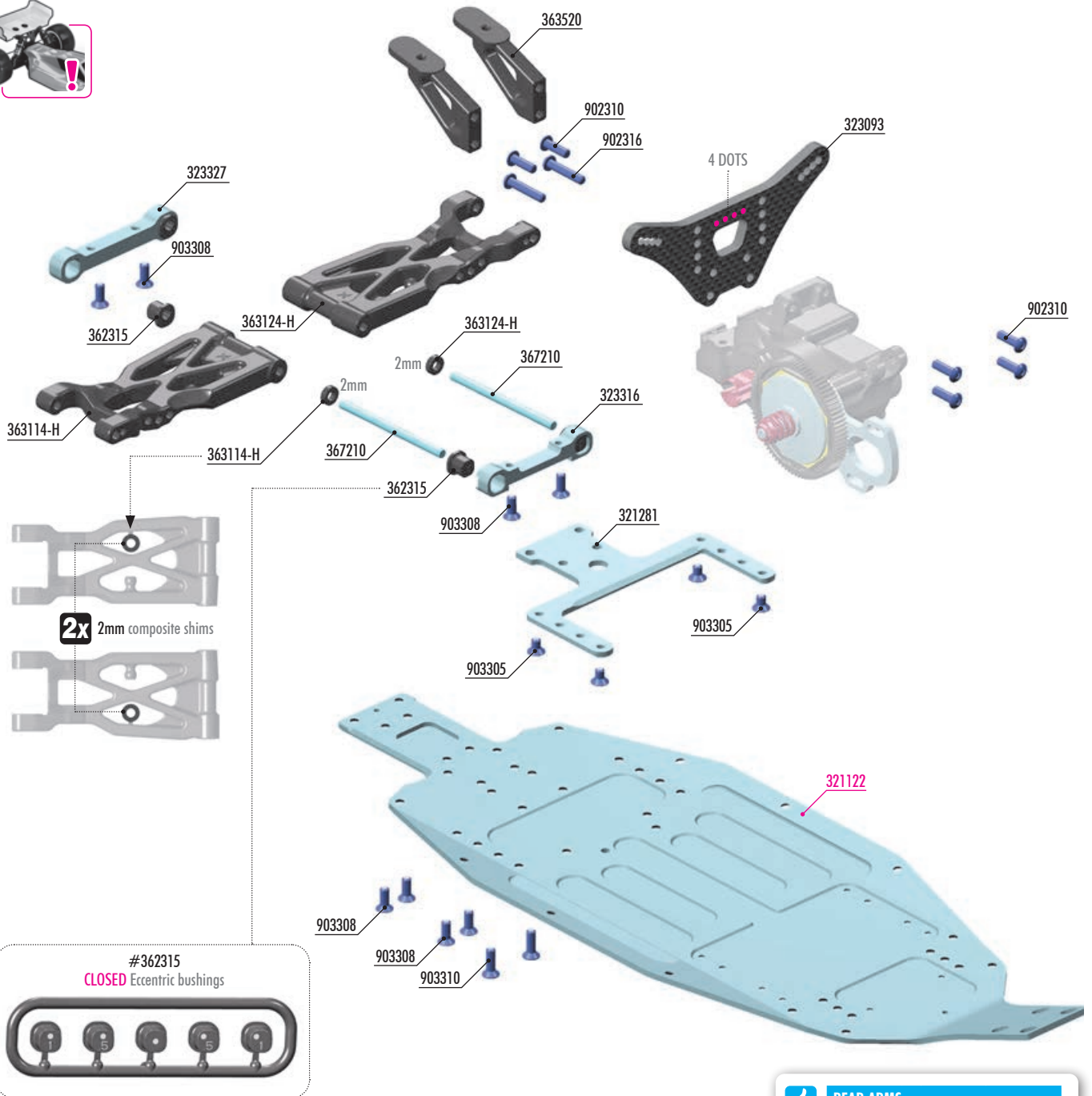

REAR ARMS			
#363114-M	R	MEDIUM	OPTION
#363124-M	L	MEDIUM	OPTION
#363114-H	R	HARD	INCLUDED
#363124-H	L	HARD	INCLUDED
#363114-G	R	GRAPHITE	OPTION
#363124-G	L	GRAPHITE	OPTION



- 321281 ALU CHASSIS BRACE FOR 3G GEAR BOX
- 323093 CARBON SHOCK TOWER - 4-DOTS - REAR
- 323316 ALU REAR LOWER SUSPENSION HOLDER FOR CHASSIS BRACE - FRONT
- 323327 ALU REAR LOWER SUSPENSION HOLDER 3° - WIDER - REAR
- 362315 CLOSED ECCENTRIC BUSHING SET (2)
- 363114-H COMPOSITE SUSPENSION ARM REAR LOWER RIGHT - HARD
- 363124-H COMPOSITE SUSPENSION ARM REAR LOWER LEFT - HARD
- 363520 REAR WING POST (2)
- 367210 REAR SUSPENSION PIVOT PIN (2)
- 902310 HEX SCREW SH M3x10 (10)
- 902316 HEX SCREW SH M3x16 (10)
- 903305 HEX SCREW SFH M3x5 (10)
- 903308 HEX SCREW SFH M3x8 (10)
- 903310 HEX SCREW SFH M3x10 (10)
- 321122 ALU CHASSIS - 2.0MM - MID-SIZE - REAR WIDE - SWISS 7075 T6

3. REAR SUSPENSION

- 2x From Rear Arm SHIM 3x6.5x2
- 4x 903305 SFH M3x5
- 4x 903308 SFH M3x8

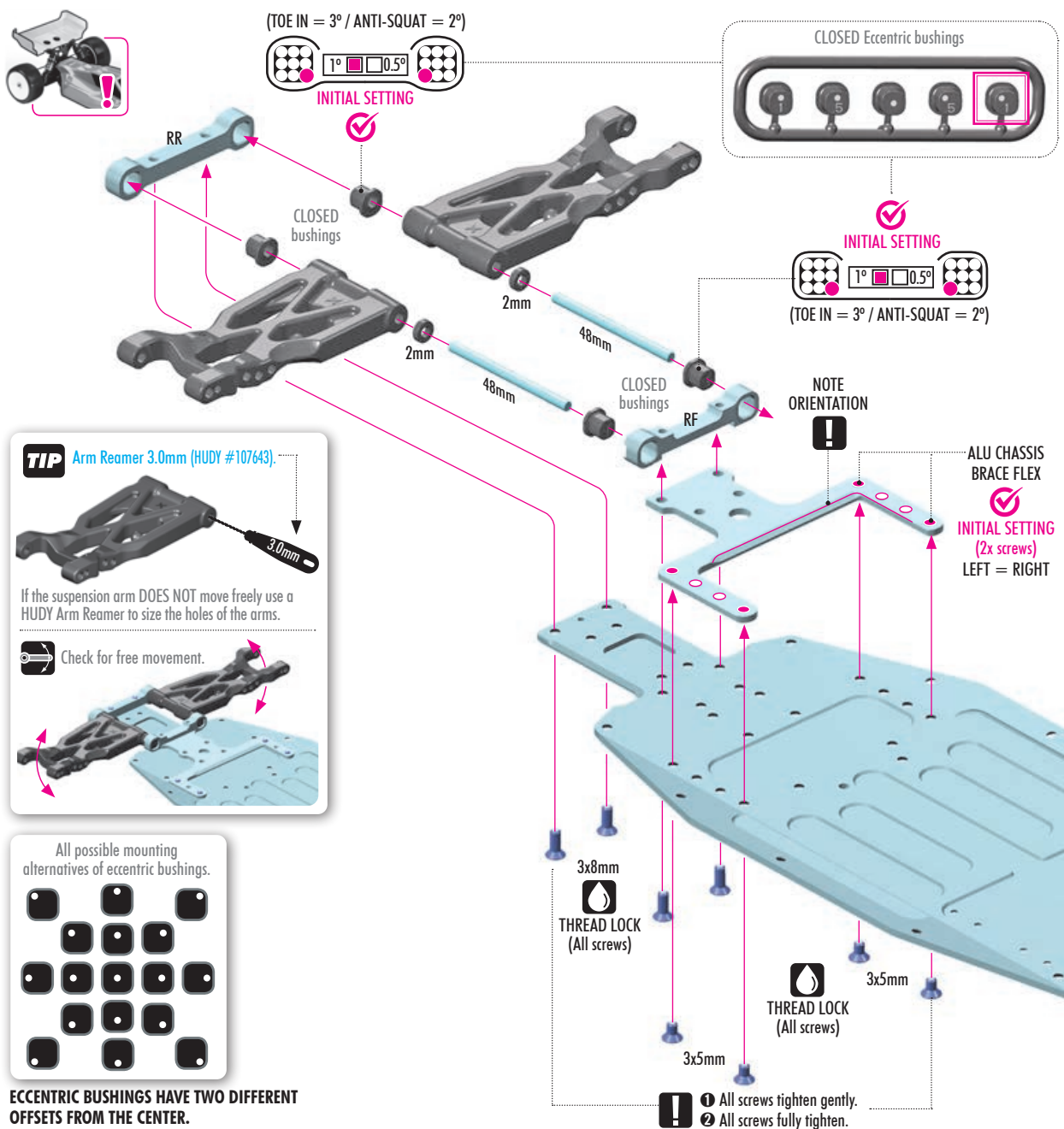

The XRAY rear alu lower suspension holders provide great range of adjustments for the rear suspension. Using different combinations of eccentric bushings, fine adjustment of rear anti-squat, rear toe-in, rear roll center, and rear track-width can be obtained. For more information about the influence of rear anti-squat, rear toe-in, rear roll center and rear track width on car handling, please refer to HUDY Set-up Book (#209100).

ANTI-SQUAT			(°)
RR	RF		
○	○	○	= 2.0°
○	○	○	= 3.0°
○	○	○	= 1.0°
○	○	○	= 3.0°
○	○	○	= 2.0°
○	○	○	= 4.0°
○	○	○	= 1.0°
○	○	○	= 2.0°
○	○	○	= 1.0°

ROLL CENTER			(mm)
RR	RF		
○	○	○	= +0.75mm
○	○	○	= 0mm
○	○	○	= -0.75mm

TRACK-WIDTH			(mm)
RR	RF		
○	○	○	= +1.5mm
○	○	○	= 0mm
○	○	○	= -1.5mm

TOE-IN			(°)
RR	RF		
○	○	○	= 3°
○	○	○	= 4°
○	○	○	= 2°
○	○	○	= 2°
○	○	○	= 3°
○	○	○	= 1°
○	○	○	= 4°
○	○	○	= 5°
○	○	○	= 3°

The tables describe the amounts of adjustment using the center and outside positions of the eccentric bushings. The middle position eccentric bushings allow for finer adjustment increments.

ANTI-SQUAT Example:

0(RR) - 0 (RF) = 2.0°	○	○	○	○	○	= 2.0°
0(RR) - 0.5 (RF) = 2.5°	○	○	○	○	○	= 2.5°
0(RR) - 1 (RF) = 3.0°	○	○	○	○	○	= 3.0°

The track-width is directly influenced by the size of the wheels and tires used.

3. REAR SUSPENSION



2x 902310
SH M3x10



2x 902316
SH M3x16

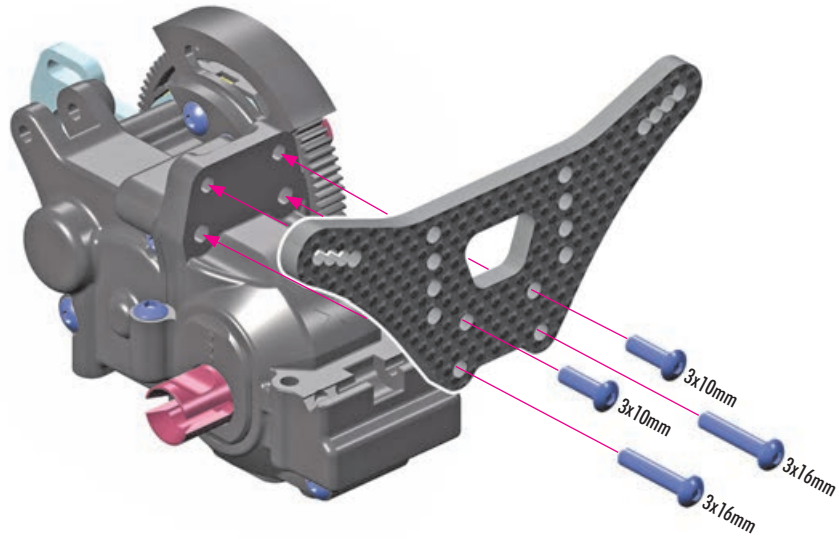

4x 902310
SH M3x10



4x 903308
SFH M3x8



2x 903310
SFH M3x10

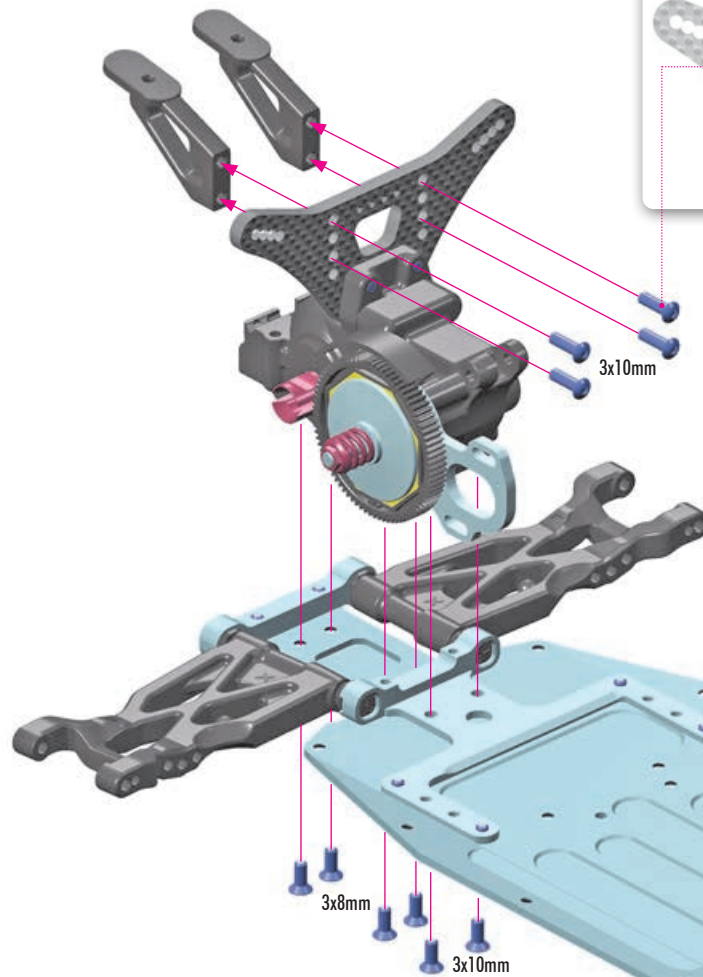
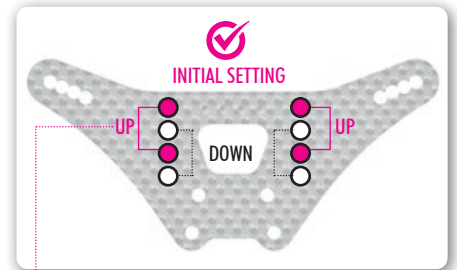

3. REAR DRIVETRAIN

!
Remaining ball joints will be used in the next sections of the instruction manual.

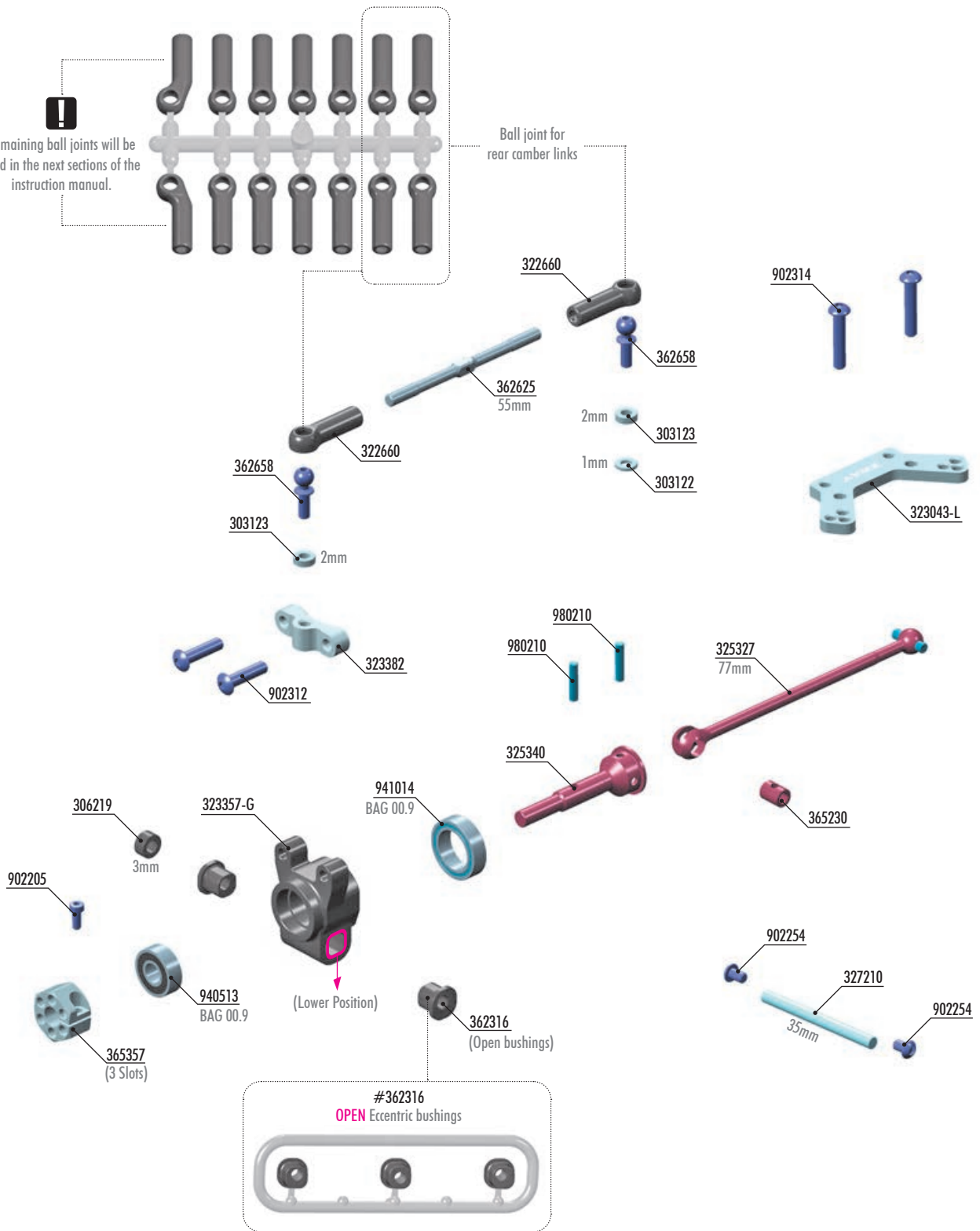

BAG

03

303122	ALU SHIM 3x6x1.0mm (10)	362658	HARD STEEL BALL END 5.4mm WITH 8mm THREAD - NICKEL COATED (2)
303123	ALU SHIM 3x6x2.0mm (10)	365230	DRIVE SHAFT COUPLING - HUDY SPRING STEEL™
306219	COMPOSITE SET OF SHIMS (4)	365357	ALU WHEEL HUB 12mm - 3 SLOTS - OFFSET "+ +2.25mm" (2)
322660	COMPOSITE BALL JOINT 5.4mm (12+1+1)		
323043-L	ALU REAR ROLL-CENTER HOLDER FOR ANTI-ROLL BAR COLLAR - 7075 T6	902205	HEX SCREW SH M2x5 (10)
323357-G	COMPOSITE UPRIGHT REAR - LOWER POSITION - GRAPHITE	902254	HEX SCREW SH M2.5x4 (10)
323382	ALU REAR HUB PLATE FOR MULTI ADJ. UPRIGHT - 1-HOLE - SWISS 7075 T6	902312	HEX SCREW SH M3x12 (10)
325327	REAR DRIVE SHAFT 77mm WITH 2.5mm PIN - HUDY SPRING STEEL™	902314	HEX SCREW SH M3x14 (10)
325340	REAR DRIVE AXLE LB - HUDY SPRING STEEL™	940513	BALL-BEARING 5x12x4 RUBBER SEALED - GREASE (2)
327210	SUSPENSION PIVOT PIN (2)	941014	BALL-BEARING 10x15x4 RUBBER SEALED - GREASE (2)
362316	OPEN ECCENTRIC BUSHING SET (2)	980210	PIN 2x9.8 (10)
362625	ADJUSTABLE TURNBUCKLE 55mm M3.5 L/R - HUDY SPRING STEEL™ (2)		

3. REAR DRIVETRAIN

2x 980210 P 2x10

2x LEFT = RIGHT
 1 2 3 SPECIFIC ORDER STEPS

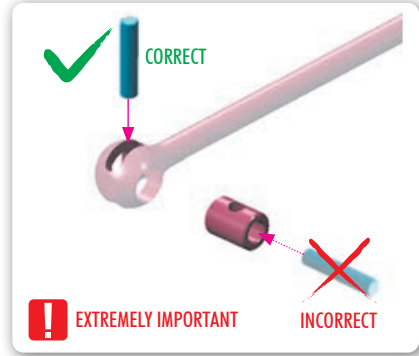
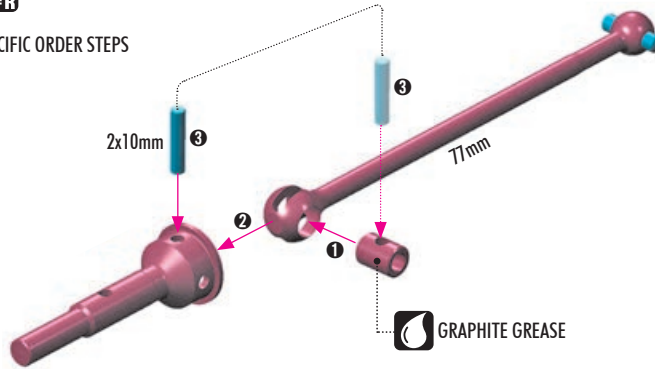

OPTION #305231 DRIVE SHAFT COUPLING HUDY SPRING STEEL

OPTION #325341 REAR ADJ. DRIVE AXLE LB - HUDY SPRING STEEL™
 #325390 ALU SHIM 10x12x2mm (2)

2x 902205 SH M2x5

2x 940513 BB 5x12x4

2x 941014 BB 10x15x4

2x 980210 P 2x10

2x LEFT = RIGHT
 1 2 3 SPECIFIC ORDER STEPS

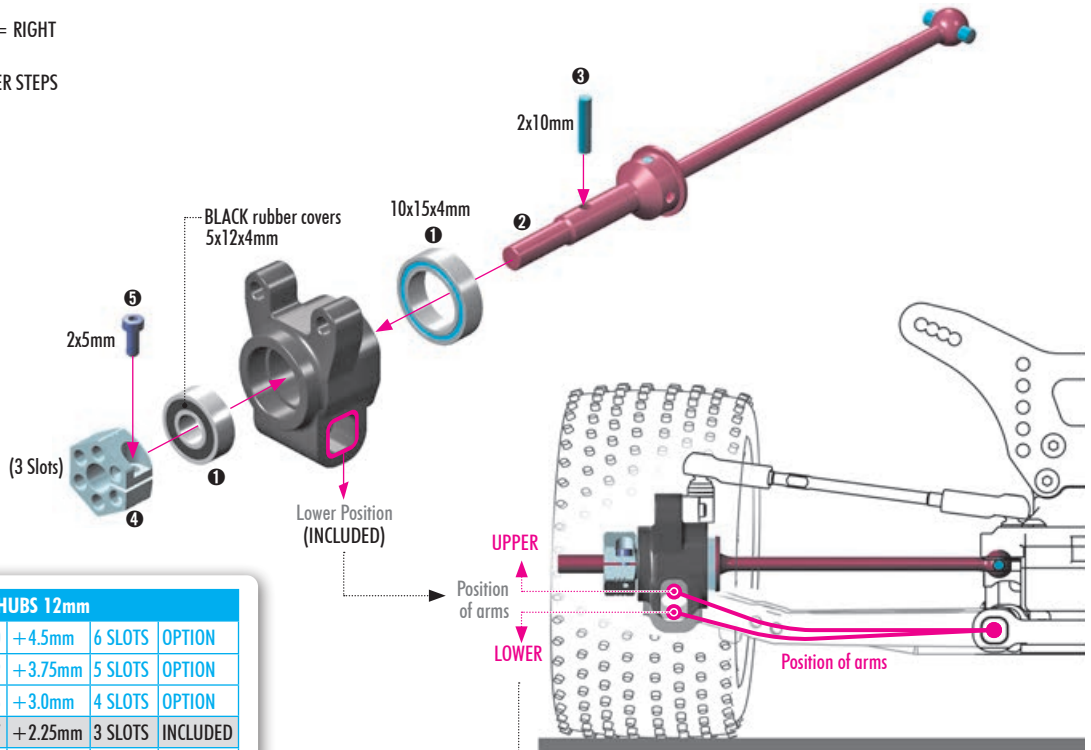

OPTION WHEEL HUBS 12mm

#365360	+4.5mm	6 SLOTS	OPTION
#365359	+3.75mm	5 SLOTS	OPTION
#365358	+3.0mm	4 SLOTS	OPTION
#365357	+2.25mm	3 SLOTS	INCLUDED
#365356	+1.5mm	2 SLOTS	OPTION
#365355	+0.75mm	1 SLOT	OPTION
#365353	0mm	0 SLOTS	OPTION
#365354	-0.75mm	Lightw.	OPTION
#365361	-1.25mm	Lightw.	OPTION

OPTIONAL HEX HUB EFFECTS

Different offset hex hubs are used to increase or decrease the track-width.

LESS OFFSET: Rear - more traction, Front - more steering
 MORE OFFSET: Rear - less traction, Front - less steering

OPTION XRAY BALL-BEARINGS

#940512	5x12x4	OIL	OPTION
#941015	10x15x4	OIL	OPTION
#940513	5x12x4	GREASE	INCLUDED
#941014	10x15x4	GREASE	INCLUDED

OPTION REAR UPRIGHTS

		Position	
#323354-M	MEDIUM	UPPER	OPTION
#323357-M	MEDIUM	LOWER	OPTION
#323354-H	HARD	UPPER	OPTION
#323354-G	GRAPHITE	UPPER	OPTION
#323357-G	GRAPHITE	LOWER	INCLUDED
#323355	ALU HIGH	UPPER	OPTION
#323356	ALU LOW	LOWER	OPTION

UPPER position

We recommend for these types of surfaces and traction:

- DIRT low & high traction
- Wet ASTRO

LOWER position

We recommend for these types of surfaces and traction:

- CARPET
- Dry ASTRO
- DIRT very high traction

3. REAR DRIVETRAIN

L=R LEFT = RIGHT

4x OPEN
Eccentric bushings

INITIAL SETTING ORIENTATION

2x

! **L=R**
Open bushings must have same orientation on each side.

L=R LEFT = RIGHT

INITIAL SETTING ORIENTATION

Alternative orientation

2x

3x12mm

L=R LEFT = RIGHT

2x 902314 SH M3x14

3x14mm

! **L=R**

REAR ROLL CENTER HOLDERS			
OPTION	#323044	HARD	OPTION
	#323044-G	GRAPHITE	OPTION
	#323043-L	ALU	INCLUDED

Check for free movement.

3. REAR DRIVETRAIN

- 

2x 306219 SHIM 3x6x3
- 

4x 902254 SH 2.5x4

2x  LEFT = RIGHT

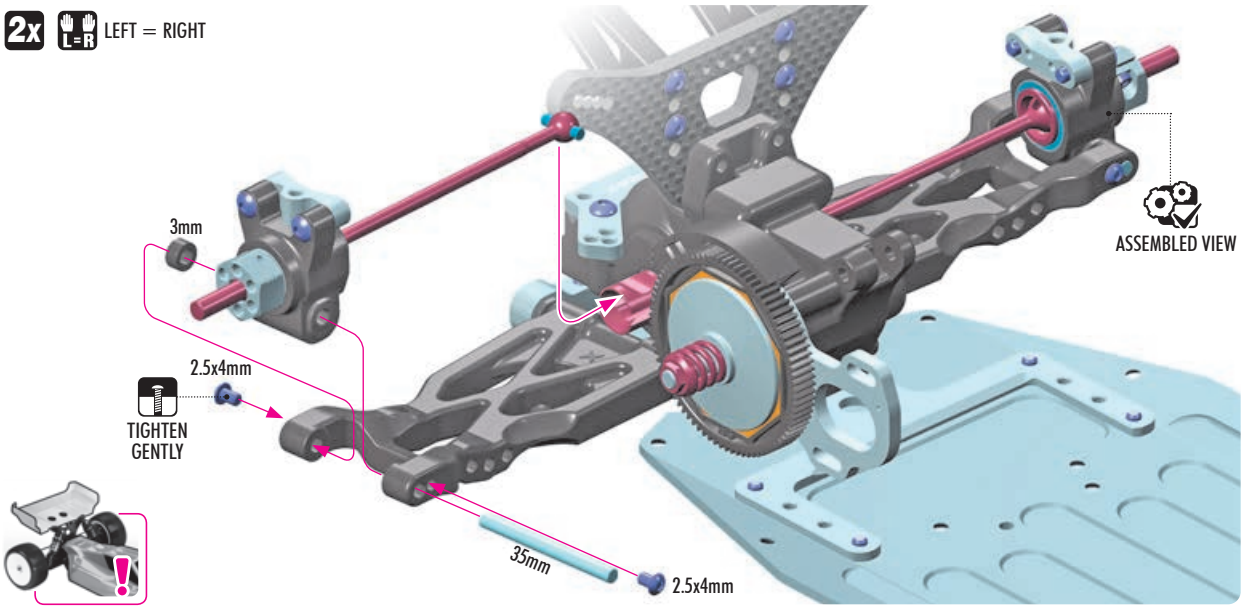

3mm

2.5x4mm

TIGHTEN GENTLY

35mm

2.5x4mm

ASSEMBLED VIEW

2x  LEFT = RIGHT

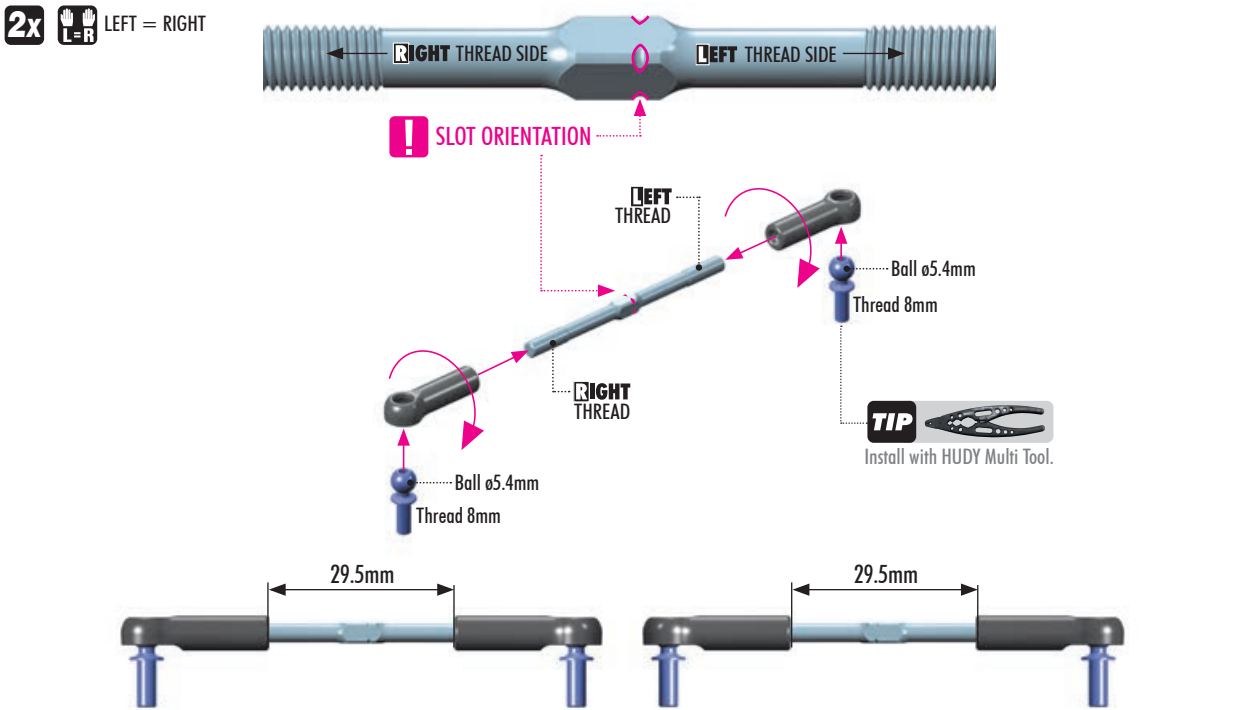

RIGHT THREAD SIDE

LEFT THREAD SIDE

! SLOT ORIENTATION

LEFT THREAD

RIGHT THREAD

Ball ø5.4mm

Thread 8mm

TIP  Install with HUDY Multi Tool.

Ball ø5.4mm

Thread 8mm

29.5mm

29.5mm

- 

2x 303122 SHIM 3x6x1
- 

4x 303123 SHIM 3x6x2

2x  LEFT = RIGHT

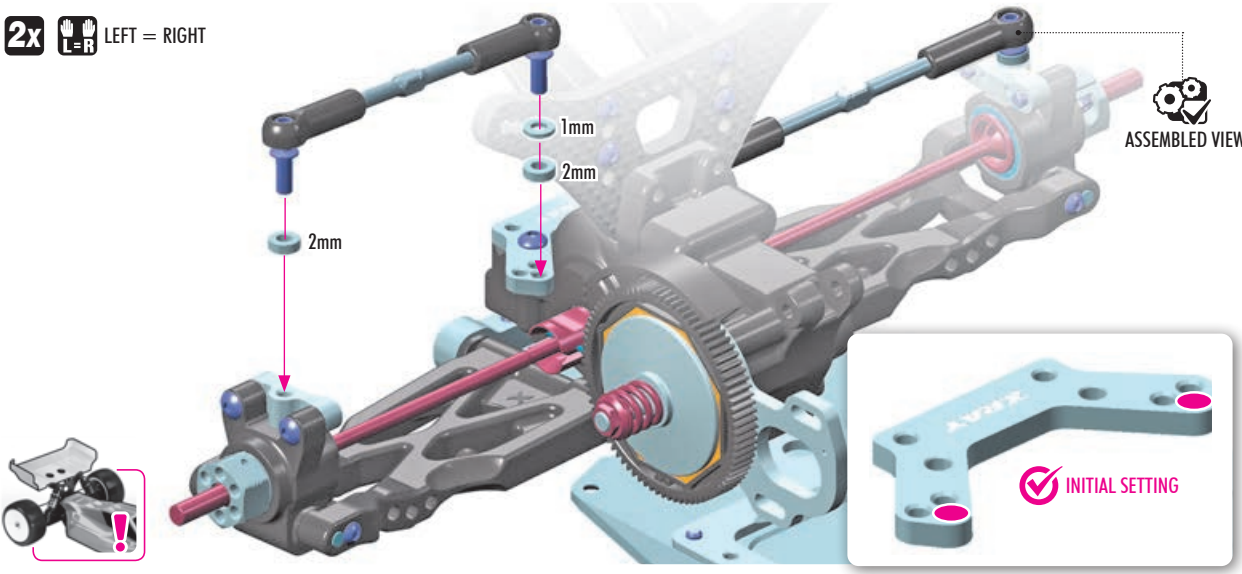

1mm

2mm

2mm

ASSEMBLED VIEW

INITIAL SETTING

4. FRONT ASSEMBLY



#322575
ALU STEERING PLATE FOR 1-PIECE CHASSIS - SET



#322516
ALU STEERING ARM FOR 1-PIECE CHASSIS - SWISS 7075 T6 (2)

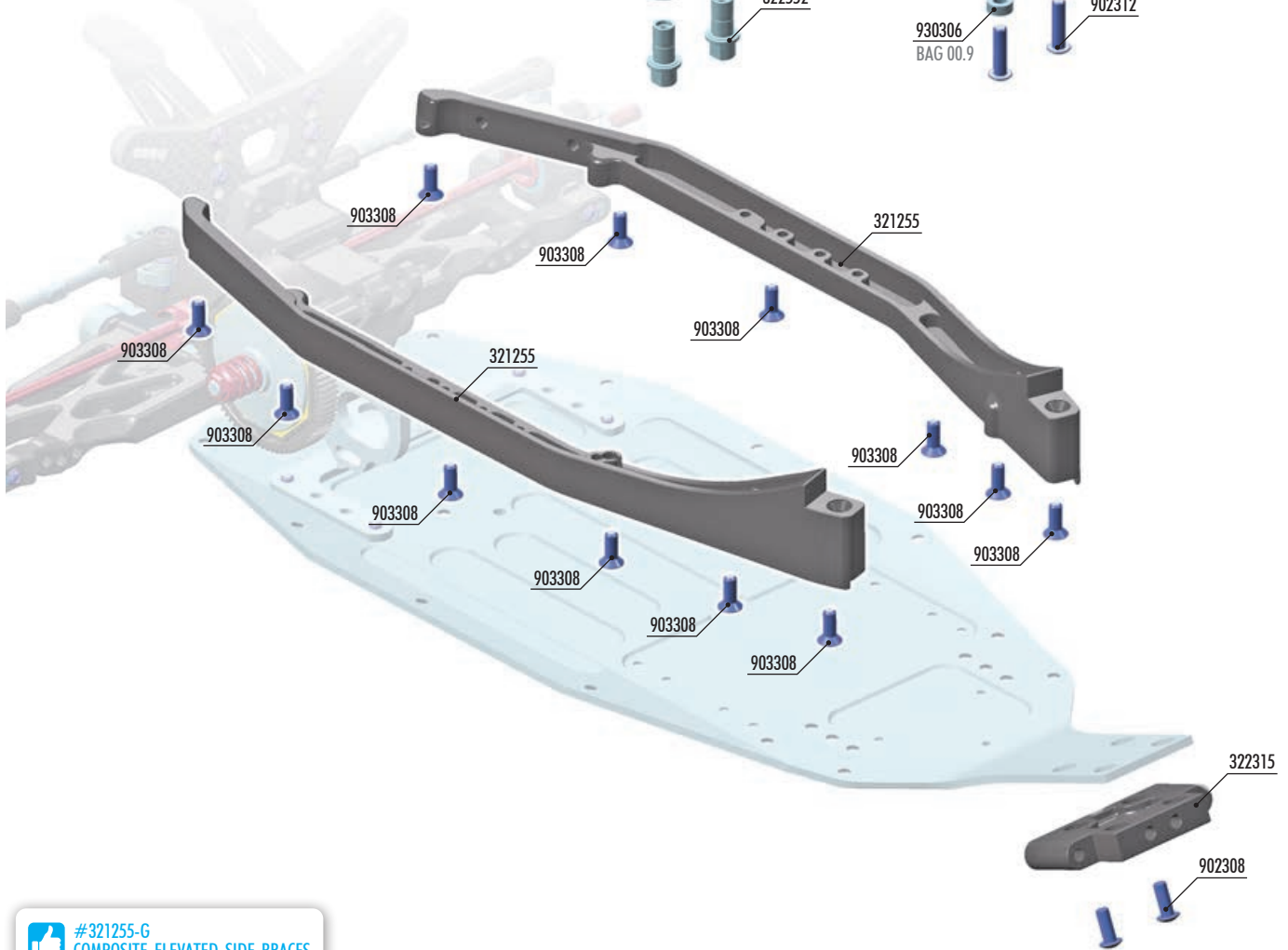
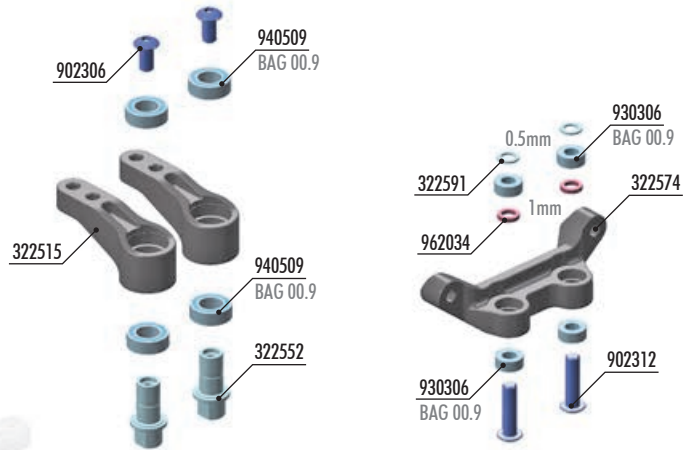

#32125-G
COMPOSITE ELEVATED SIDE BRACES L+R - LONG - GRAPHITE



BAG
04

32125 COMPOSITE ELEVATED SIDE BRACES L+R - LONG
322315 COMPOSITE FRONT LOWER ARM MOUNT FOR 1-PIECE CHASSIS
322515 COMPOSITE STEERING ARM FOR 1-PIECE CHASSIS (2)
322552 ALU STEERING PIVOT SHAFT 14.8mm - SWISS 7075 T6 (2)
322574 COMPOSITE STEERING PLATE FOR 1-PIECE CHASSIS
322591 ALU SHIM 3x4.7x0.5mm (10)

902306 HEX SCREW SH M3x6 (10)
902308 HEX SCREW SH M3x8 (10)
902312 HEX SCREW SH M3x12 (10)
903308 HEX SCREW SFH M3x8 (10)
930306 BALL-BEARING 3x6x2.5mm STEEL SEALED - OIL (2)
940509 BALL-BEARING 5x9x3mm RUBBER SEALED - OIL (2)
962034 STEEL WASHER S 3x4.7x1 (10)

4. FRONT ASSEMBLY

12x 903308
 SFH M3x8

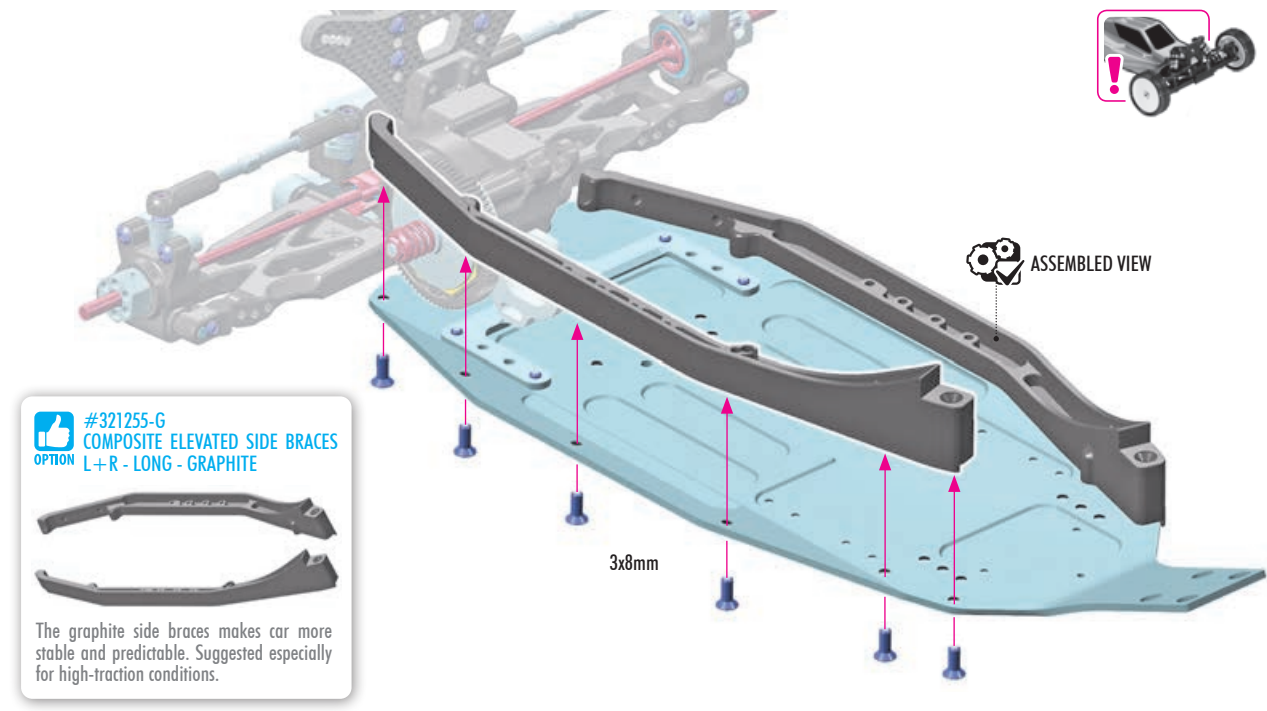

#321255-G
 COMPOSITE ELEVATED SIDE BRACES
 L+R - LONG - GRAPHITE

OPTION

The graphite side braces makes car more stable and predictable. Suggested especially for high-traction conditions.

3x8mm

ASSEMBLED VIEW

2x 962034
 S 3x4.7x1

4x 930306
 BB 3x6x2.5

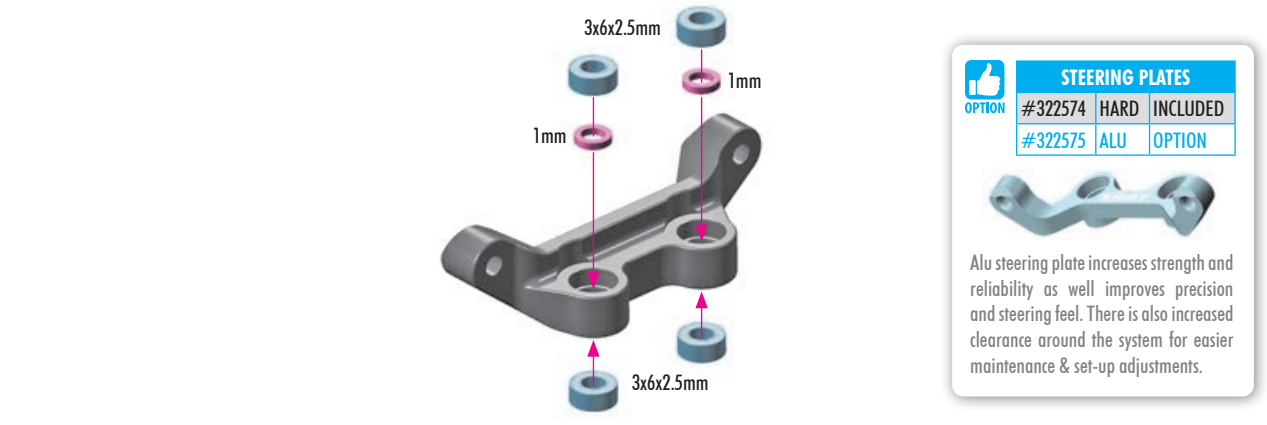

3x6x2.5mm

1mm

1mm

3x6x2.5mm

OPTION	#322574	HARD	INCLUDED
	#322575	ALU	OPTION

STEERING PLATES

Alu steering plate increases strength and reliability as well improves precision and steering feel. There is also increased clearance around the system for easier maintenance & set-up adjustments.

2x 322591
 SHIM 3x4.7x0.5

2x 902312
 SH M3x12

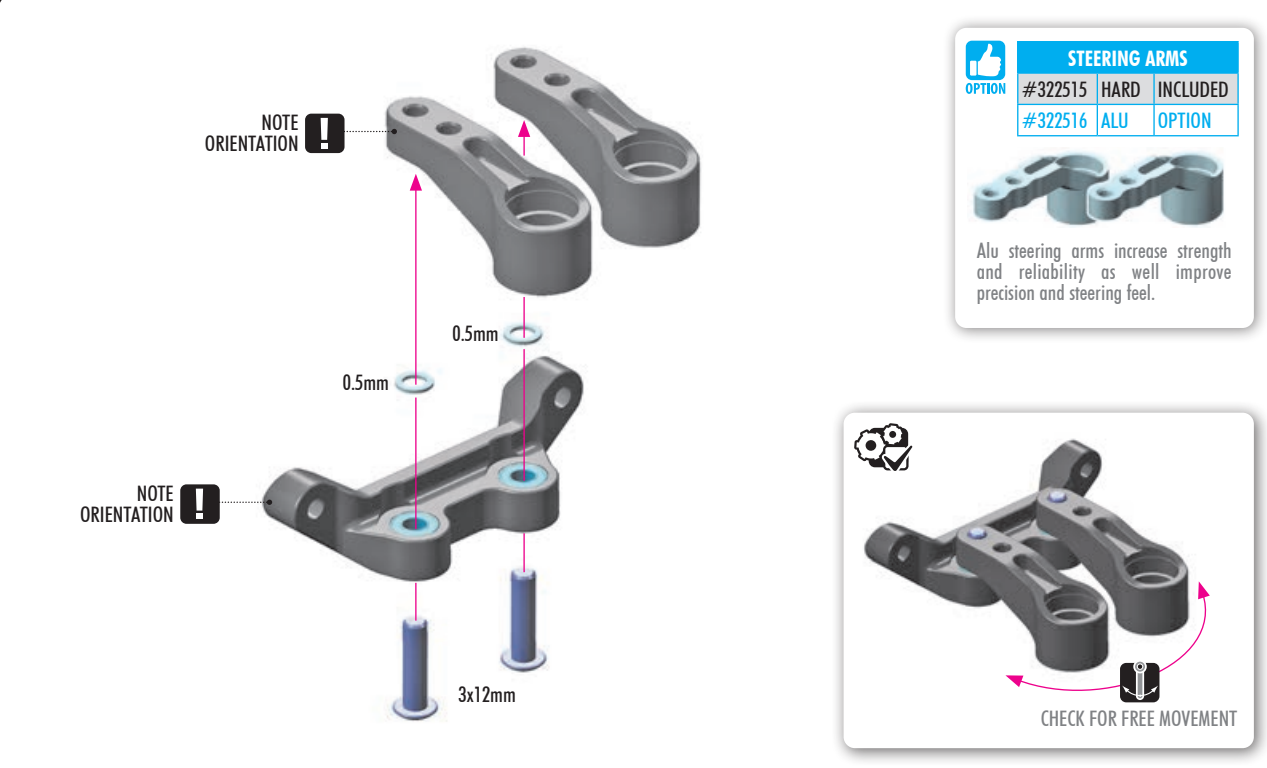

NOTE ORIENTATION

NOTE ORIENTATION

0.5mm

0.5mm

3x12mm

OPTION	#322515	HARD	INCLUDED
	#322516	ALU	OPTION

STEERING ARMS

Alu steering arms increase strength and reliability as well improve precision and steering feel.

CHECK FOR FREE MOVEMENT

4. FRONT ASSEMBLY

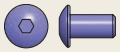

2x 902306
SH M3x6



4x 940509
BB 5x9x3

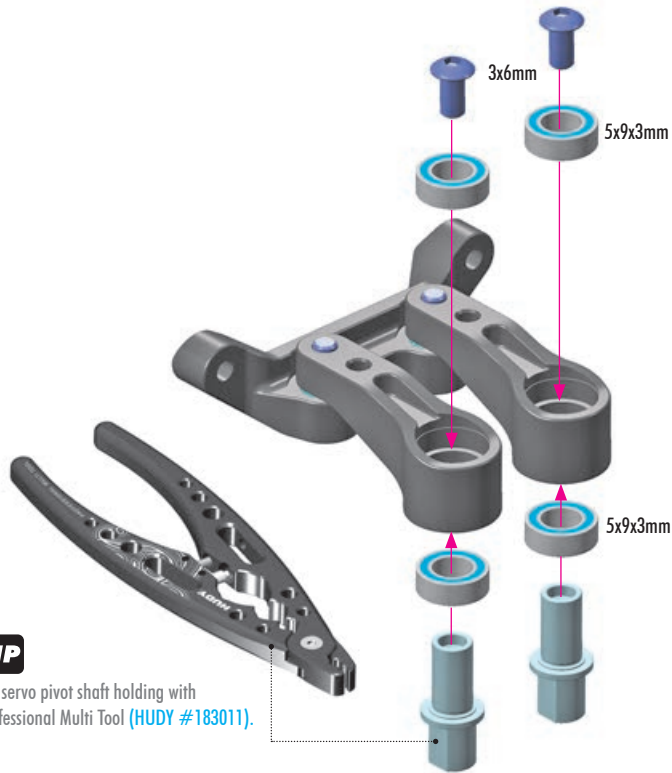

TIP

Alu servo pivot shaft holding with Professional Multi Tool (HUDY #183011).

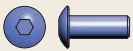

2x 902308
SH M3x8

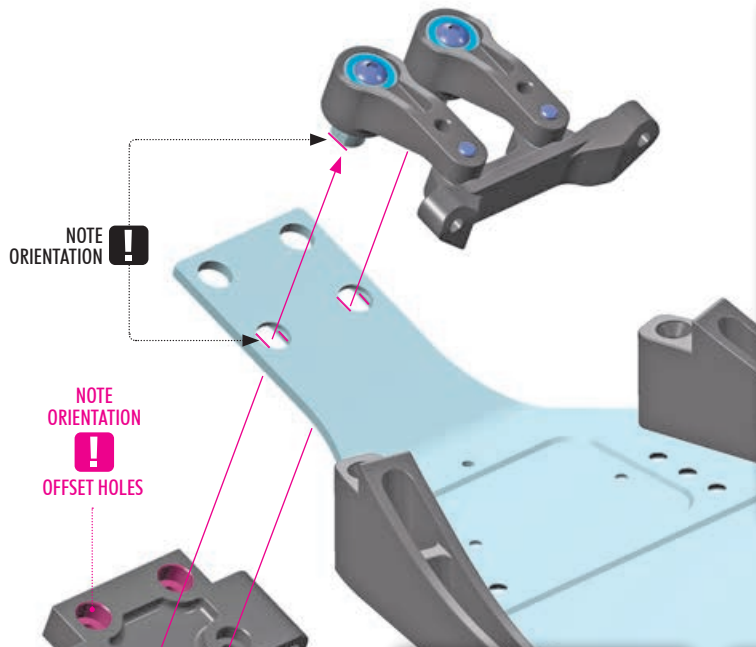

NOTE ORIENTATION

NOTE ORIENTATION
OFFSET HOLES

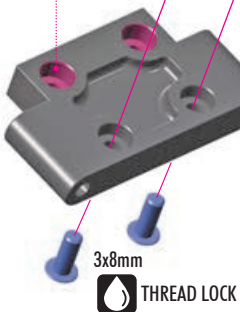

3x8mm
THREAD LOCK



The alu arm mounts can be used with optional weight:

OPTION #293085
HUDY Pure Tungsten Weight - 10g

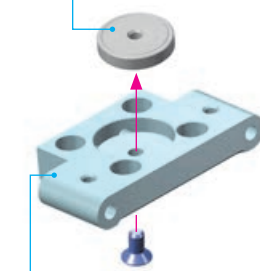

OPTION ALU FRONT LOWER ARM MOUNTS



FRONT LOWER ARM MOUNTS

#322316	ALU 0°	OPTION
#322315	COMPOSITE 0°	INCLUDED
#322312	BRASS 0°	OPTION
#322317	ALU +3°/-3°	OPTION
#321211	SUSP. HOLDER BRACE +3°/-3°	OPTION



ARM MOUNTS - WEIGHT			
Composite	BRASS	ALU	ALU + Tungsten
6g	46g	13.5g	23.5g

COMPOSITE - Generates more traction in front.

ALU - Makes car more stable.

BRASS - Adds more weight in front, less weight transfer.



ASSEMBLED VIEW

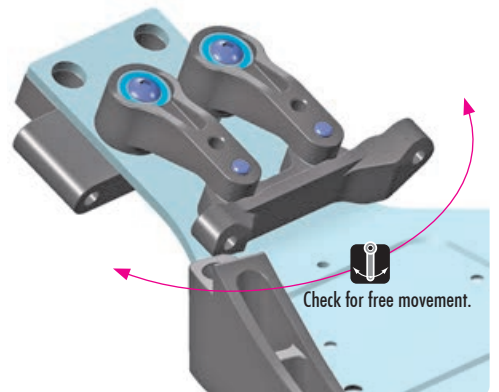

Check for free movement.

5. FRONT SUSPENSION

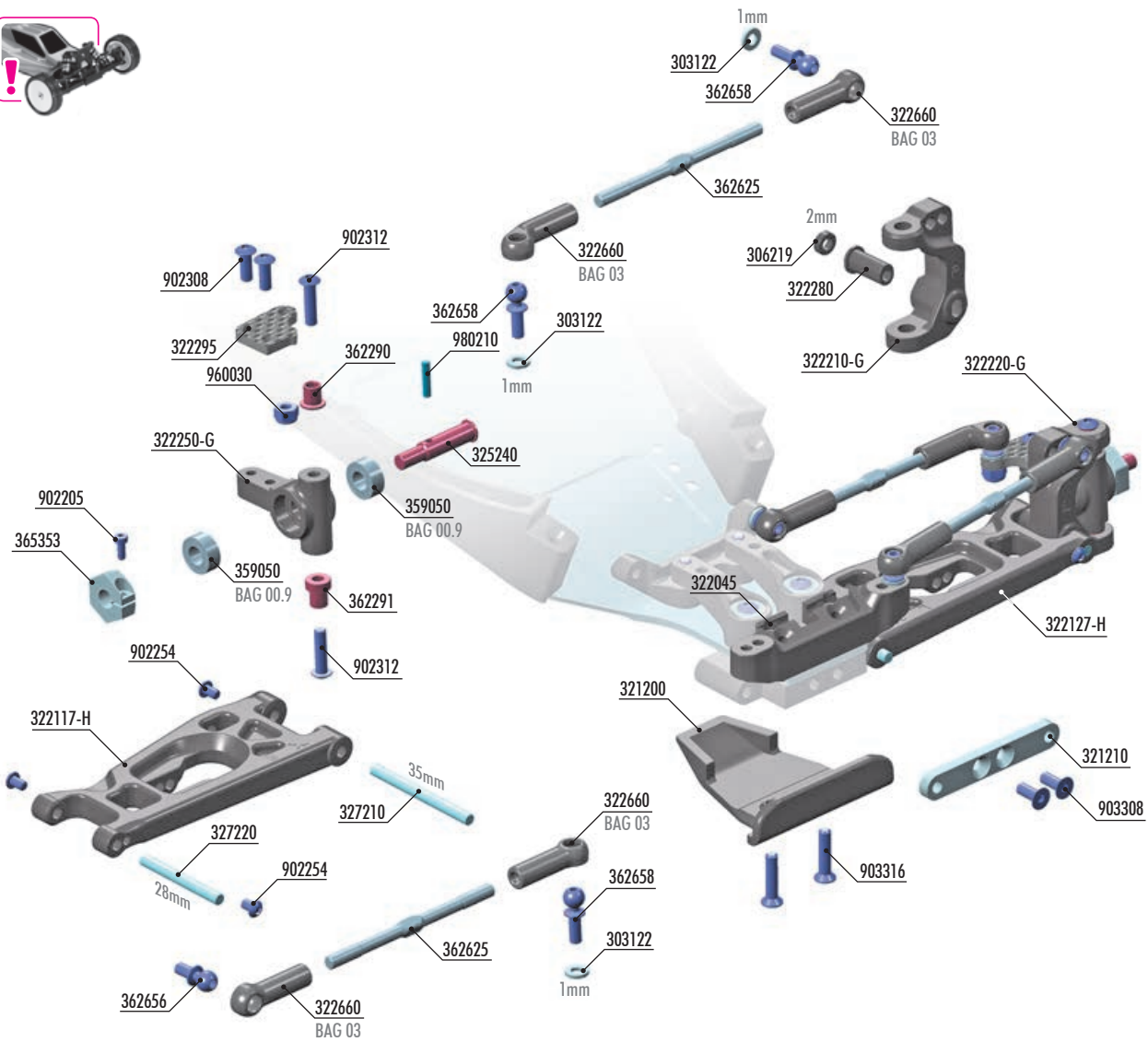

#320904
OPTION XB2 ALU STEERING BLOCKS & C-HUBS - SET
 For assembly instructions see page 46.

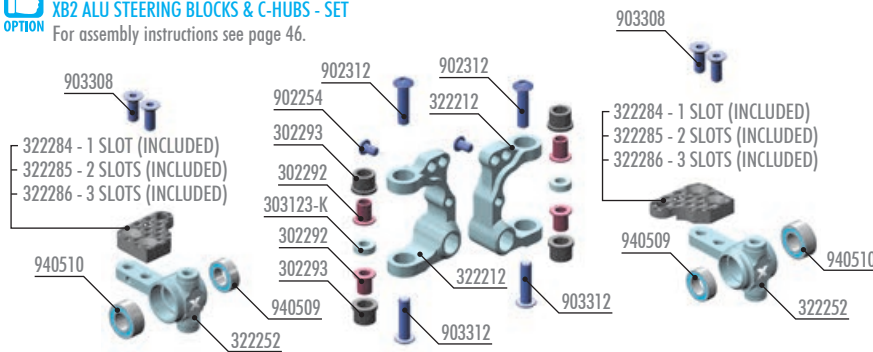

ASSEMBLED VIEW



303122	ALU SHIM 3x6x1.0mm (10)	362290	STEEL STEERING BUSHING - SHORT (2)
306219	COMPOSITE SET OF SERVO SHIMS (4)	362291	STEEL STEERING BUSHING - LONG (2)
321200	COMPOSITE FRONT BUMPER	362625	ADJUSTABLE TURNBUCKLE 55mm M3.5 L/R - HUDY SPRING STEEL™ (2)
321210	ALU SUSPENSION HOLDER BRACE - SWISS 7075 T6 (3mm)	362656	BALL ENDS 5.4mm WITH THREAD 6mm (2)
322045	COMPOSITE FRONT ROLL-CENTER HOLDER FOR BRIDGE UPPER DECK	362658	BALL ENDS 5.4mm WITH THREAD 8mm (2)
322117-H	SUSPENSION ARM FRONT - LSM - RIGHT - SHORT - HARD	365353	ALU WHEEL HUB 12mm - 0 SLOTS (2)
322127-H	SUSPENSION ARM FRONT - LSM - LEFT - SHORT - HARD		
322210-G	COMPOSITE C-HUB 0° DEG. RIGHT - GRAPHITE	359050	BALL-BEARING 5x10x4 STEEL SEALED - GREASE (2)
322220-G	COMPOSITE C-HUB 0° DEG. LEFT - GRAPHITE	902205	HEX SCREW SH M2x5 (10)
322250-G	COMPOSITE STEERING BLOCK - GRAPHITE	902254	HEX SCREW SH M2.5x4 (10)
322280	COMPOSITE CASTER ECCENTRIC BUSHING (2+2+2)	902308	HEX SCREW SH M3x8 (10)
322295	GRAPHITE EXTENSION FOR STEERING BLOCK - 2 DOTS (2)	902312	HEX SCREW SH M3x12 (10)
322660	COMPOSITE BALL JOINT 5.4mm (12+1+1)	903308	HEX SCREW SFH M3x8 (10)
325240	FRONT DRIVE AXLE - HUDY SPRING STEEL™	903316	HEX SCREW SFH M3x16 (10)
327210	FRONT SUSPENSION PIVOT PIN 3x35mm (2)	960030	NUT M3 (10)
327220	FRONT ARM PIVOT PIN 3x28mm (2)	980210	PIN 2x9.8 (10)

5. FRONT SUSPENSION



2x LEFT = RIGHT
1 **2** **3** SPECIFIC ORDER STEPS

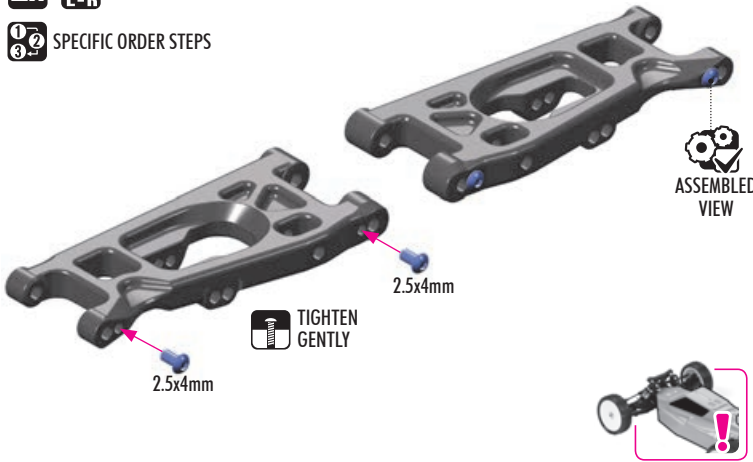

OPTION

FRONT LSM SUSPENSION ARMS - LONG			
#322113-M	RIGHT	MEDIUM	OPTION
#322123-M	LEFT	MEDIUM	OPTION
#322113-H	RIGHT	HARD	OPTION
#322123-H	LEFT	HARD	OPTION

OPTION

FRONT LSM SUSPENSION ARMS - SHORT			
#322117-M	RIGHT	MEDIUM	OPTION
#322127-M	LEFT	MEDIUM	OPTION
#322117-H	RIGHT	HARD	INCLUDED
#322127-H	LEFT	HARD	INCLUDED
#322117-G	RIGHT	GRAPHITE	OPTION
#322127-G	LEFT	GRAPHITE	OPTION



2x LEFT = RIGHT
1 **2** **3** SPECIFIC ORDER STEPS

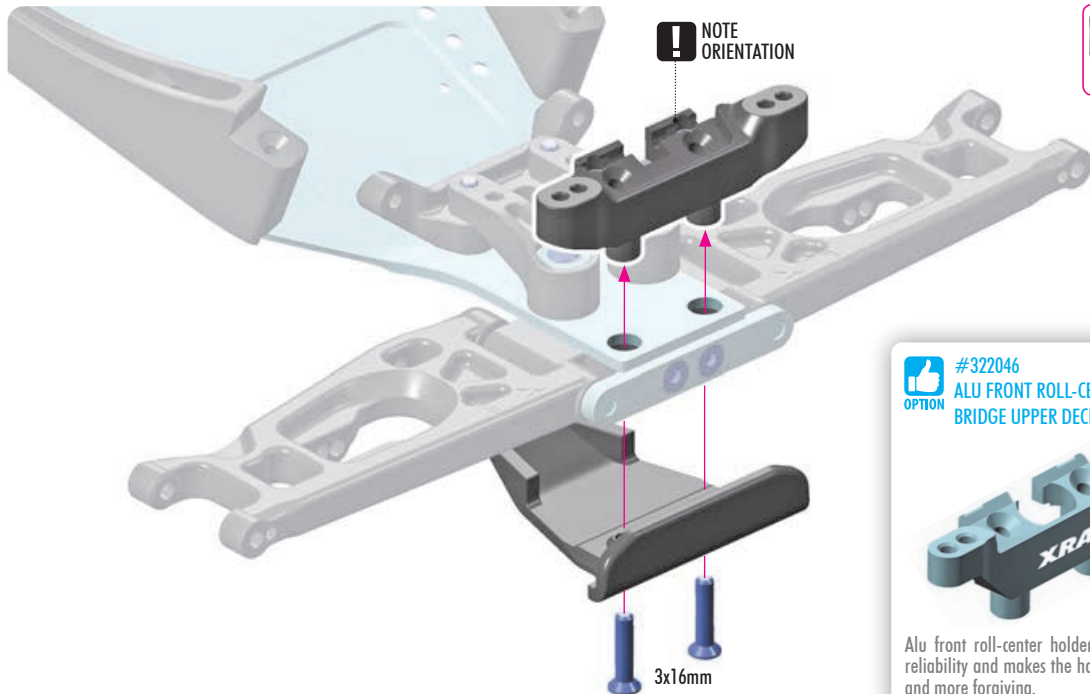
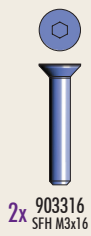
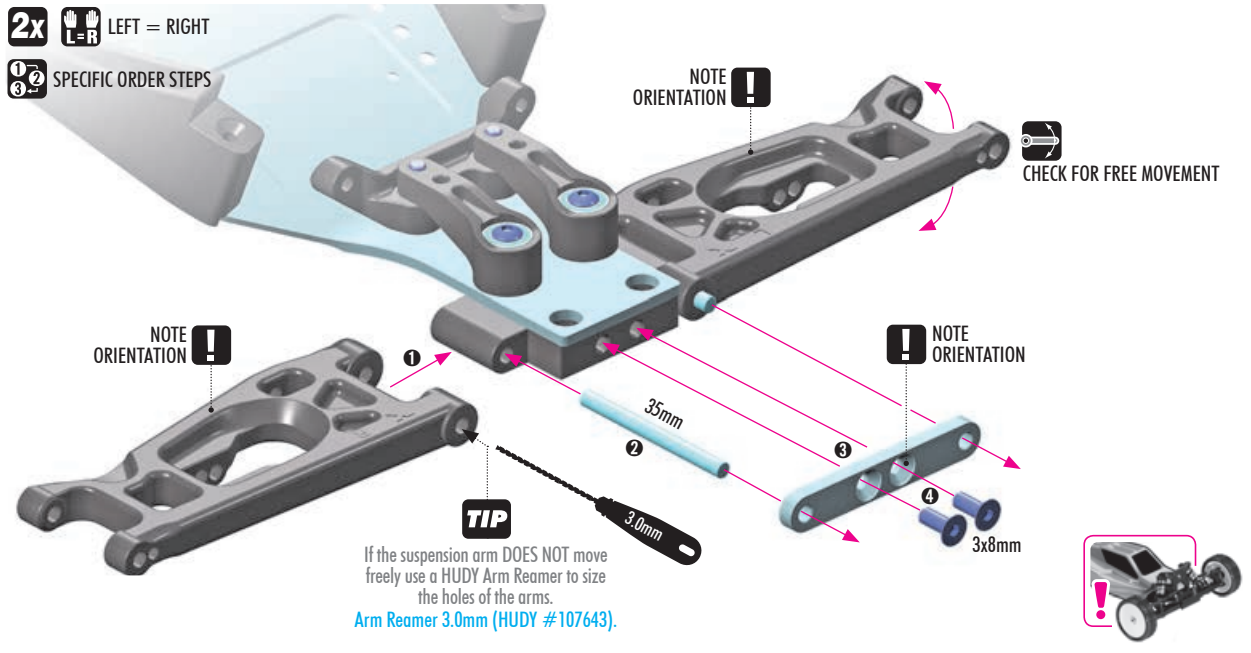

OPTION #322046
 ALU FRONT ROLL-CENTER HOLDER FOR BRIDGE UPPER DECK



Alu front roll-center holder increases strength, reliability and makes the handling more precise and more forgiving.

5. FRONT SUSPENSION

4x 902308 SH M3x8

4x 940510 BB 5x10x4

2x LEFT = RIGHT
 1 2 3 SPECIFIC ORDER STEPS

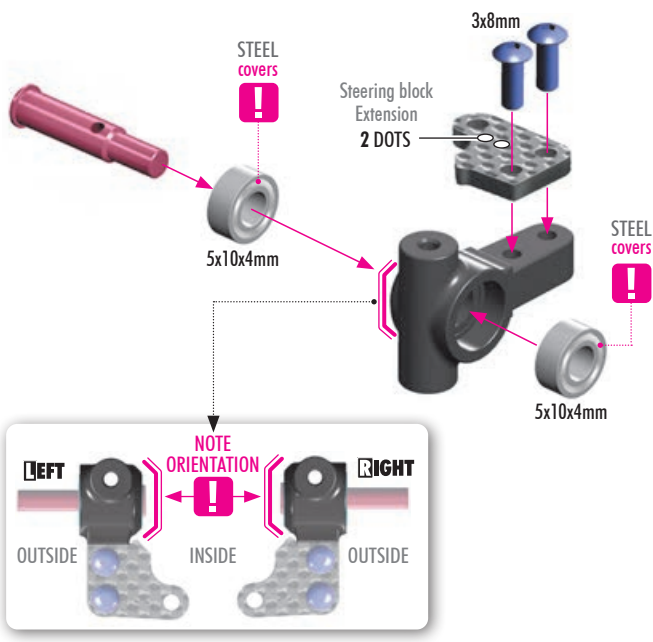

OPTION

STEERING BLOCK EXTENSIONS			
#322294	1 DOT	OPTION	
#322295	2 DOTS	INCLUDED	
#322296	3 DOTS	OPTION	

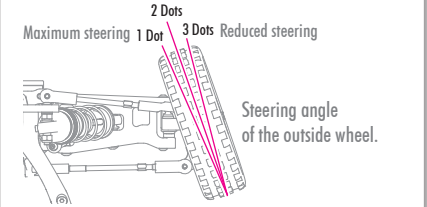

OPTION

STEERING BLOCKS		
#322250-M	MEDIUM	OPTION
#322250-H	HARD	OPTION
#322250-G	GRAPHITE	INCLUDED

MEDIUM - More steering on low traction.
 HARD - More free in corner on high traction.
 GRAPHITE - Less stopping in corner on high traction.

OPTION

XRAY BALL-BEARINGS			
#940510	5x10x4	OIL	OPTION
#359050	5x10x4	GREASE	INCLUDED

2x 902205 SH M2x5

2x 981210 P 2x10

2x LEFT = RIGHT
 1 2 3 SPECIFIC ORDER STEPS

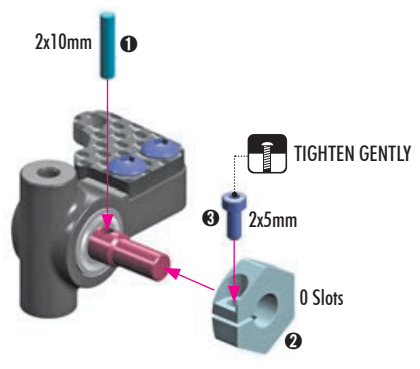

OPTION

WHEEL HEX HUBS 12MM			
#365360	+4.5mm	6 SLOTS	OPTION
#365359	+3.75mm	5 SLOTS	OPTION
#365358	+3.0mm	4 SLOTS	OPTION
#365357	+2.25mm	3 SLOTS	OPTION
#365356	+1.5mm	2 SLOTS	OPTION
#365355	+0.75mm	1 SLOT	OPTION
#365353	0mm	0 SLOTS	INCLUDED
#365354	-0.75mm	Lightw.	OPTION
#365361	-1.25mm	Lightw.	OPTION

4x 902312 SH M3x12

2x LEFT = RIGHT
 1 2 3 SPECIFIC ORDER STEPS

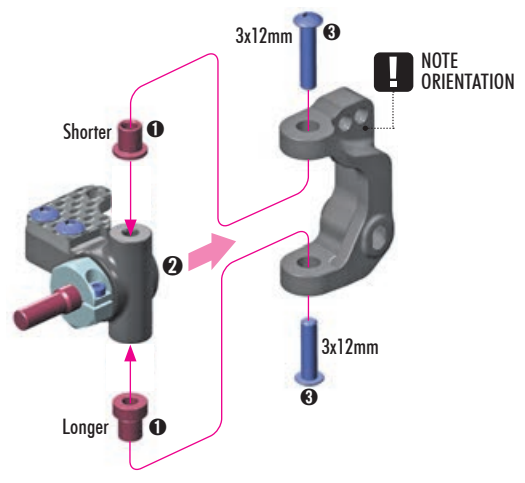

OPTION #320904 ALU STEERING BLOCKS & C-HUBS WITH BACKSTOP - SET

OPTION

C-HUBS			
#322210-M	RIGHT	MEDIUM	OPTION
#322210-H	RIGHT	HARD	OPTION
#322210-G	RIGHT	GRAPHITE	INCLUDED
#322220-M	LEFT	MEDIUM	OPTION
#322220-H	LEFT	HARD	OPTION
#322220-G	LEFT	GRAPHITE	INCLUDED

MEDIUM - For low traction. More steering on low traction.
 HARD - For medium traction. More steering, more free in corners.
 GRAPHITE - For high traction. More precise steering, less stopping in corners.



INITIAL SETTING
 TOP = SHORTER bushing
 BOTTOM = LONGER bushing
 Recommended for smooth tracks to gain more steering.

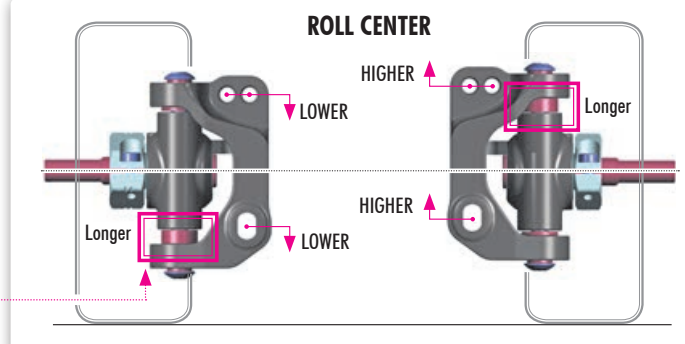

5. FRONT SUSPENSION

- IO**
- 2x 306219 SHIM 3x6x2
- 2x 902254 SH M2.5x4

INITIAL SETTING

2mm 2.5°

ASSEMBLED VIEW

28mm 2.5x4mm

Chassis KICK-UP 22° + Steering block CASTER 2.5° = Total CASTER 24.5°

CASTER ADJUSTMENT

LESS CASTER = increased steering off-power
 MORE CASTER = less steering off-power

CASTER ECCENTRIC BUSHINGS

0° 2.5° 5°

INITIAL SETTING

REAR FRONT

CUTAWAY VIEW

ROLL CENTER LINKS

2x LEFT = RIGHT

RIGHT THREAD SIDE LEFT THREAD SIDE

SLOT ORIENTATION

LEFT THREAD RIGHT THREAD

Ball ø5.4mm Thread 6mm Ball ø5.4mm Thread 8mm

TIP Install with HUDY Multi Tool.

26.4mm 26.4mm

5. FRONT SUSPENSION



2x 303122
 SHIM 3x6x1

ROLL CENTER LINKS

2x  LEFT = RIGHT

ASSEMBLED VIEW 

Thread 8mm
1mm
Thread 6mm

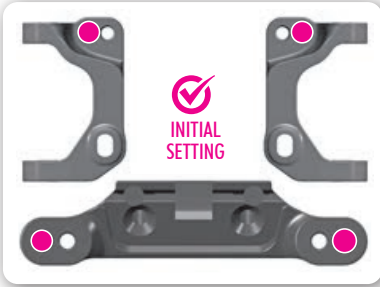

 INITIAL SETTING

STEERING LINKS

2x  LEFT = RIGHT

RIGHT THREAD SIDE LEFT THREAD SIDE

! SLOT ORIENTATION

Thread 8mm Ball ø5.4mm
LEFT THREAD

RIGHT THREAD

Ball ø5.4mm
Thread 8mm

TIP 
Install with HUDY Multi Tool.

approx. 27.4mm approx. 27.4mm

LEFT STEERING LINK RIGHT STEERING LINK



4x 303122
 SHIM 3x6x1

2x 960030
 NUT M3

STEERING LINKS

2x  LEFT = RIGHT

! NOTE ORIENTATION

ASSEMBLED VIEW 

1mm

! NOTE ORIENTATION

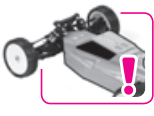

6. SHOCK ABSORBERS

FRONT SPRINGS				REAR SPRINGS			
	OPTION	#368381	L=42.5mm	1 DOTS	INCLUDED		OPTION
	OPTION	#368382	L=42.5mm	2 DOTS	OPTION		OPTION
	OPTION	#368382	L=42.5mm	2 DOTS	OPTION		OPTION
	OPTION	#368383	L=42.5mm	3 DOTS	OPTION		OPTION
	OPTION	#368384	L=42.5mm	4 DOTS	OPTION		OPTION
	OPTION	#368385	L=42.5mm	5 DOTS	OPTION		OPTION

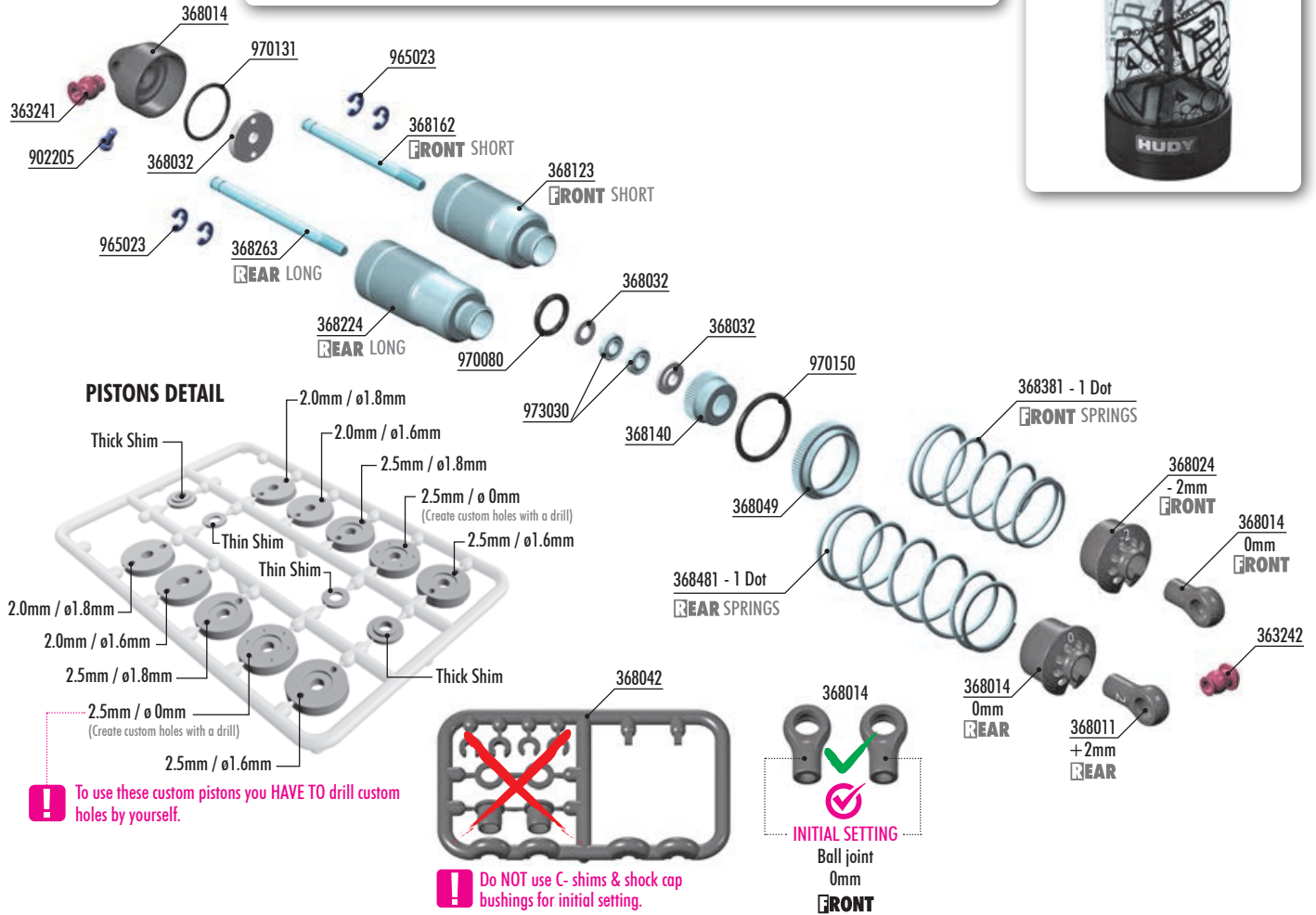

BAG 06			
363241	BALL UNIVERSAL 5.75mm WITH BACKSTOP (2)	368202	REAR SHOCK ABSORBERS 35.5mm - BIG BORE - SET (2)
363242	PIVOT BALL 5.8mm ECCENTRIC (2)	368224	ALU REAR SHOCK BODY 35.5mm - BIG BORE (2)
368014	COMP. SHOCK CAP, SPRING COLLAR & BALL JOINT - BIG BORE (2)	368263	REAR HARDENED SHOCK SHAFT 45mm (2)
368032	SHOCK PISTONS - COMPLETE SET - DELRIN - BIG BORE	902205	HEX SCREW SH M2x5 (10)
368042	COMPOSITE SHOCK BUSHING & SHIM (2+2)	965023	E-CLIP 2.3 (10)
368049	ALU SHOCK ADJUSTABLE NUT - BIG BORE (2)	970080	O-RING 8x1 (10)
368102	FRONT SHOCK ABSORBERS 30mm - BIG BORE - SET (2)	970131	O-RING 13 x 1.0 (10)
368123	ALU FRONT SHOCK BODY 30mm - BIG BORE (2)	970150	O-RING 15 x 1.5 (10)
368140	ALU LOWER SHOCK BODY CAP (2)	973030	SILICONE X-RING PRE-OILED 3x2 (8)
368162	FRONT HARDENED SHOCK SHAFT 40mm (2)		

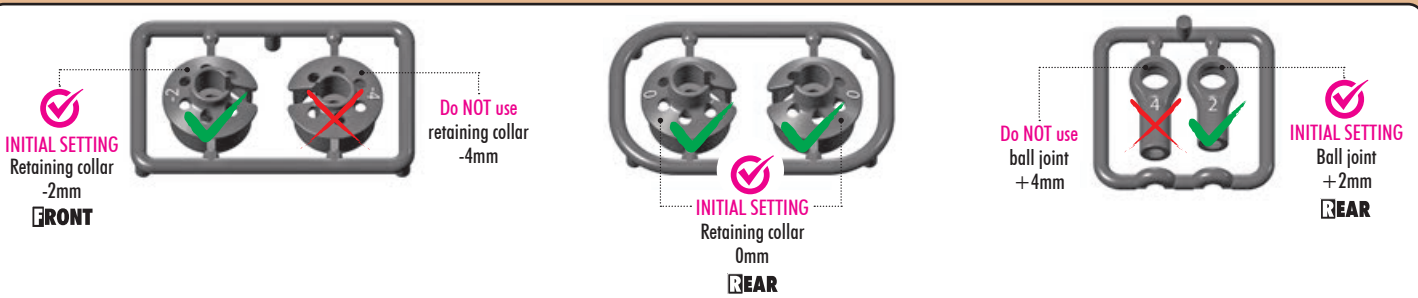

BAG 06.1			
368011	COMPOSITE SHOCK BALL JOINT +2mm & +4mm (2+2)	368381	FRONT CONICAL SPRING-SET L=42.5mm - 1 DOT (2)
368024	COMPOSITE SHOCK SPRING RETAINING COLLAR -2mm & -4mm (2+2)	368481	REAR CONICAL SPRING-SET L=57.5mm - 1 DOT (2)

6. SHOCK ABSORBERS

PISTONS ALTERNATIVE 1

We recommend for these types of surfaces and traction levels:

- ASTRO
- DIRT

INITIAL PISTON SETTING

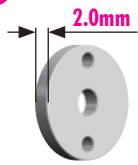

PISTONS ALTERNATIVE 2

We recommend for these types of surfaces and traction levels:

- CARPET

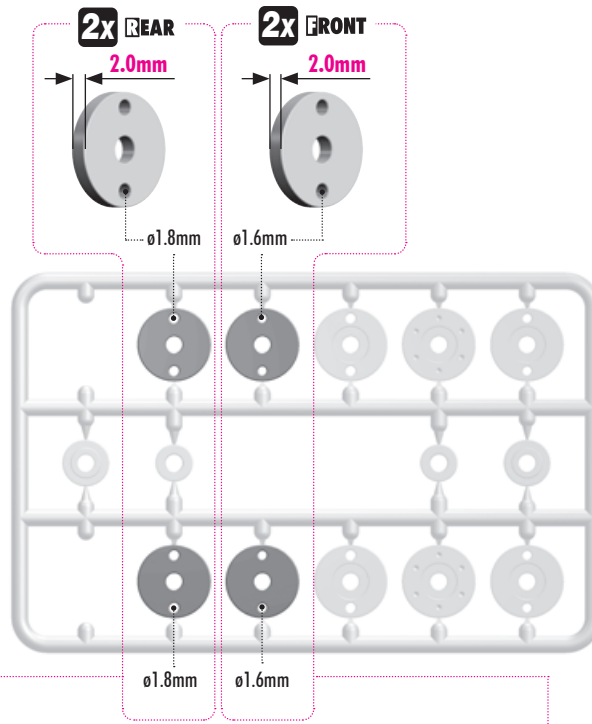
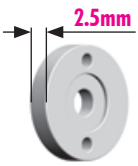

#368033
PRECISION GROUND SHOCK PISTON
BLANKS 2.5MM - BIG BORE (4)



#368034 PRECISION GROUND SHOCK
PISTON BLANKS 2.0MM - BIG BORE (4)



Big Bore piston blanks 2.0mm or 2.5mm thick for individual custom modification. All pistons are made from Delrin and are molded using ultra-high precision moulds and afterwards precisely ground for perfectly finished surface for smoother operation.

8x 965023
C 2.3

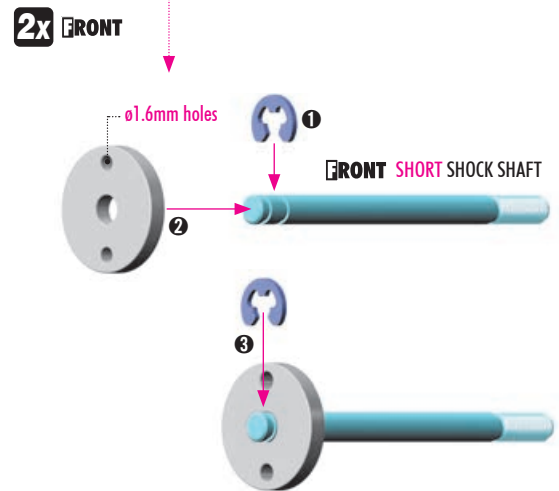
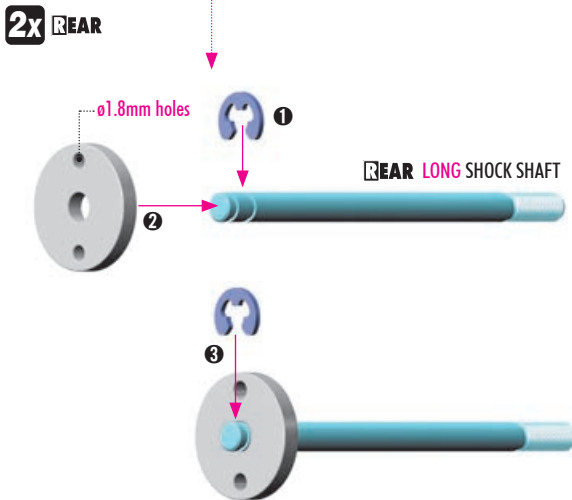

4x 970080
O 8x1

8x 973030
X 3x2

2x FRONT
2x REAR

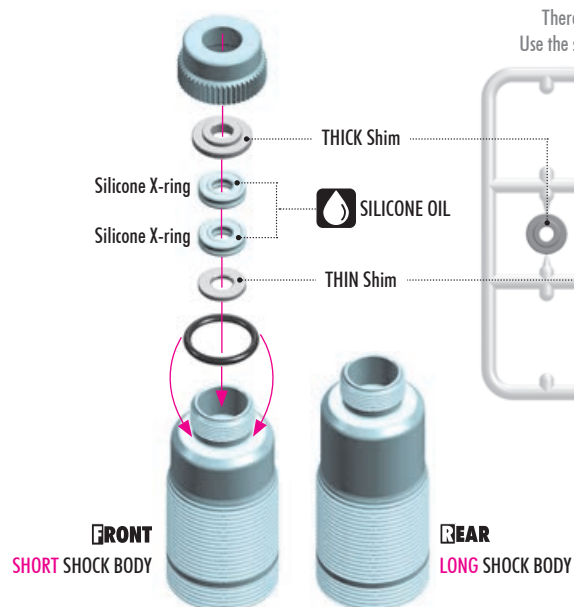

There are two different thickness shims, use them as shown. Use the same procedure when building both front and rear shocks.

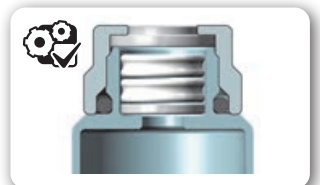
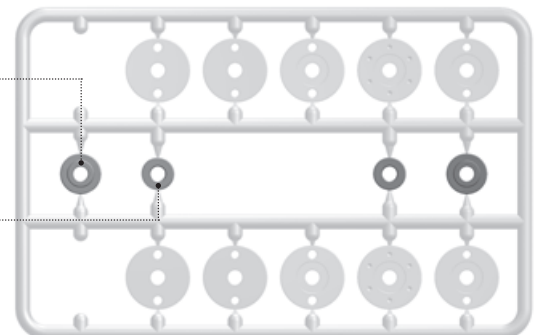

6. SHOCK ABSORBERS

2x FRONT **2x REAR**

EXTREMELY IMPORTANT

INCORRECT **CORRECT**

DO NOT PUSH the shock rod straight through the lower shock body assembly; X-ring damage may result.

4x 970150
O 15x1.5

4x

SILICONE OIL

Install the pivot balls with #183011 HUDY Multi Tool

REAR 2x +2mm

FRONT 2x 0mm

IMPORTANT ECCENTRIC PIVOT BALL IN LOWER Ball Joint

IMPORTANT There are two different pivot ball designs. Make sure to use the CORRECT one accordingly.

20mm FRONT

25mm REAR

Check that Front and Rear shock pairs are the same overall length.

4x 970131
O 13x1

4x

#368054
OPTION ALU SHOCK CAP-NUT - BIG BORE (2)

Alu upper shock cap ensure increased durability and extended life time. Machined from premium Swiss 7075 T6 aluminum and additionally black coated. The shock caps feature vent hole.

6. SHOCK ABSORBERS

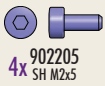

FRONT SHORT
Oil 300cSt

REAR LONG
Oil 300cSt

INITIAL SHOCK REBOUND SETTING 0% REBOUND INITIAL SETTING

Follow the steps below to set the shock rebound to the default setting of 0%.

- 1** Extend the shock shaft completely. Fill the shock body with the shock oil. For the **FRONT** shocks (short) use 300cSt oil. For the **REAR** shocks (long) use 300cSt oil.
- 2** Move the shock shaft up and down a few times to release the air bubbles trapped beneath the piston. 3~5x UP & DOWN
- 3** Orient the filled shock vertically for several minutes with the shock shaft fully extended. The remaining air bubbles will release.
- 4** TIGHTEN FULLY. Gently place the shock cap onto the filled shock body and start to tighten the cap. Tighten the cap fully.
- 5** Gently push the shock shaft completely into the shock body. Excess oil will flow through the hole in the shock cap.
- 6** Keep the shock shaft pushed in the shock body and insert the screw into the shock cap. Tighten gently. 2x5mm
- 7** 6x push the shaft up and down.
- 8** Untighten the screw.
- 9** Gently push the shock shaft completely into the shock body. Excess oil will flow through the hole in the shock cap.
- 10** Tighten the screw. The rebound will be at approx. 0%.

2x FRONT
2x REAR

NOTE ORIENTATION OF SPRINGS

WIDE SIDE on TOP

NARROW SIDE on BOTTOM

FRONT SHORT 0mm

FRONT SHORT Springs 1 Dot

FRONT Retaining collar -2mm

REAR LONG +2mm

REAR LONG Springs 1 Dot

REAR Retaining collar 0mm

#368021 ALU SHOCK SPRING RET. COLLAR (4) **OPTION**

#368022 ALU SHOCK SPRING RET. COLLAR -2mm (4) **OPTION**

#368023 ALU SHOCK SPRING RET. COLLAR -4mm (4) **OPTION**

Set of lower aluminum shock collars for increased reliability. Stylish and lightweight collars are CNC-machined from premium Swiss 7075 T6 aluminum and are strategically lightened. Set of four. Black color.

7. FINAL ASSEMBLY

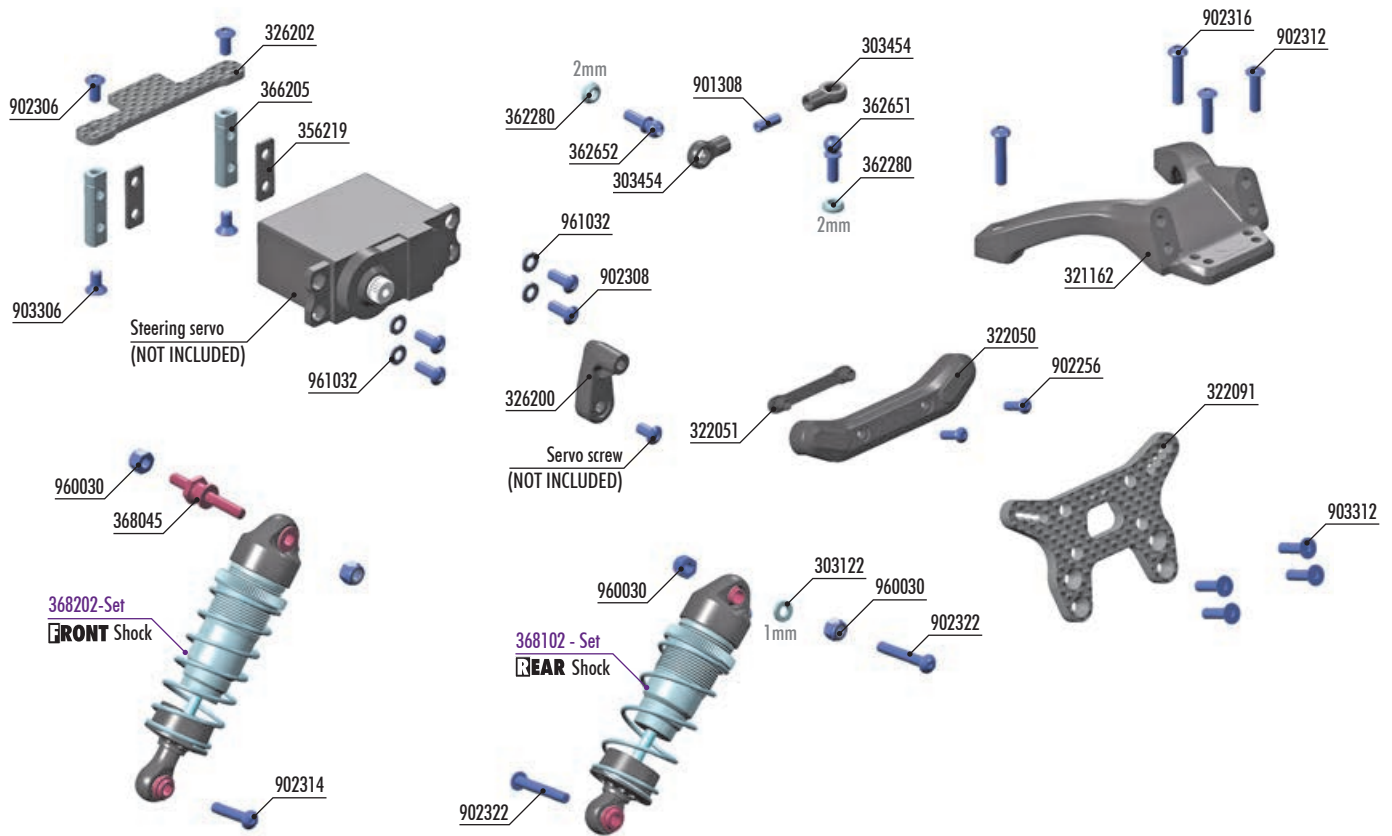

#293421
 ALU CLAMP STEER. SERVO HORN
 EXTENDED 8mm - 23T

#293422
 ALU CLAMP STEER. SERVO HORN
 EXTENDED 8mm - 25T



303122	ALU SHIM 3x6x1.0mm (10)	901308	HEX SCREW SB M3x8 (10)
303454	BALL JOINT 4.9mm - OPEN (4)	902256	HEX SCREW SH M2.5x6 (10)
321162	COMP. FRONT BRIDGE UPPER DECK	902306	HEX SCREW SH M3x6 (10)
322050	COMP. FRONT SHOCK TOWER PROTECTOR	902308	HEX SCREW SH M3x8 (10)
322051	COMP. FRONT SHOCK TOWER INSERT (2)	902312	HEX SCREW SH M3x12 (10)
322091	CARBON SHOCK TOWER FOR BRIDGE UPPER DECK - 2-DOTS - FRONT	902314	HEX SCREW SH M3x14 (10)
326200	COMP. STEERING SERVO ARMS - EXT. - 23T+25T	902316	HEX SCREW SH M3x16 (10)
326202	ALU SERVO HOLDERS & CARBON BRIDGE	902322	HEX SCREW SH M3x22 (10)
356219	COMP. SERVO SHIMS 1.0, 1.5 & 2.5mm (2+2+2)	903306	HEX SCREW SFH M3x6 (10)
362280	ALU CONICAL SHIM 3x6x2.0mm (10)	903312	HEX SCREW SFH M3x12 (10)
362651	BALL END 4.9mm WITH THREAD 8mm (2)	960030	NUT M3 (10)
362652	BALL END 4.9mm WITH THREAD 10mm (2)	961032	WASHER S 3.2 (10)
366205	ALU SERVO MOUNT 22mm	368102	FRONT SHOCK ABSORBERS 30mm - BIG BORE - SET (2)
368045	STEEL SCREW SHOCK PIVOT BALL (2)	368202	REAR SHOCK ABSORBERS 35.5mm - BIG BORE - SET (2)

7. FINAL ASSEMBLY

1x 901308
SB M3x8

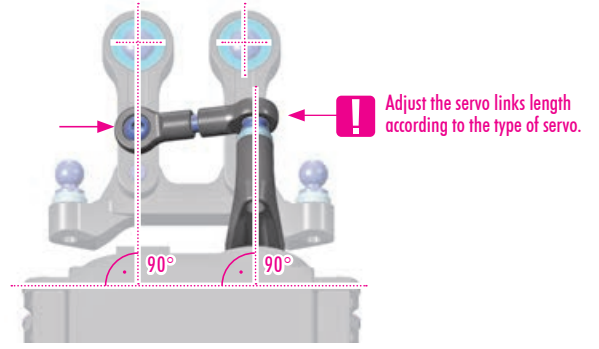
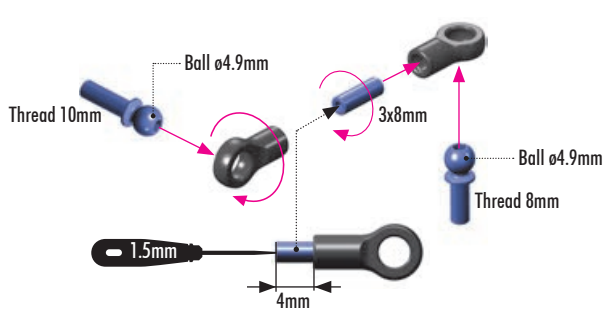

2x 902306
SH M3x6

4x 902308
SH M3x8

4x 961032
SHIM S 3.2

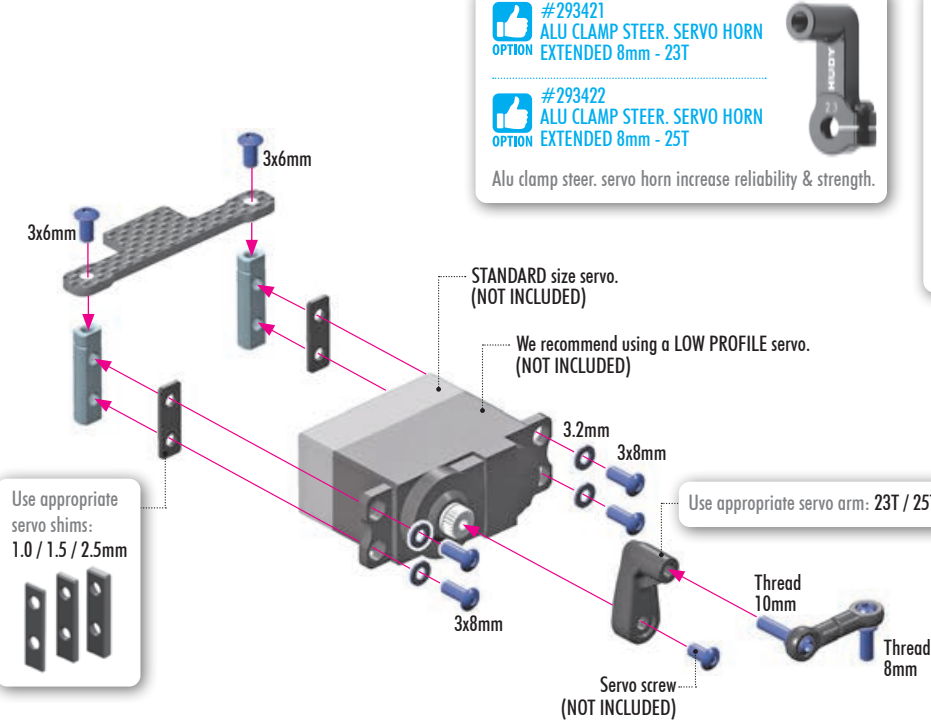

1x 362280
CON. SHIM 3x6x2

2x 903306
SFH M3x6

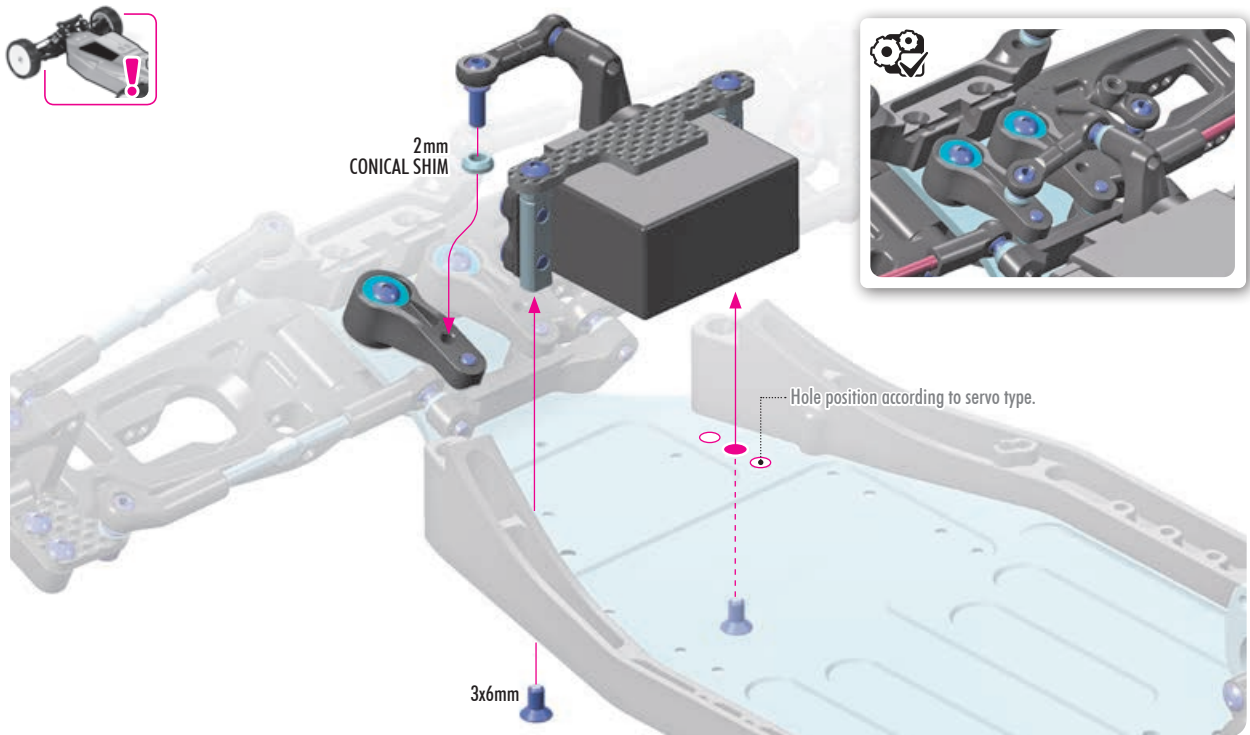

7. FINAL ASSEMBLY

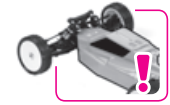
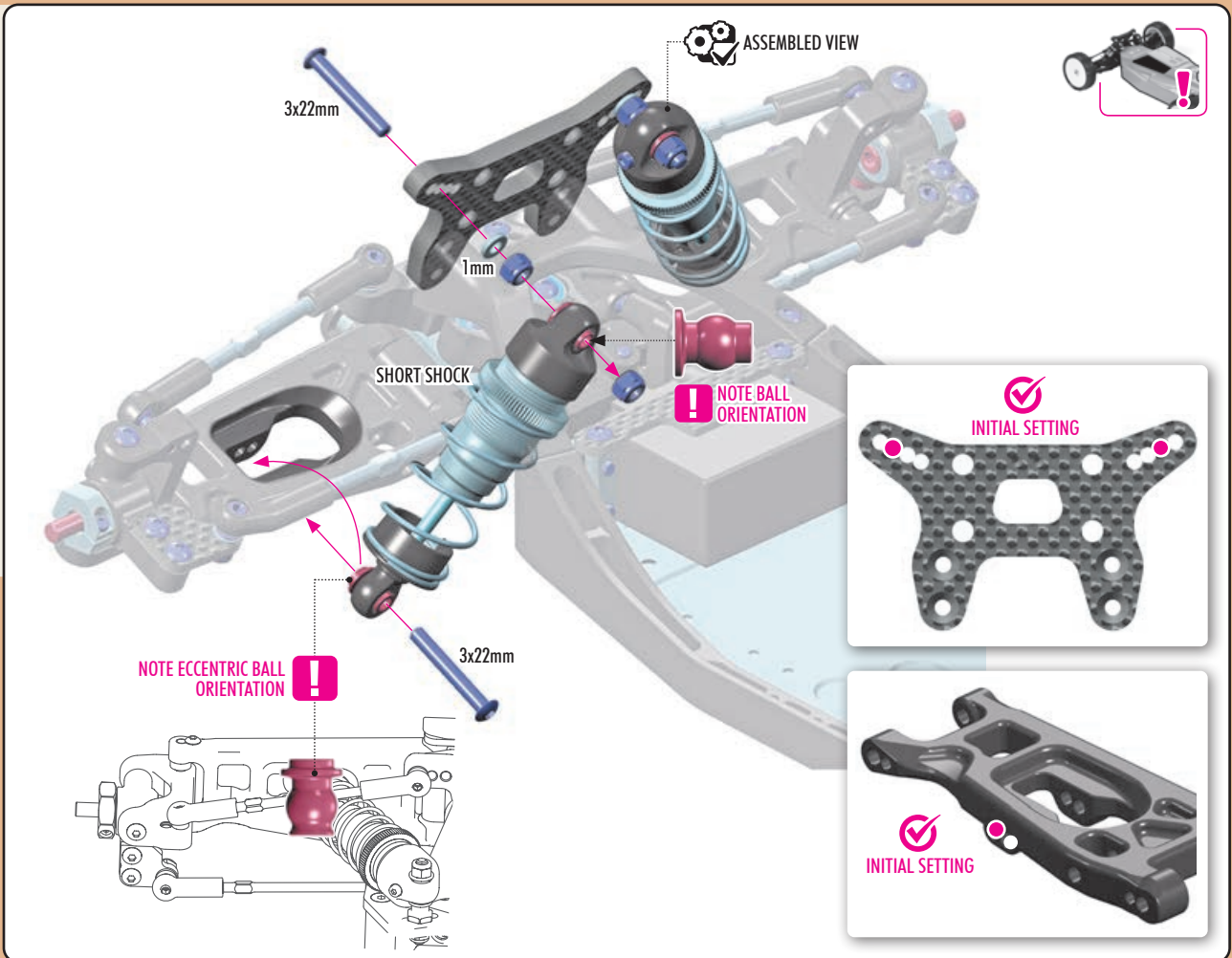
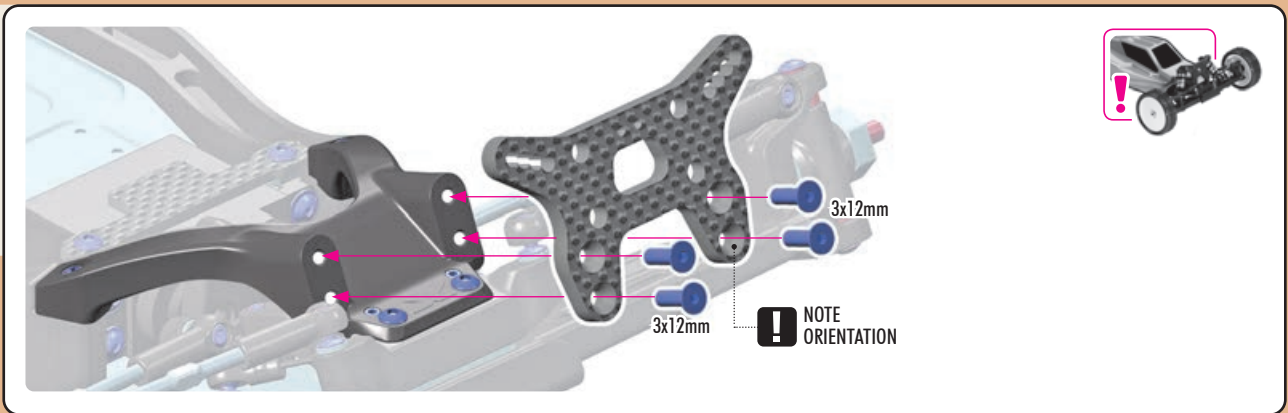
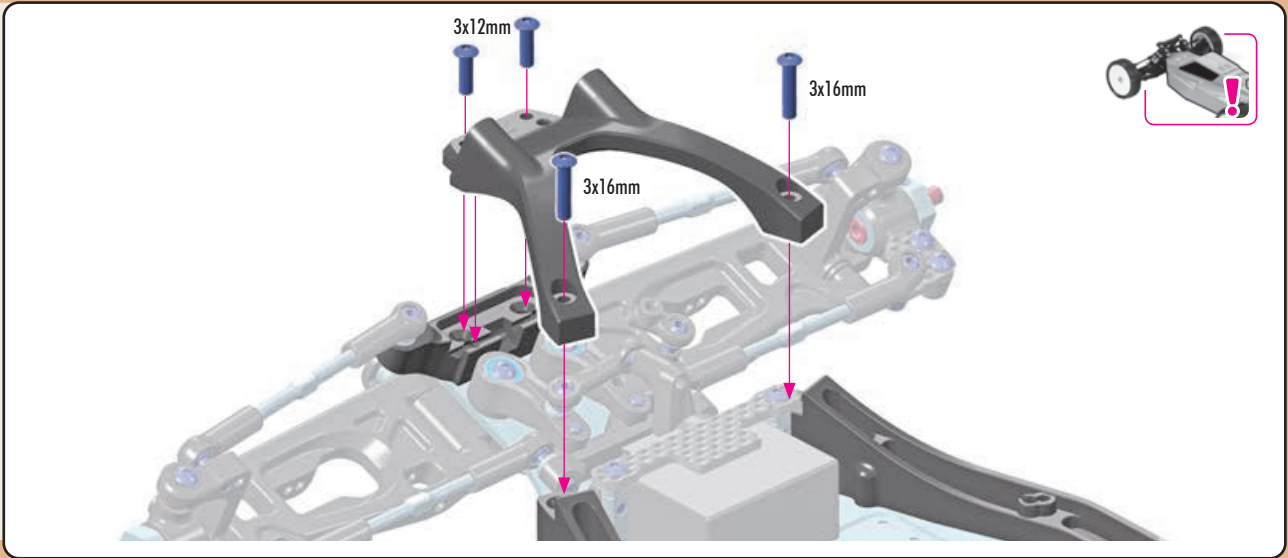
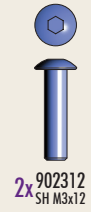

7. FINAL ASSEMBLY

2x 902256 SH M2.5x6



TIGHTEN GENTLY

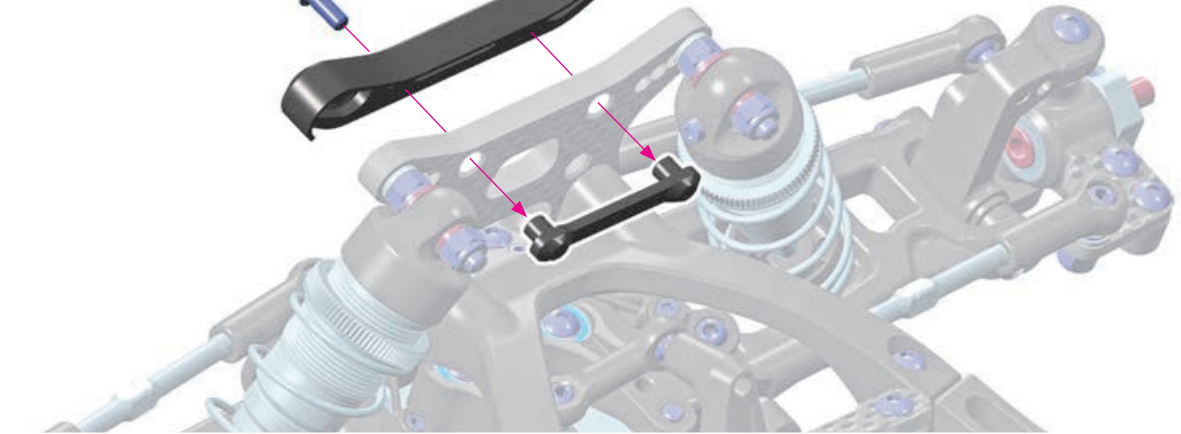
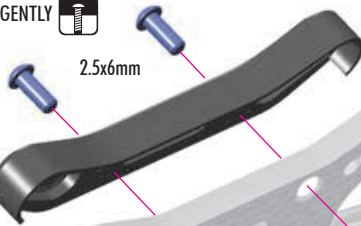

2x 902314 SH M3x14



4x 960030 NUT M3

2x LEFT = RIGHT

ASSEMBLED VIEW

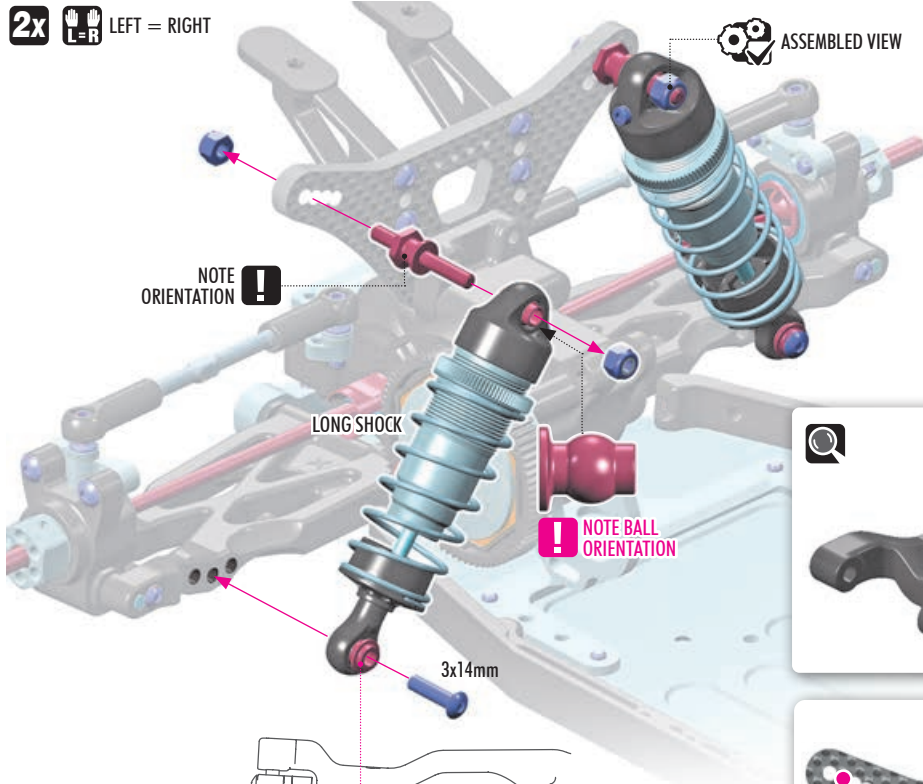

NOTE ORIENTATION

LONG SHOCK

NOTE BALL ORIENTATION

3x14mm

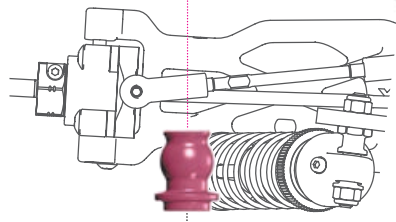

NOTE ECCENTRIC BALL ORIENTATION



INITIAL SETTING

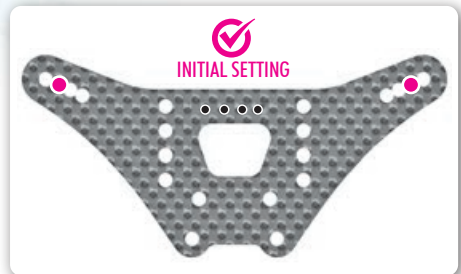

INITIAL SETTING

#362390 ALU REAR SHOCK ABSORBER ADAPTER (1+1) - SET



#901308 HEX SCREW SB M3x8 (10)
 #902312 HEX SCREW SH M3x12 (10)
 #903308 HEX SCREW SFH M3x8 (10)

7. FINAL ASSEMBLY

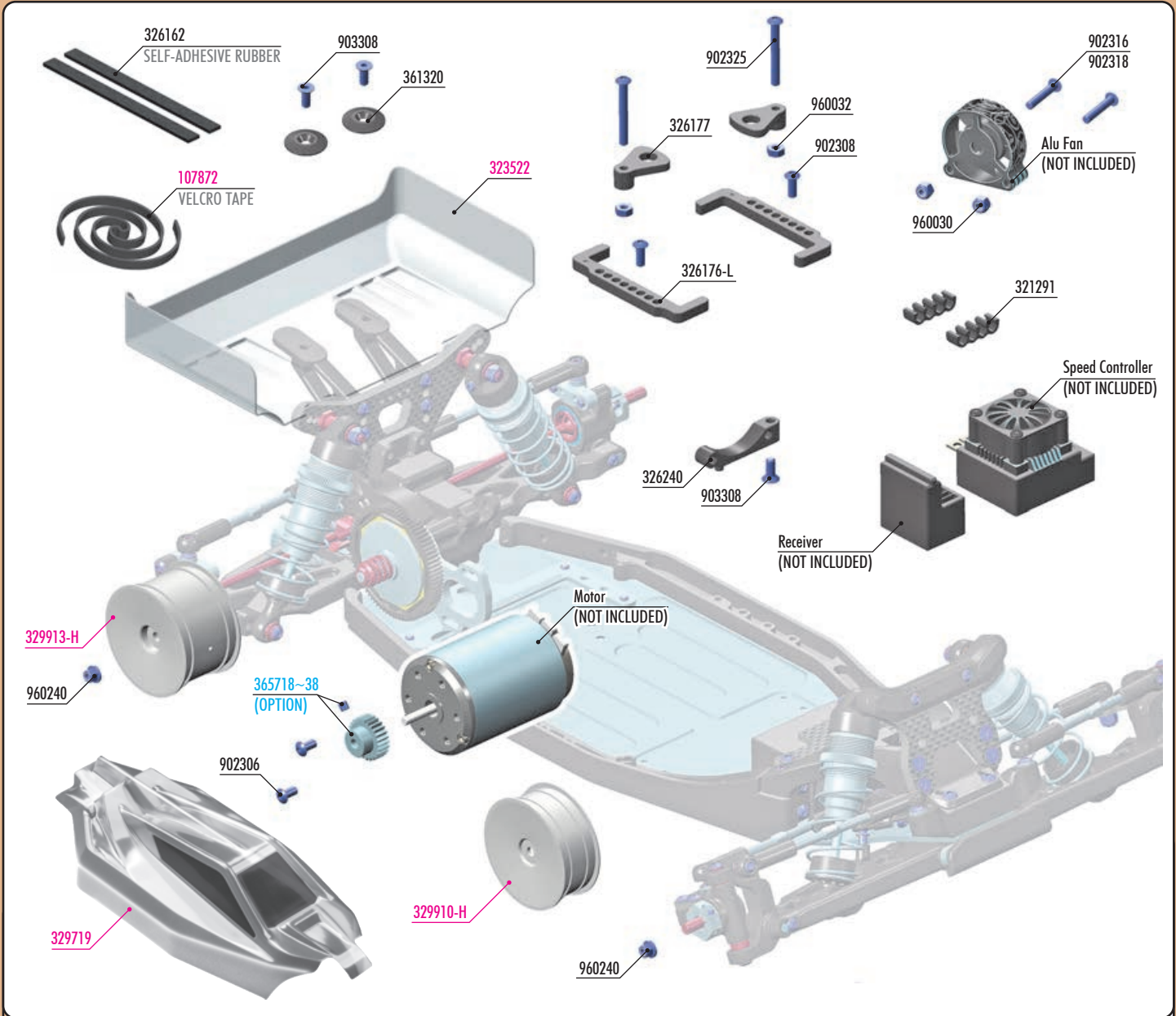

329913-H

960240

365718-38
(OPTION)

902306

329719

329910-H

960240

Motor
(NOT INCLUDED)

Receiver
(NOT INCLUDED)

Speed Controller
(NOT INCLUDED)

Alu Fan
(NOT INCLUDED)

326162
SELF-ADHESIVE RUBBER

903308

361320

107872
VELCRO TAPE

323522

902325

902316

902318

960032

902308

326177

326176-L

960030

321291

326240

903308

BAG

07

321291 COMPOSITE 5-WIRES HOLDER - SET
326162 SELF-ADHESIVE RUBBER 1.5x6.5x155mm (2)
326176-L COMPOSITE LIPO BATTERY HOLDER - LONG (2+2)
326177 COMPOSITE BATTERY CLAMP (2)
326240 COMPOSITE FAN HOLDER
361320 BODY MOUNT, BATTERY MOUNT - V2 & WING SHIM (2)

902306 HEX SCREW SH M3x6 (10)
902308 HEX SCREW SH M3x8 (10)
902316 HEX SCREW SH M3x16 (10)
902318 HEX SCREW SH M3x18 (10)
902325 HEX SCREW SH M3x25 (10)

903308 HEX SCREW SFH M3x8 (10)
960030 NUT M3 (10)
960032 NUT M3 (10)
960240 NUT M4 WITH SERRATED FLANGE (10)

107872 VELCRO TAPE WITH DOUBLE SIDED TAPE 8x500mm
323522 LEXAN REAR WING - LUSH
329719 BODY FOR 1/10 2WD OFF-ROAD BUGGY - EPSILON 2D - LIGHT
329910-H 2WD FRONT WHEEL AERODISK WITH 12MM HEX - WHITE - HARD (2)
329913-H REAR WHEEL AERODISK WITH 12MM HEX IFMAR - WHITE - HARD (2)

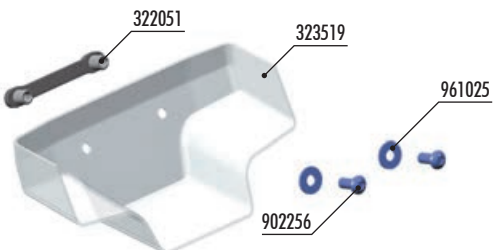

322051

323519

961025

902256

326149

913203

#326152
OPTION STAINLESS STEEL WEIGHT FOR ELECTRONICS FOR 1-PIECE CHASSIS 30G

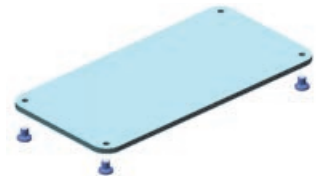

BAG

07.1

XB2 FINAL ASSEMBLY SET

322051 COMPOSITE FRONT SHOCK TOWER INSERT (2)
323519 LEXAN FRONT WING - WIDE - RIBBED
326149 CARBON PLATE FOR ELECTRONICS FOR 1-PIECE CHASSIS - SET

902256 HEX SCREW SH M2.5x6 (10)
913203 HEX SCREW 110° SFH M2x3 (10)
961025 WASHER S 2.5 (10)

7. FINAL ASSEMBLY

2x 902306
SH M3x6

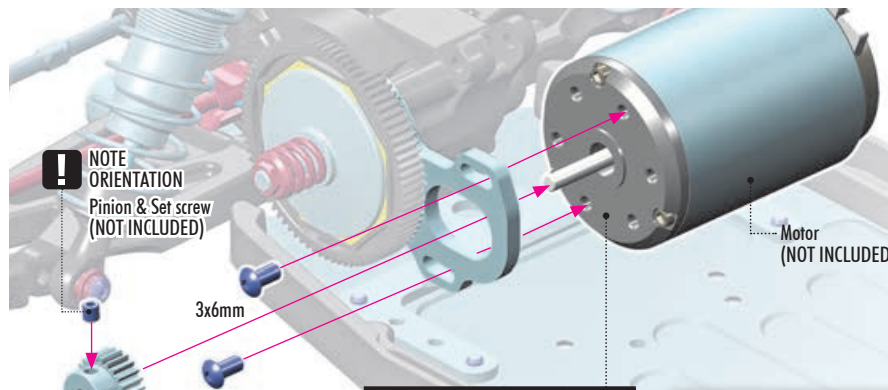

NOTE
ORIENTATION
Pinion & Set screw
(NOT INCLUDED)

3x6mm

Motor
(NOT INCLUDED)

GEAR RATIO Final Drive Ratio
 $78 : X \times 2.65 = \text{FDR}$
 (Spur) (Pinion) (IGR)

RECOMMENDED INITIAL COMBINATIONS

Motor	Spur	Pinion	Ratio
4.5T	78T	21T	9.84
5.5T	78T	22T	9.39
6.5T	78T	23T	8.98
7.5T	78T	24T	8.61
8.5T	78T	25T	8.26
13.5T	72T	28T	6.81
17.5T	72T	32T	5.96

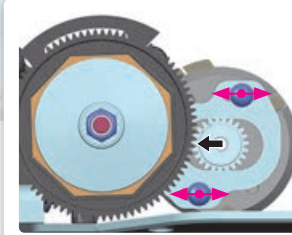

GEAR MESH

Adjust the motor so the pinion meshes with the spur gear properly. Make sure the gear mesh is NOT too tight.

There should be a small amount of play between the teeth of the pinion gear and the spur gear.

4x 913203
SFH M2x3

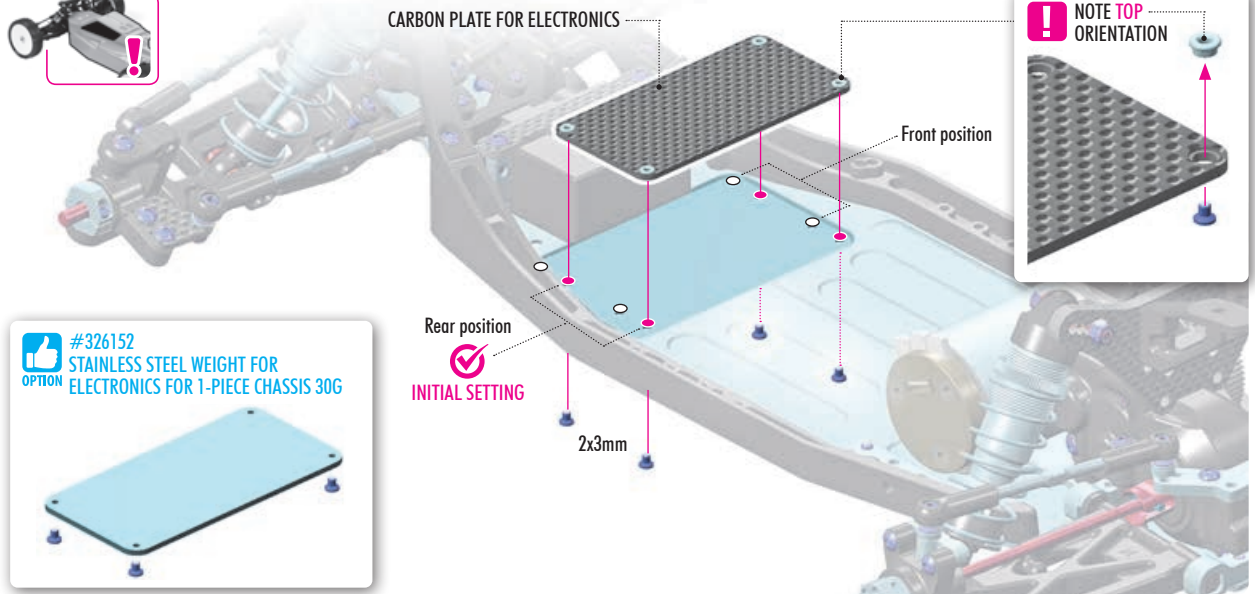

CARBON PLATE FOR ELECTRONICS

NOTE TOP ORIENTATION

Front position

Rear position
INITIAL SETTING

2x3mm

#326152
OPTION STAINLESS STEEL WEIGHT FOR ELECTRONICS FOR 1-PIECE CHASSIS 30G

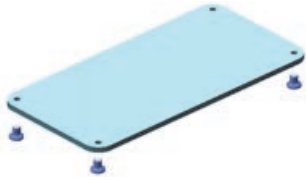

Speed Controller
(NOT INCLUDED)

Receiver
(NOT INCLUDED)

#107876
OPTION HUDY ULTRA THIN DOUBLE-SIDED TAPE - SINGLE STRIP (5)

#107875
OPTION HUDY DOUBLE-SIDED TAPE

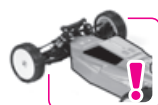

7. FINAL ASSEMBLY



2x 902308
SH M3x8



2x 902325
SH M3x25



2x 960032
NUT M3

NOTE ORIENTATION
for LOW BATTERY PACK

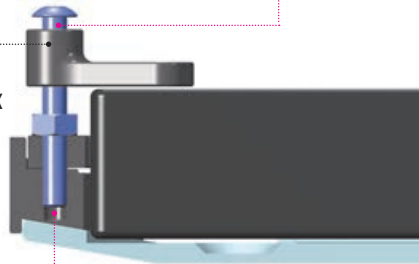

! To ensure correct functioning of the battery holder, DO NOT overtighten the screw; the holder must be able to move.

NOTE ORIENTATION
for STANDARD BATTERY PACK



! DO NOT overtighten the screw to avoid side guard damage.

#326181
STAINLESS STEEL BATTERY WEIGHT 35g
OPTION



Battery
(NOT INCLUDED)



! BATTERY POSITION SETTING
For INITIAL SETTING place battery in maximum rearward location.

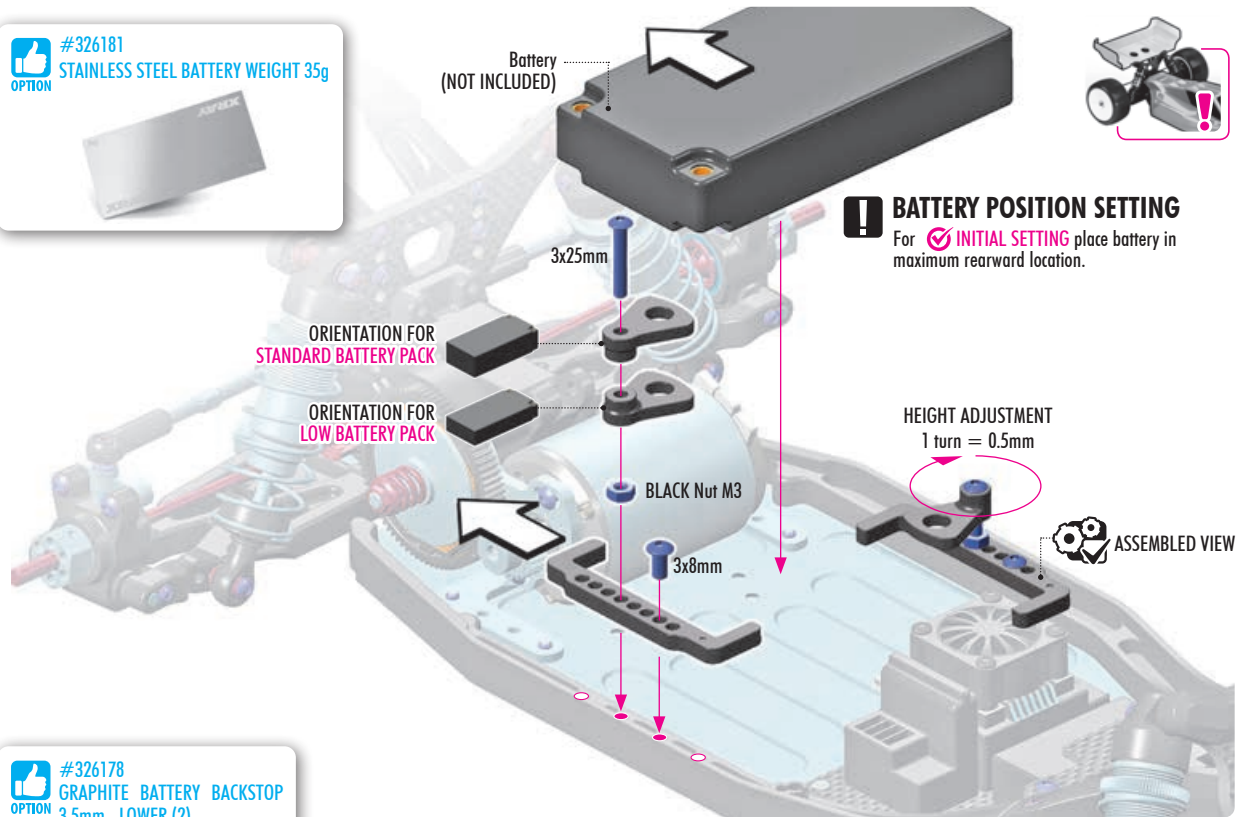

#326178
GRAPHITE BATTERY BACKSTOP
3.5mm - LOWER (2)
OPTION



REAR

! INITIAL SETTING

DOT FRONT ORIENTATION

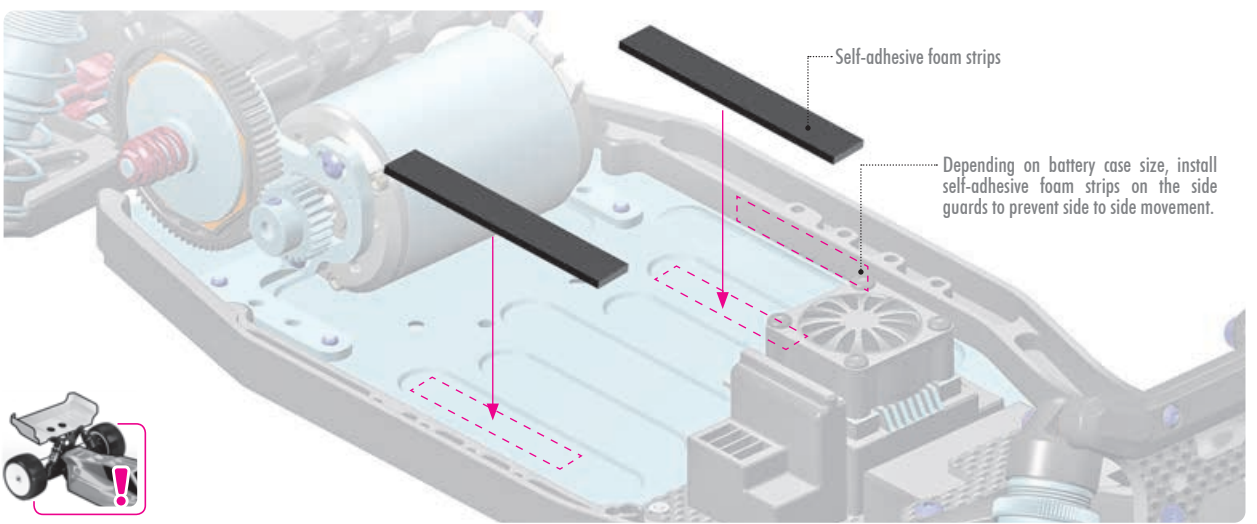
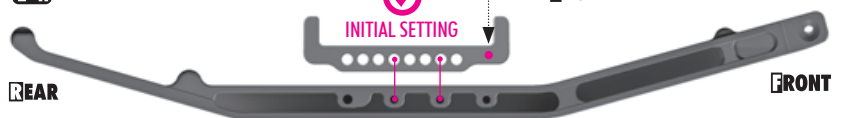

7. FINAL ASSEMBLY

BATTERY WEIGHT BALANCE ADJUSTMENT

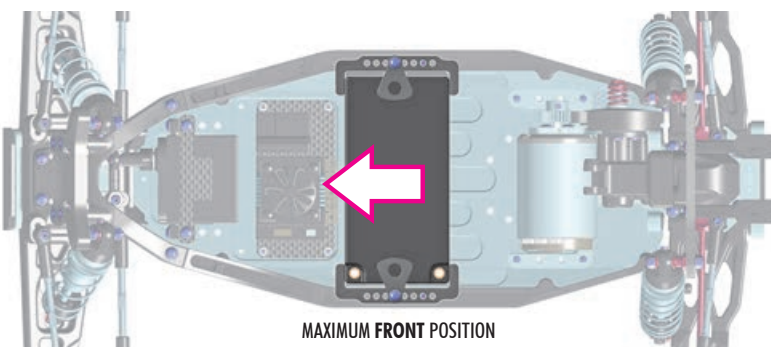
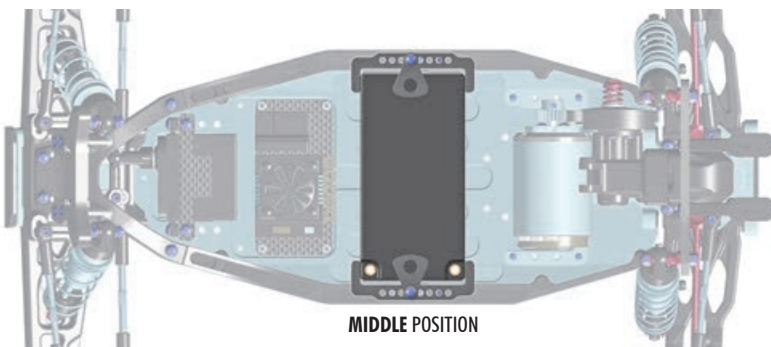
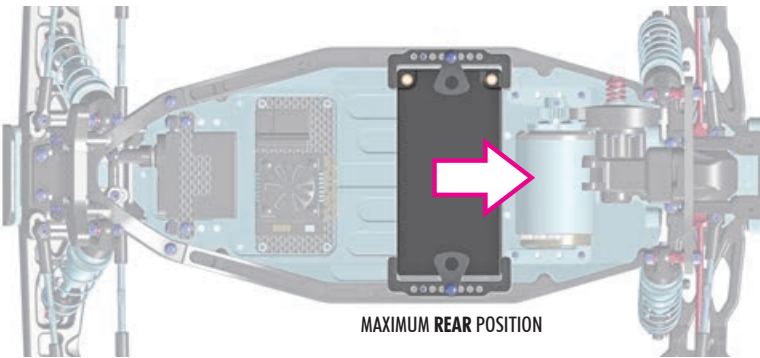
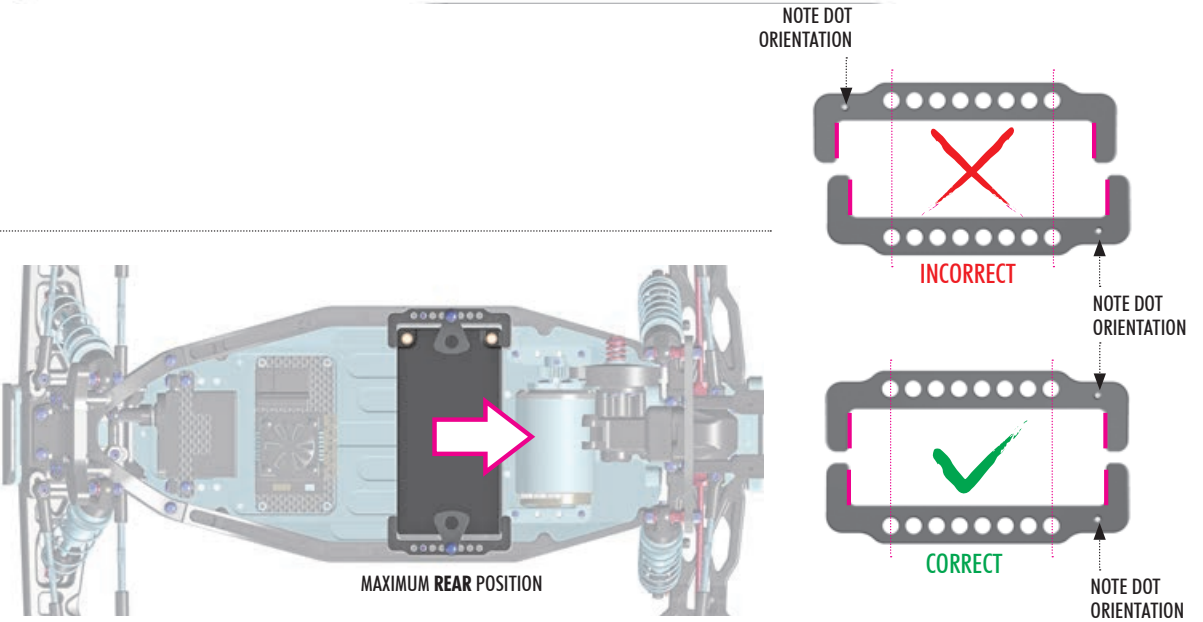
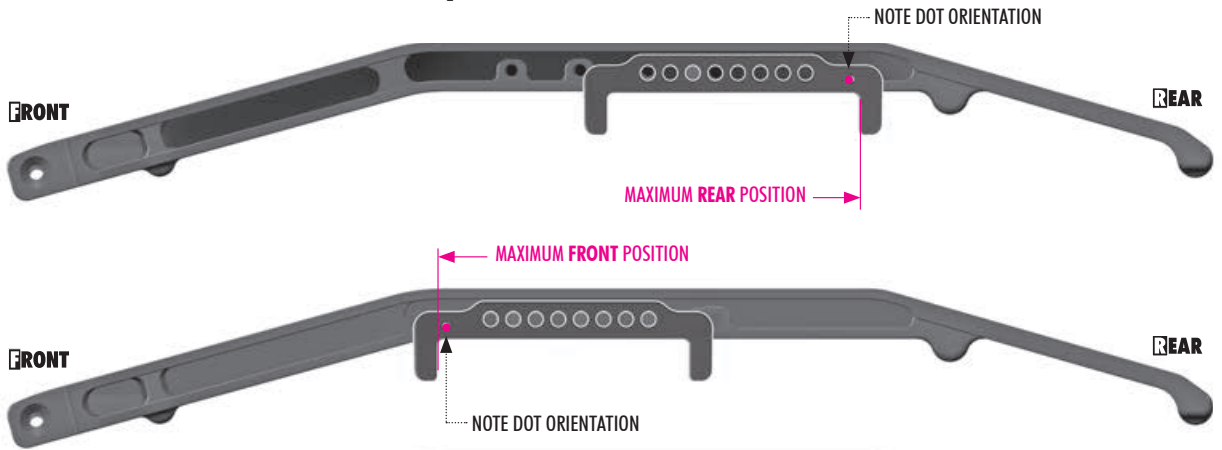

7. FINAL ASSEMBLY

ALTERNATIVE 1

FAN ASSEMBLY BEHIND MOTOR

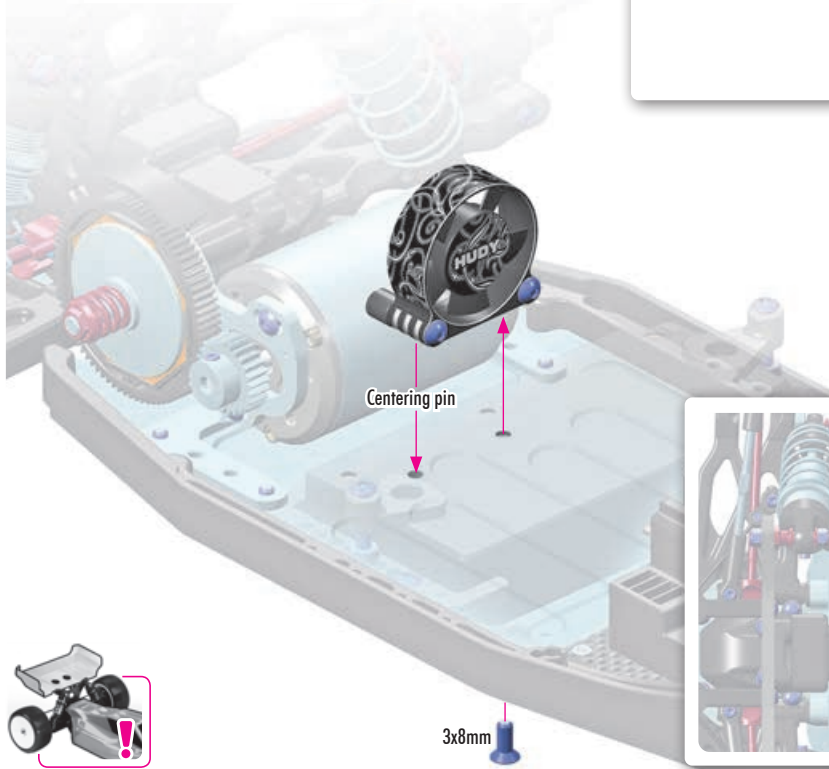
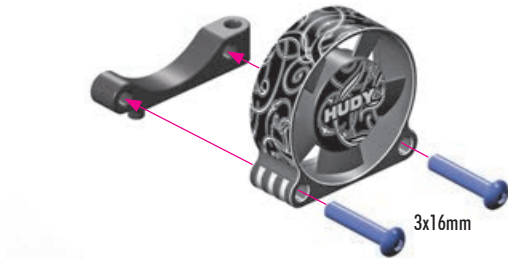

FAN (NOT INCLUDED)

#293101
HUDY ALU RC FAN 30MM
SIDE MOUNT 2 HOLE

OPTION

#293112
HUDY BRUSHLESS RC FAN 30MM
WITH INTERNAL SOLDERING TABS

OPTION

#293110
HUDY BRUSHLESS RC FAN 30MM
WITH EXTERNAL SOLDERING TABS

OPTION

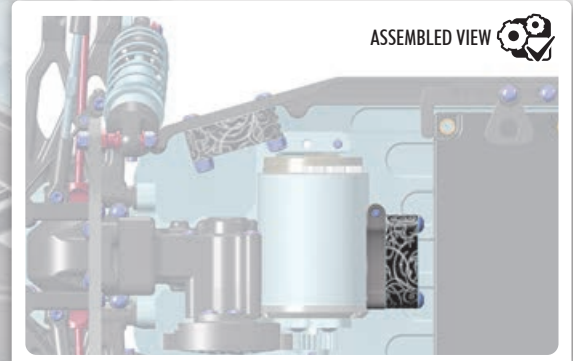

ALTERNATIVE 2

FAN ASSEMBLY BETWEEN BATTERY & MOTOR

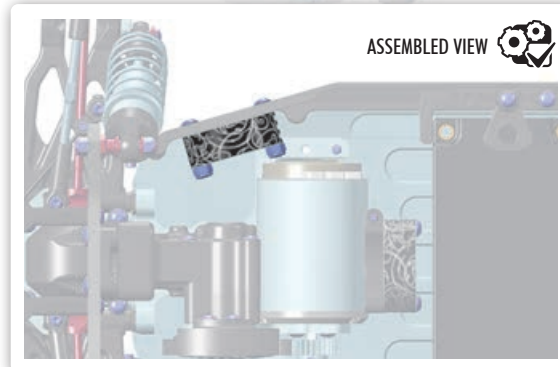
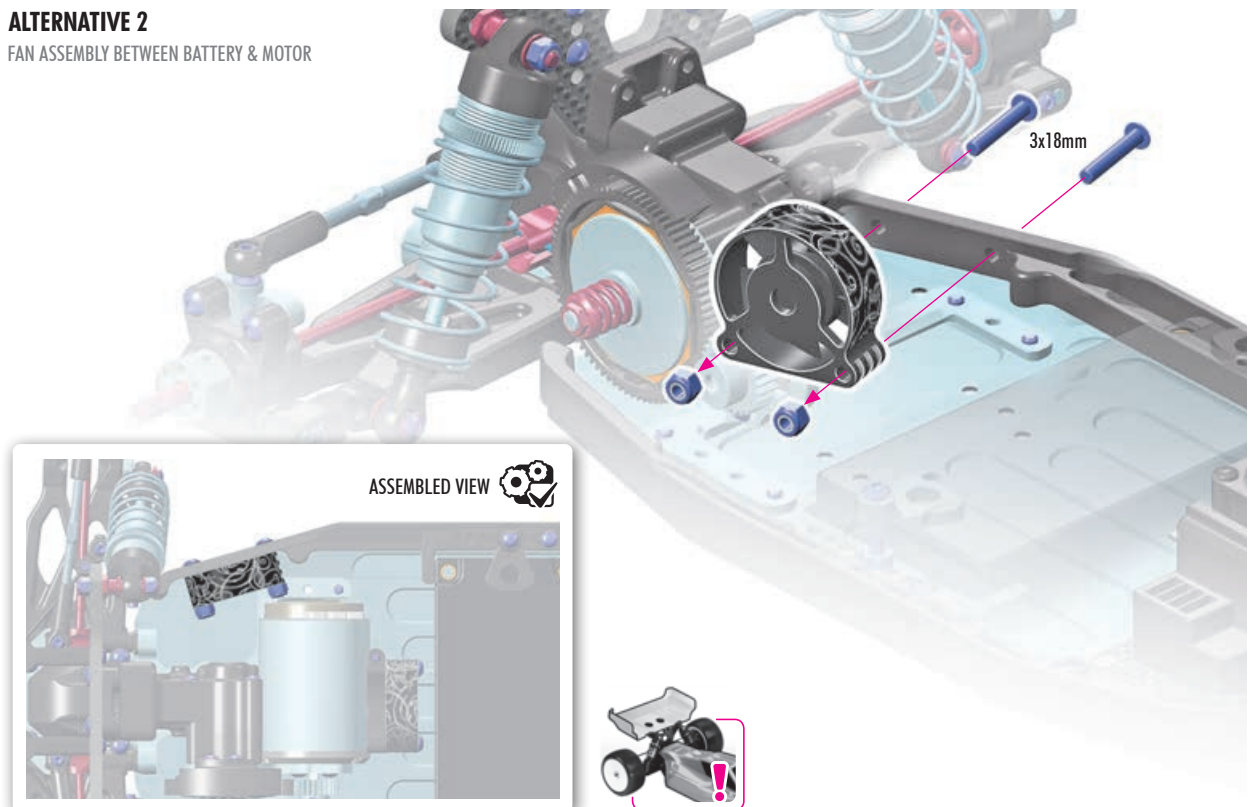

7. FINAL ASSEMBLY

- ❶ Before cutting and making holes on the BODY, put the unpainted body on the chassis to confirm the mounting position and location for holes and cutouts. Before cutting and making holes on the WING, put the unpainted wing on the wing holders to confirm the mounting position and location for holes and cutouts.
- ❷ Before painting, wash the inside of the body with mild detergent, and then rinse and dry thoroughly.
- ❸ Mask all windows.
- ❹ Apply paint masks as appropriate.
- ❺ Paint the body using paints formulated for polycarbonate bodies.
- ❻ When the paint is dry, remove the masking.



- ❼ Carefully cut out the body using appropriate scissors or cutting tools.
- ❽ When you have finished cutting, peel off the external protective films.

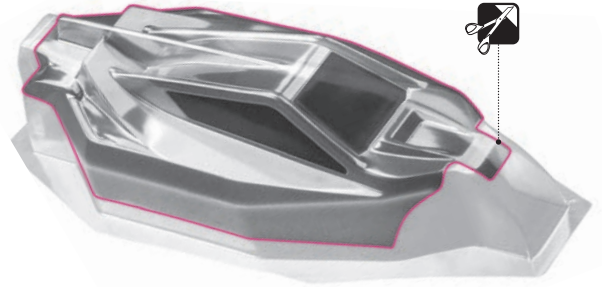

XRAY LEXAN BODY

OPTION	#	THICK	EPSILON 2DL	INCLUDED
	#329719	THIN	EPSILON 2DL	INCLUDED
	#329718	THICK	PSILON 2D	OPTION
	#329720	THICK	EPSILON 2C	OPTION
	#329721	THIN	EPSILON 2CL	OPTION

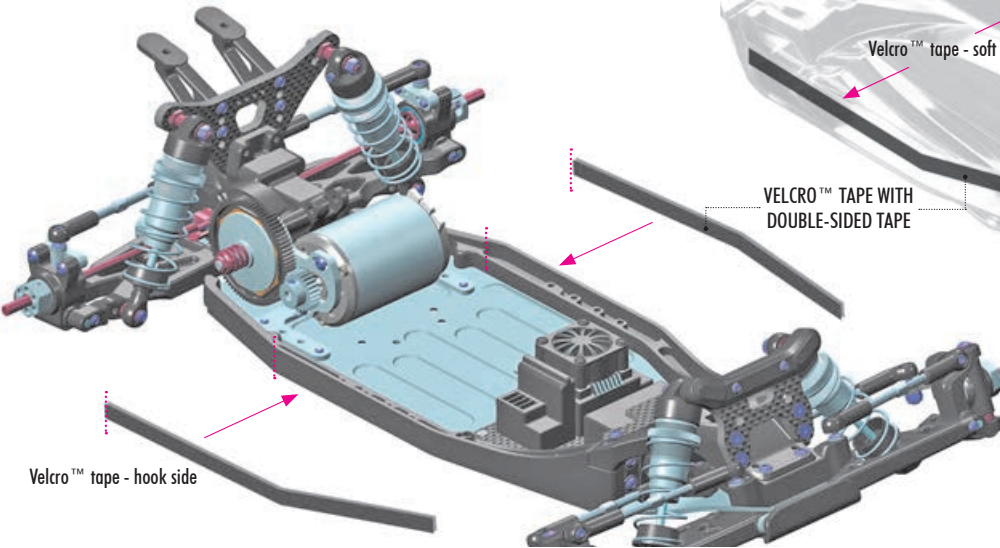

2x 902256
SH M2.5x6



2x 961025
S2.5

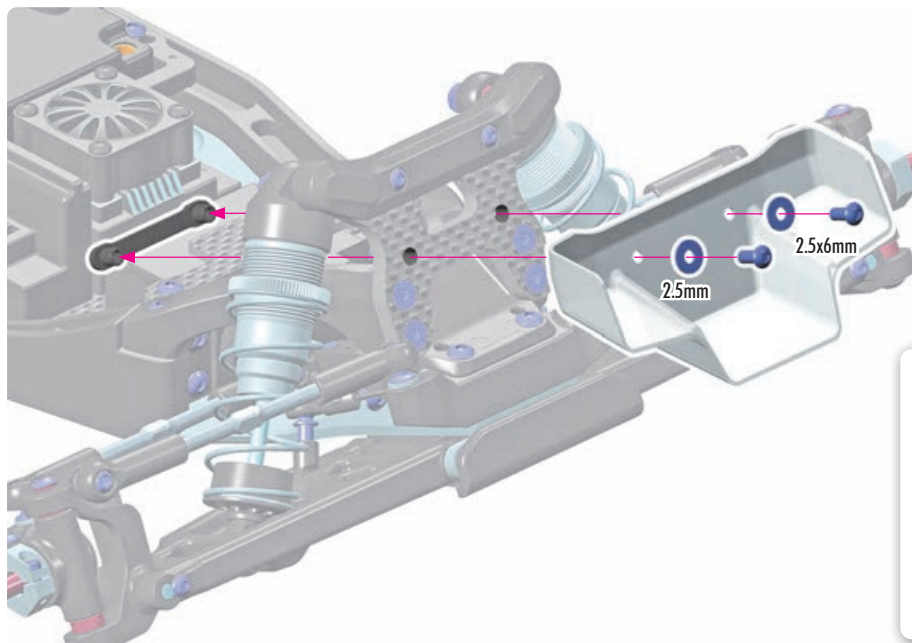

XRAY LEXAN FRONT WINGS

OPTION	#	WIDE	OPTION
	#323518	WIDE	OPTION
	#323519	WIDE-RIBBED	INCLUDED



7. FINAL ASSEMBLY



XRAY LEXAN REAR WINGS			
#323510	THIN		OPTION
#323511	THICK		OPTION
#323513	THIN	RANK	OPTION
#323517	THIN	TEC	INCLUDED
#323522	THIN	LUSH	INCLUDED
#323523	THICK	LUSH	OPTION



PINIONS (48P)			
#294017	17T	#365728	28T
#305918	18T	#365729	29T
#305919	19T	#365730	30T
#294020	20T	#365731	31T
#294021	21T	#365732	32T
#294022	22T	#365733	33T
#294023	23T	#365734	34T
#305924	24T	#365735	35T
#305925	25T	#365736	36T
#365726	26T	#365737	37T
#365727	27T	#365738	38T

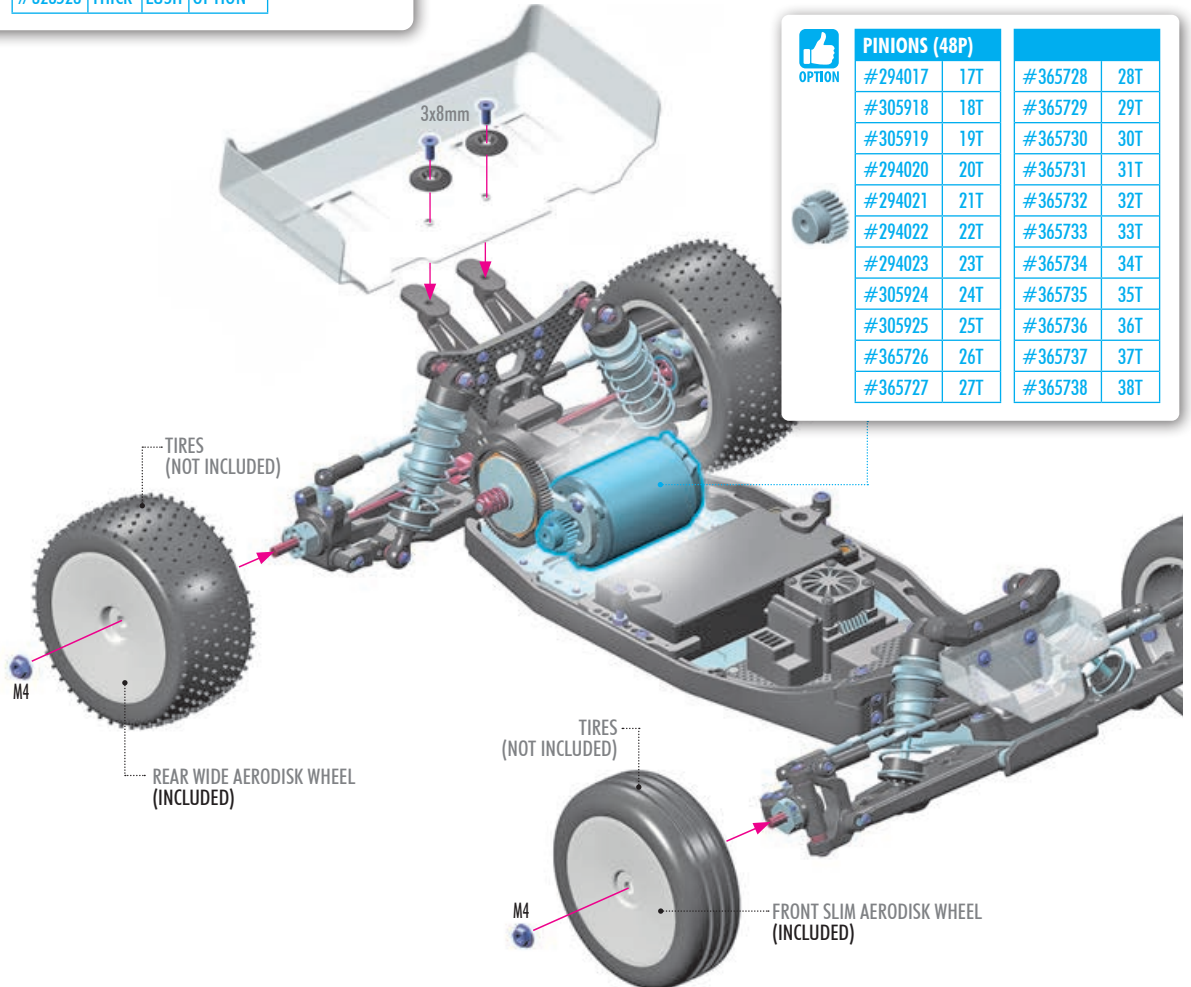

XRAY FRONT AERODISK WHEELS				
#329900-M	MEDIUM	WHITE	10pcs	OPTION
#329900-H	HARD	WHITE	10pcs	OPTION
#329900-Y	HARD	YELLOW	10pcs	OPTION
#329904-M	MEDIUM	SLIM WHITE	10pcs	OPTION
#329904-Y	MEDIUM	SLIM YELLOW	10pcs	OPTION



XRAY FRONT AERODISK WHEELS				
#329910-M	MEDIUM	WHITE	2pcs	OPTION
#329910-H	HARD	WHITE	2pcs	INCLUDED
#329910-Y	HARD	YELLOW	2pcs	OPTION
#329914-M	MEDIUM	SLIM WHITE	2pcs	OPTION
#329914-Y	MEDIUM	SLIM YELLOW	2pcs	OPTION



XRAY REAR AERODISK WHEELS				
#329901-H	HARD	WHITE	10pcs	OPTION
#329901-Y	HARD	YELLOW	10pcs	OPTION



XRAY REAR AERODISK WHEELS				
#329913-H	HARD	WHITE	2pcs	INCLUDED
#329913-Y	HARD	YELLOW	2pcs	OPTION

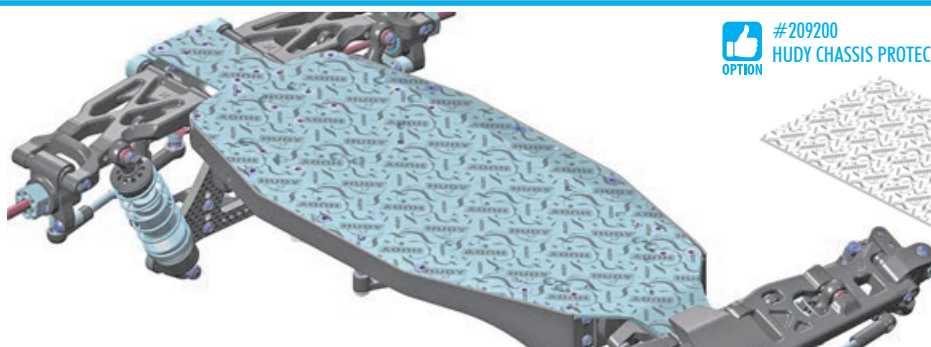

#209200 HUDY CHASSIS PROTECTOR VINYL STICKER 360x125mm

OPTION PARTS

(NOT INCLUDED)



#320905

XB2 5G GEAR BOX CONVERSION SET

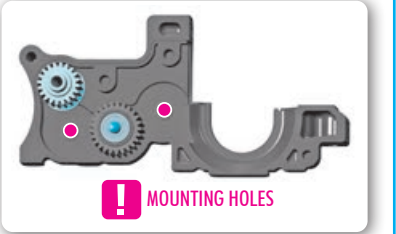
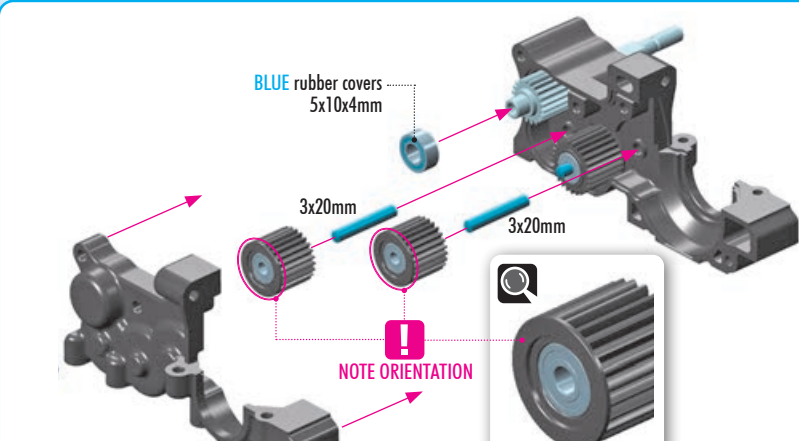
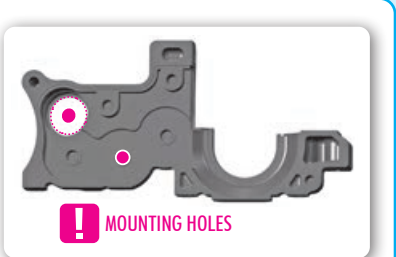
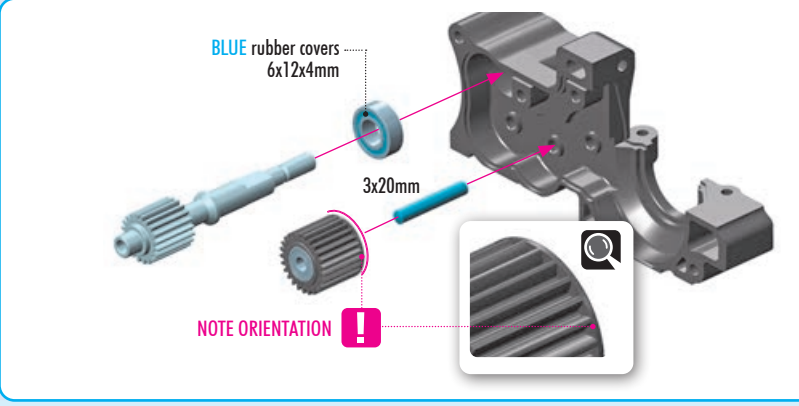
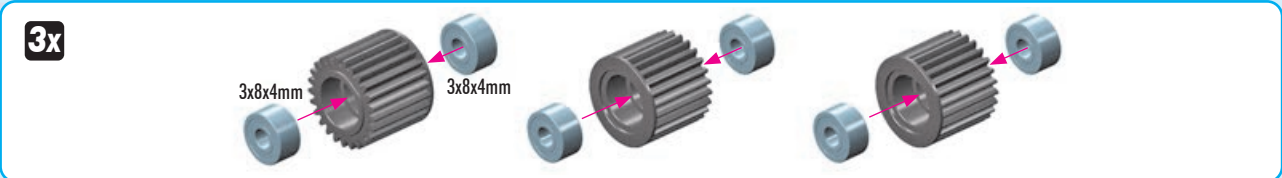
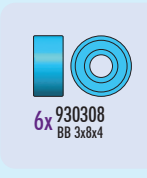
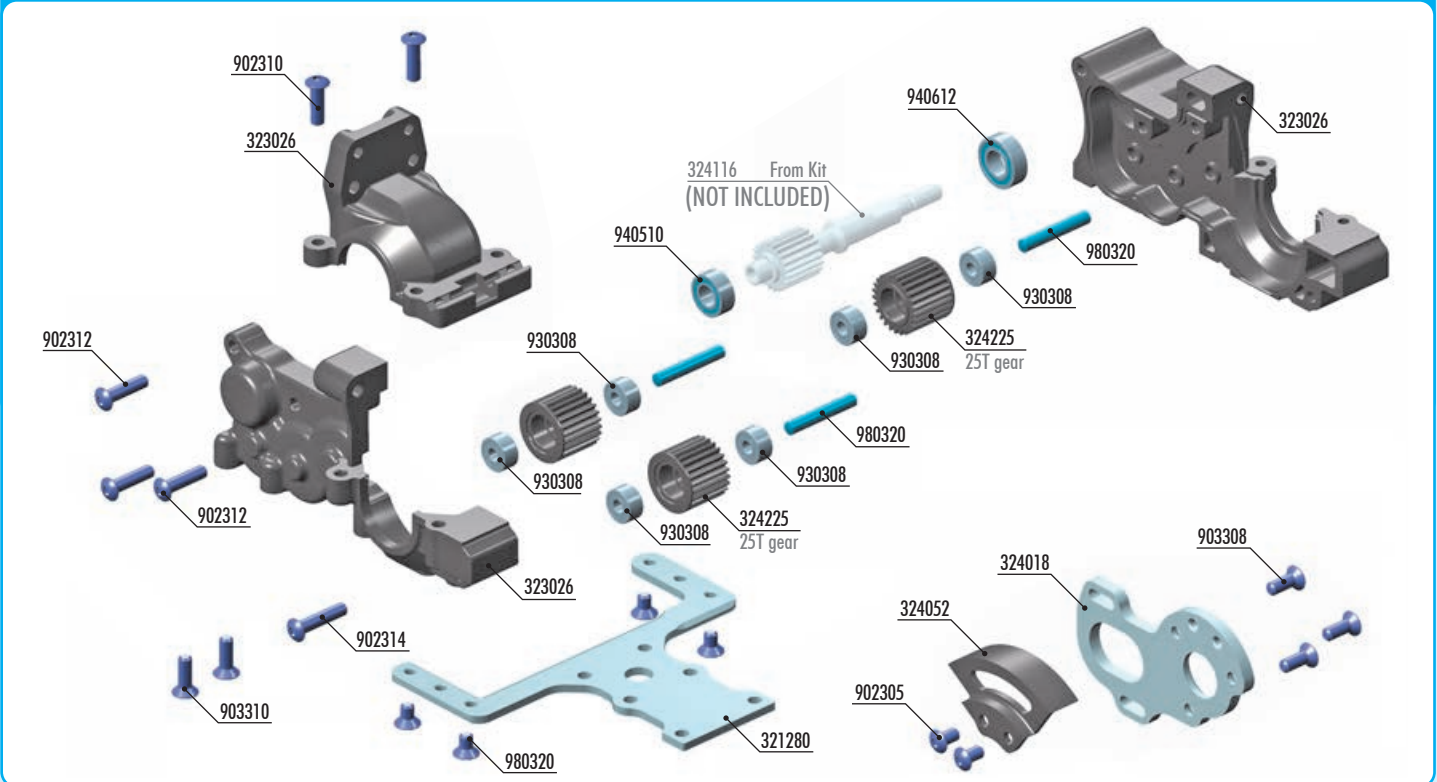

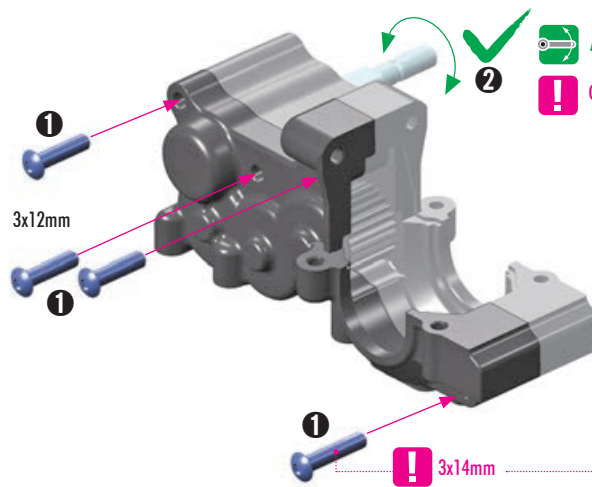
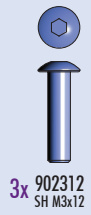

After assembly, check for free rotation of all drivetrain parts.

Correct teeth play will be achieved after the final chassis assembly.

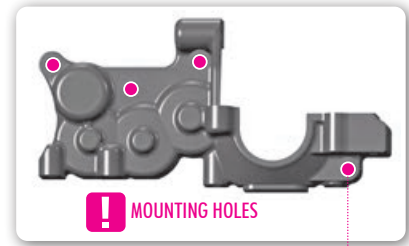

Next follow the 5G Gear Box assembly instructions following these pages and steps:

Page 12 / step 1 + step 2 + 3 step

Page 13 / step 1 + step 2 + step 3

Page 15 / step 1

Page 16 / step 1 + step 2

Some of the screws must be used from the kit.

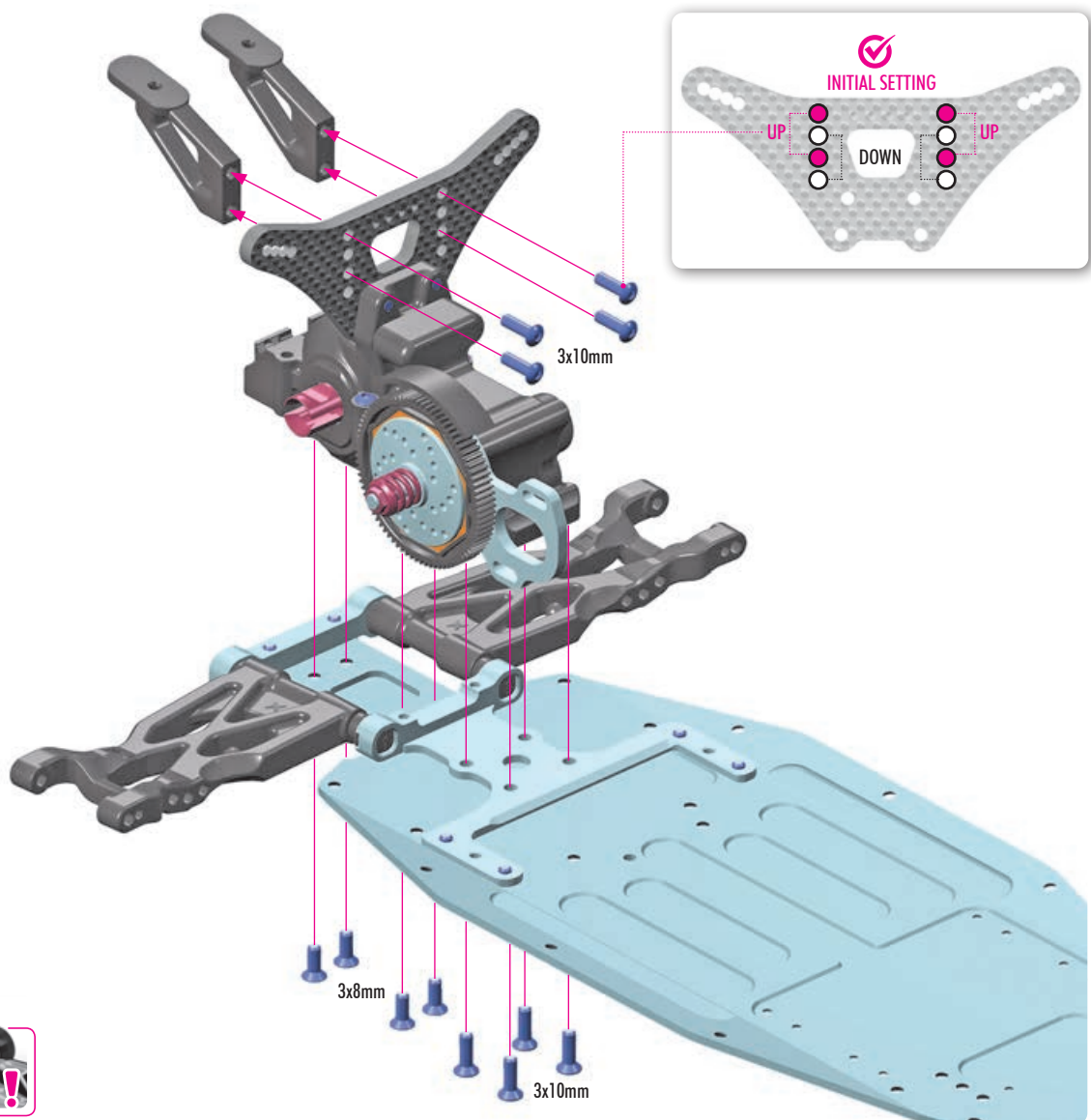
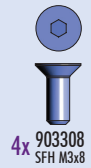
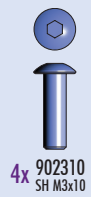

OPTION PARTS

(NOT INCLUDED)



#325101

XRAY XB2 ACTIVE DIFF - NARROW - SET

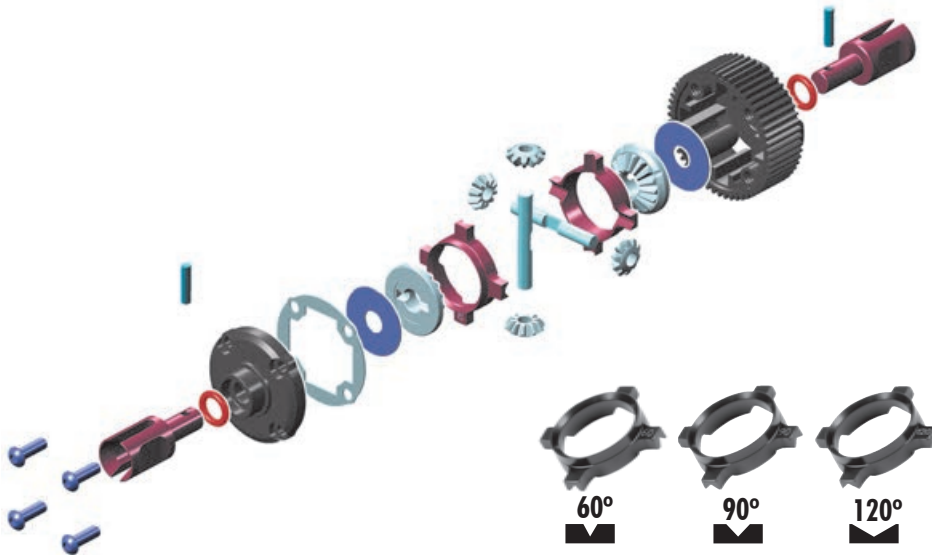

ACTIVE DIFF ON - AND OFF-POWER ACTION	
ACTION	EFFECT
OFF-POWER	The Active Diff behaves the same as a standard gear differential. Adjustments are made using different viscosities of silicone oils; thinner oils resulting in more off-power steering with a more aggressive feel.
ON-POWER	The main advantage of the Active Diff is felt on-power. The diff action become heavier when throttle is applied, increasing forward drive and stability upon corner exit.

	ACTIVE DIFF SEGMENTS	LOCK ON-POWER	TRACK CONDITIONS
#325123	60° OPTION		LOW
#325125	90° OPTION		MEDIUM
#325127	120° INCLUDED		HIGH

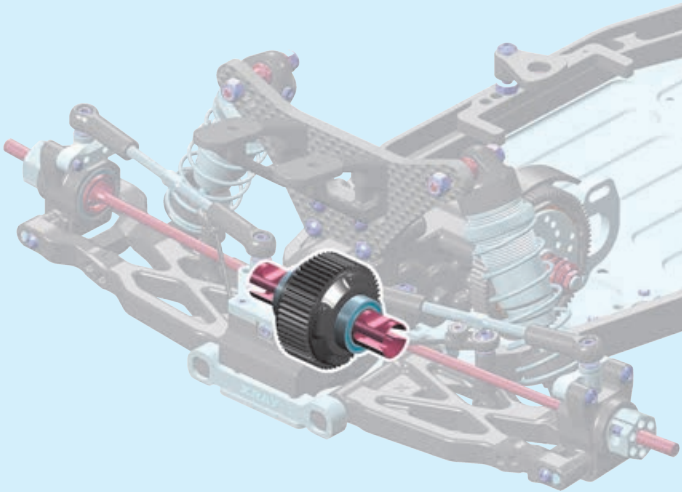

#335080 STEEL DIFFERENTIAL PIN HARDCOATED (2)



#335081 ALU DIFFERENTIAL PIN HARDCOATED (2)



#304932 GRAPHITE GEAR DIFF BEVEL & SATELLITE GEARS (2+4)



GEAR DIFF. CASES		
#324912	HARD	INCLUDED
#324912-G	GRAPHITE	OPTION
GEAR DIFF. PULLEYS		
#324955	HARD	INCLUDED
#324955-G	GRAPHITE	OPTION



#320904

ALU STEERING BLOCKS & C-HUBS WITH BACKSTOP - SET

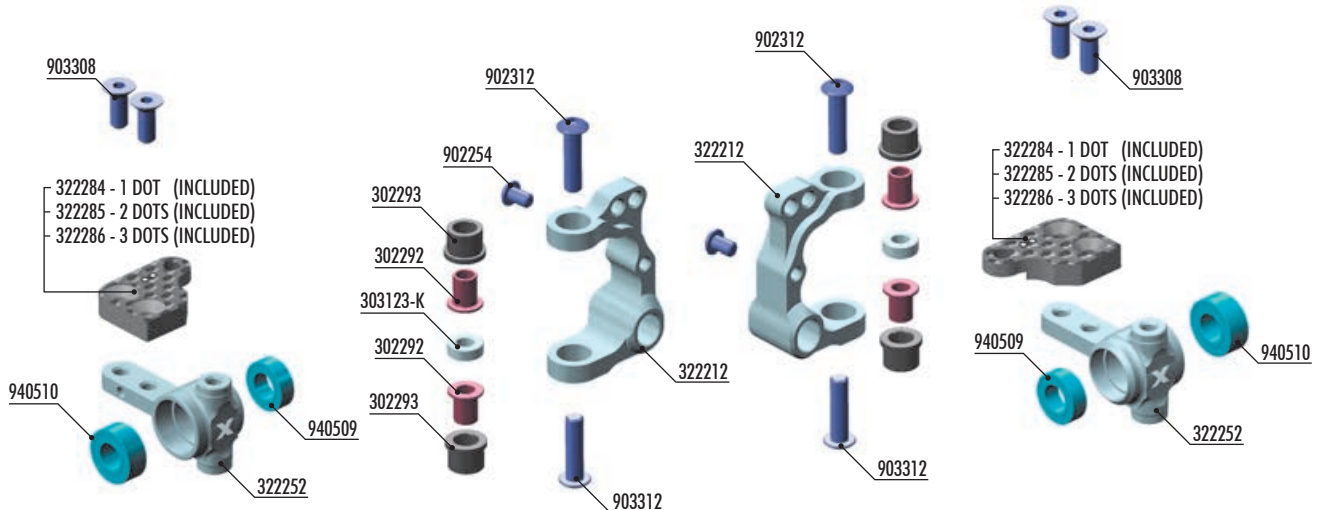

2x 303123-K SHIM 3x6x2

2x 902254 SH M2.5x4

4x 902312 SH M3x12

4x 903308 SH M3x6

2x 940509 BB 5x9x3

2x 940510 BB 5x10x4

2x

INITIAL SETTING
2 Dots

ASSEMBLED VIEW

! It is NOT possible to combine aluminum blocks & c-hubs with composite ones.

!

2x 902254 SH M2.5x4

2x 306219 SHIM 3x6x1

2x 306219 SHIM 3x6x2

From KIT 1mm

Caster Eccentric Bushings from KIT

From KIT 2mm

2x

2.5x4mm

!

2x 902254 SH M2.5x4

APPLY THREAD LOCK

! STEERING ANGLE SCREW 2.5x4mm must be used ONLY with 3 Dots steering plate.

The steering may LOCK when the steering angle screw is NOT used.

Steering angle of the **INSIDE** wheel.

3 Dots

INITIAL SETTING

2 Dots

1 Dot

2 Dots

3 Dots

1 Dot

Steering angle of the **OUTSIDE** wheel.

NOTE

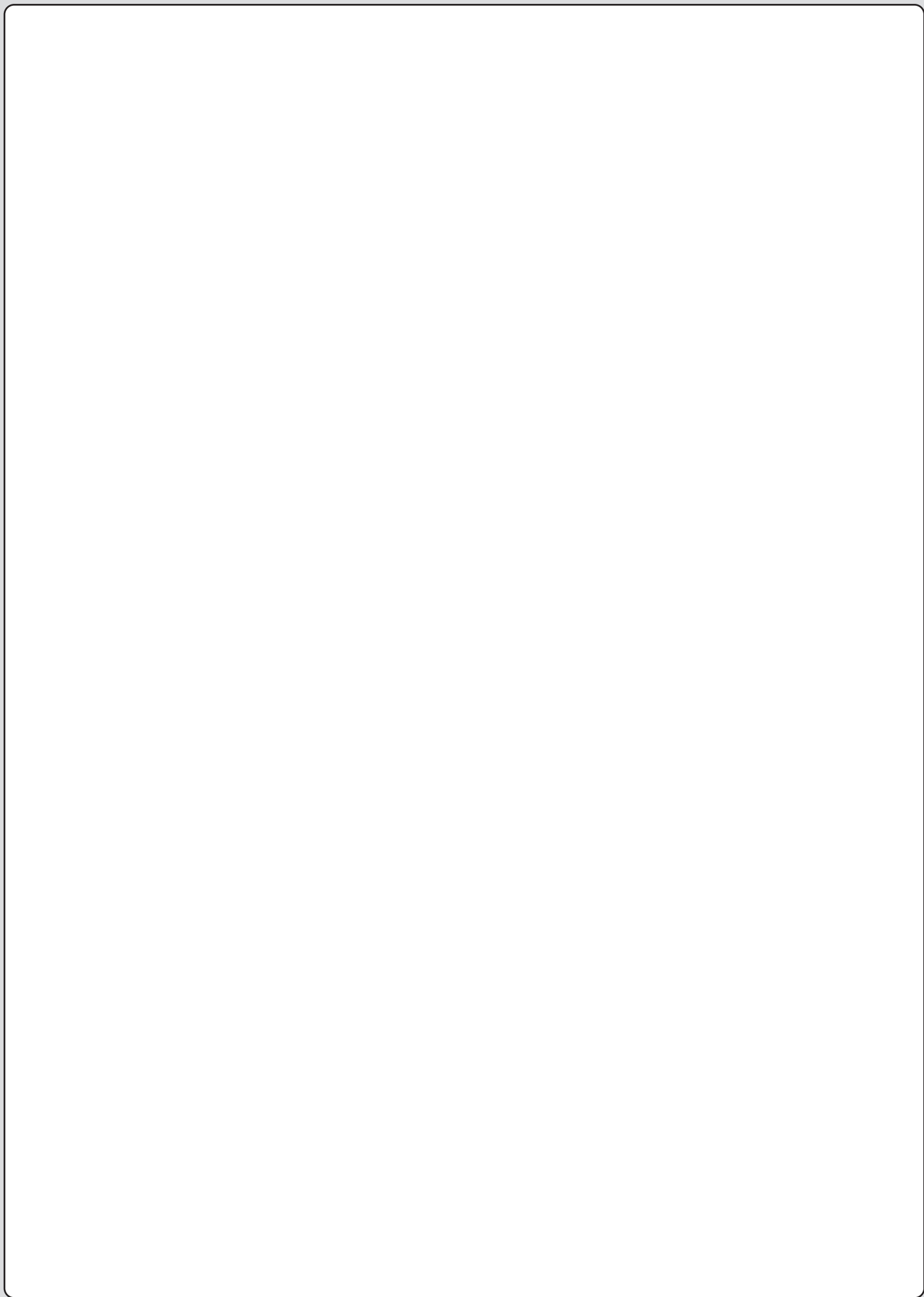

EXCLUSIVE PROFESSIONAL

HUDY

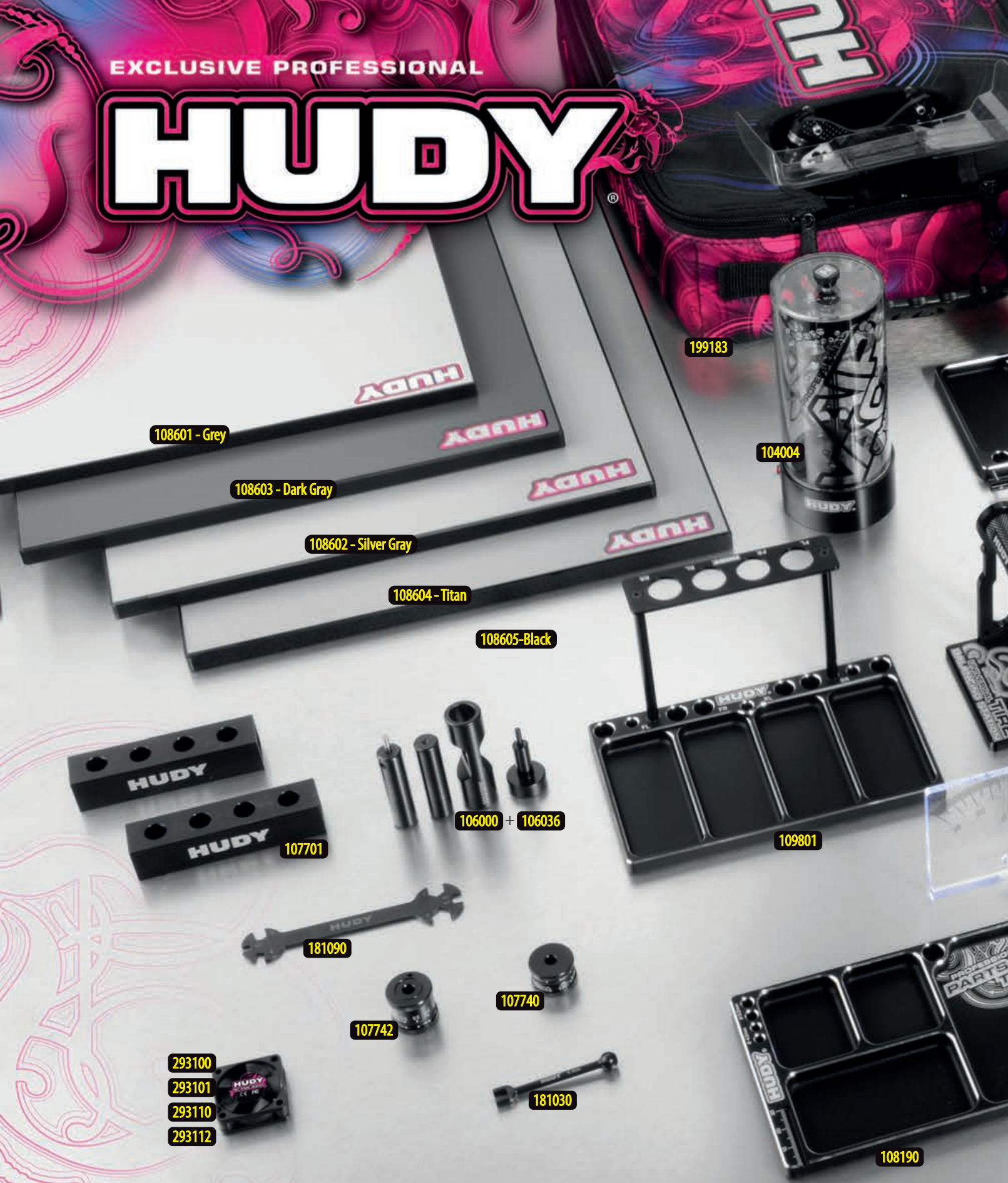

108601 - Grey

108603 - Dark Gray

108602 - Silver Gray

108604 - Titan

108605-Black

199183

104004

107701

106000 + 106036

109801

181090

107740

107742

181030

293100

293101

293110

293112

108190

- 104004 HUDY AIR VAC - VACUUM PUMP - 1/10 OFF-ROAD
- 105500 HUDY UNIVERSAL TIRE BALANCING STATION
- 105520 WHEEL ADAPTER FOR 1/10 TOURING CARS - 12MM
- 106000 HUDY DRIVE PIN REPLACEMENT TOOL (FOR 3MM PINS)
- 106036 EJECTOR PIVOT PIN & ALTERNATING PIVOT 2.5MM FOR #106000
- 107090 HUDY BEARING CHECKING TOOL
- 107601 LIMITED EDITION - REAMER FOR BODY 0-9MM + COVER - SMALL
- 107701 CHASSIS DROOP GAUGE SUPPORT BLOCKS 20MM FOR 1/8 - LW(2)
- 107740 HUDY ADJUSTABLE RIDE HEIGHT GAUGE 14-20MM
- 107742 HUDY ADJUSTABLE RIDE HEIGHT GAUGE 20-30MM
- 107855 HUDY PIT LED
- 107880 CHASSIS BALANCING TOOL (2)

- 108160 HUDY 1/10 OFF-ROAD CAR STAND - V2
- 108190 HUDY ALU TRAY FOR PARTS
- 108601 FLAT SET-UP BOARD FOR 1/10 OFF-ROAD - LIGHTWEIGHT - GREY
- 108602 FLAT SET-UP BOARD FOR 1/10 OFF-ROAD - LIGHTWEIGHT - SILVER GRAY
- 108603 FLAT SET-UP BOARD FOR 1/10 OFF-ROAD - LIGHTWEIGHT - DARK GREY
- 108604 FLAT SET-UP BOARD FOR 1/10 OFF-ROAD - LIGHTWEIGHT - TITAN
- 108605 FLAT SET-UP BOARD FOR 1/10 OFF-ROAD - LIGHTWEIGHT - BLACK
- 108901 HUDY SET-UP STATION FOR 1/10 OFF-ROAD CARS
- 108960 ALU NUT FOR 1/10 OFF-ROAD SET-UP SYSTEM (4)
- 109801 HUDY ALU TRAY FOR 1/10 OFF-ROAD DIFF & SHOCKS
- 109840 HUDY ALU TRAY FOR 1/10 OFF-ROAD DIFF ASSEMBLY
- 109860 HUDY ALU TRAY FOR SET-UP SYSTEM

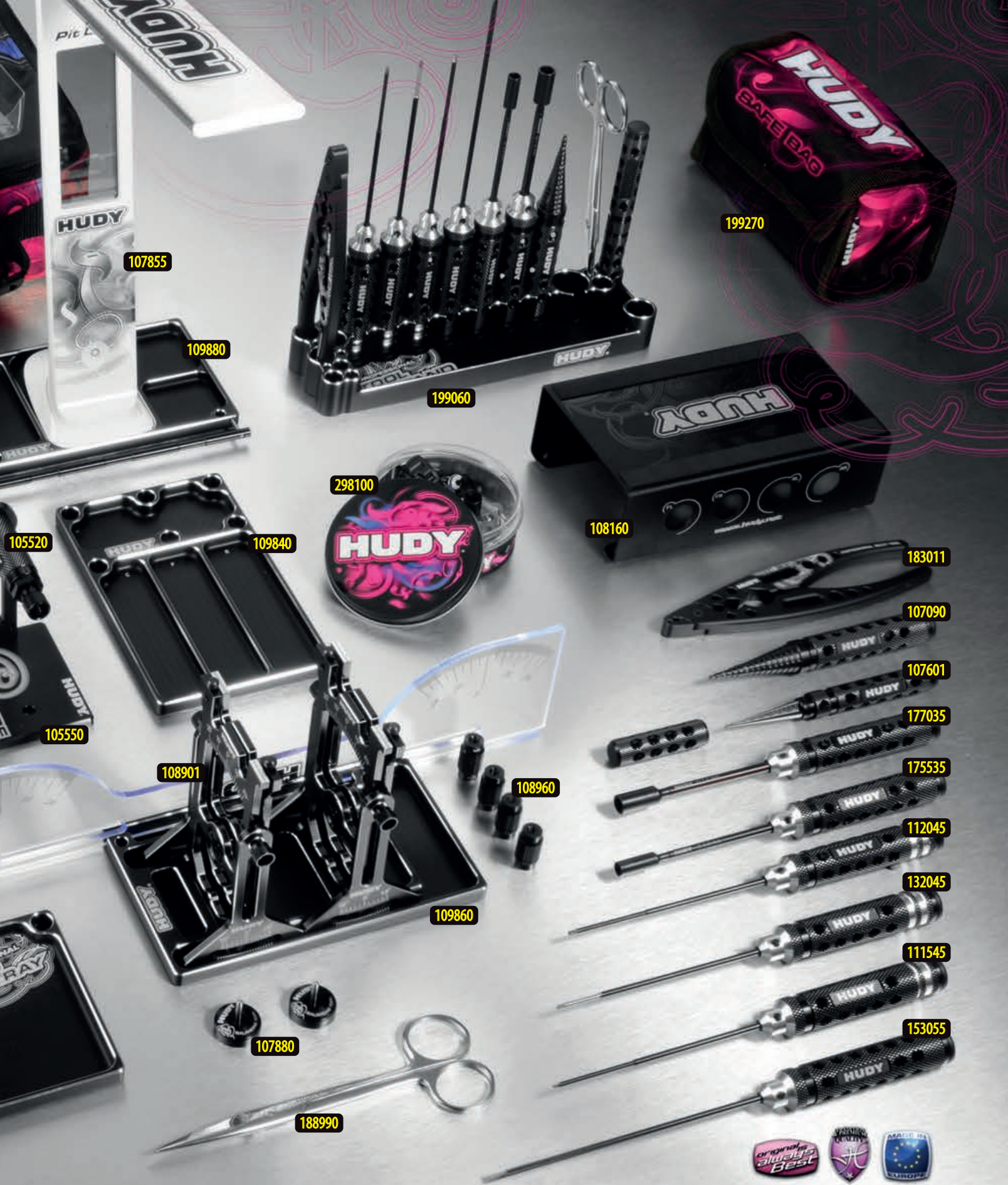

109880 HUDY ALU TRAY FOR ACCESSORIES & PIT LED
 111545 LIMITED EDITION - ALLEN WRENCH # 1.5MM
 112045 LIMITED EDITION - ALLEN WRENCH # 2.0MM
 132045 LIMITED EDITION - ALLEN WRENCH + BALL REPL. TIP # 2.0MM
 153055 LIMITED EDITION - SLOTTED SCREWDRIVER # 3.0MM - LONG
 175535 LIMITED EDITION - SOCKET DRIVER # 5.5MM
 177035 LIMITED EDITION - SOCKET DRIVER # 7.0MM
 181030 HUDY SPRING STEEL TURNBUCKLE WRENCH 3 MM
 181090 HUDY SPECIAL TOOL FOR TURNBUCKLES & NUTS
 183011 HUDY PROFESSIONAL MULTI TOOL

188990 HUDY PROFESSIONAL BODY SCISSORS
 199060 HUDY ALU TOOL STAND
 199183 HUDY CAR BAG - 1/10 OFF-ROAD
 199270 HUDY LIPO SAFETY BAG
 298100 HUDY TIN ROUND BOX 80X30MM
 293100 HUDY ALU RC FAN 30MM - BOTTOM MOUNT 2 HOLE
 293101 HUDY ALU RC FAN 30MM - SIDE MOUNT 2 HOLE
 293110 HUDY BRUSHLESS RC FAN 30MM - WITH EXTERNAL SOLDERING TABS
 293112 HUDY BRUSHLESS RC FAN 30MM - WITH INTERNAL SOLDERING TABS

For more information about tools, set-up equipment and accessories suitable for your car please visit:

www.hudy.net



www.teamxray.com

XRAY EUROPE

XRAY, K VÝSTAVISKU 6992, 91101 TRENCIN, SLOVAKIA, EUROPE
PHONE: +421-32-740 11 00, FAX: +421-32-740 11 09, info@teamxray.com

XRAY USA

RC AMERICA, 2030 Century Center Blvd #15, Irving, TX 75062, USA
PHONE: 214-744-2400, FAX: 214-744-2401, xray@rcamerica.com

