

SET-UP SHEET

X4'25 SET-UP SHEET VER.1 ©XRAY

XRAY X4'25

RACE	Basic US Set-Up For Black CARPET			
TRACK	ProlevelRC			
NAME	Drew Ellis	DATE		
QUAL POSITION	FINAL POSITION	BEST LAPTIME	LAPS	TIME
		/sec	/	

TRACK				
TRACK SURFACE	<input checked="" type="checkbox"/> CARPET	<input type="checkbox"/> ASPHALT		
TRACK LAYOUT	<input type="checkbox"/> TECHNICAL	<input checked="" type="checkbox"/> MIXED	<input type="checkbox"/> FAST	
TRACTION	<input type="checkbox"/> LOW	<input type="checkbox"/> MEDIUM	<input checked="" type="checkbox"/> HIGH	

FRONT		TRANSMISSION		REAR	
GEAR DIFF OIL	/cSt	<input checked="" type="checkbox"/> FRONT SOLID AXLE	GEAR DIFF OIL	8K	/cSt
PINION	29 /T	SPUR GEAR	110 /T	FINAL DRIVE RATIO	

FRONT		SHOCKS		REAR	
2.5-2.8		XRAY SPRINGS		2.6	
350		OIL /cSt		350	
0		REBOUND %		0	
<input type="checkbox"/> YES	<input checked="" type="checkbox"/> NO	FOAM INSERTS		<input type="checkbox"/> YES	<input checked="" type="checkbox"/> NO

<input checked="" type="checkbox"/> 4 HOLES	<input checked="" type="checkbox"/> 1.1mm	1.1mm	<input checked="" type="checkbox"/> 4 HOLES
<input type="checkbox"/> PSS	<input type="checkbox"/> 1.2mm	1.2mm	<input type="checkbox"/> PSS
SHOCK LENGTH		7.0 /mm	7.0 /mm

1.3	THICKNESS/mm	ANTI-ROLL BAR	THICKNESS/mm	1.2
-----	--------------	---------------	--------------	-----

Gravity RC Type C		TIRES		Gravity RC Type C	
SXT 3.0		ADDITIVE		SXT 3.0	
5min		ADDITIVE TIMING		5min	
		WIPE OFF TIME			
Timing:	Temp.:	TIRE WARMERS	Timing:	Temp.:	

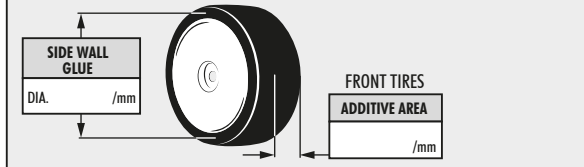

TOTAL WEIGHT	1320 /g	WEIGHT BALANCE	FRONT 50 %	REAR 50 %
--------------	---------	----------------	------------	-----------

MOTOR	Motiv	TIMING	
ESC	HW	BATTERIES	
BODY	Twister	WING	Twister

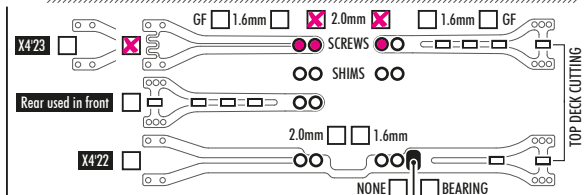
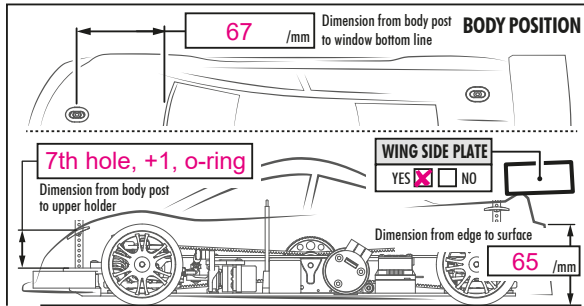

COMMENTS	

