

1/10 ELECTRIC FORMULA

XTRAY X1

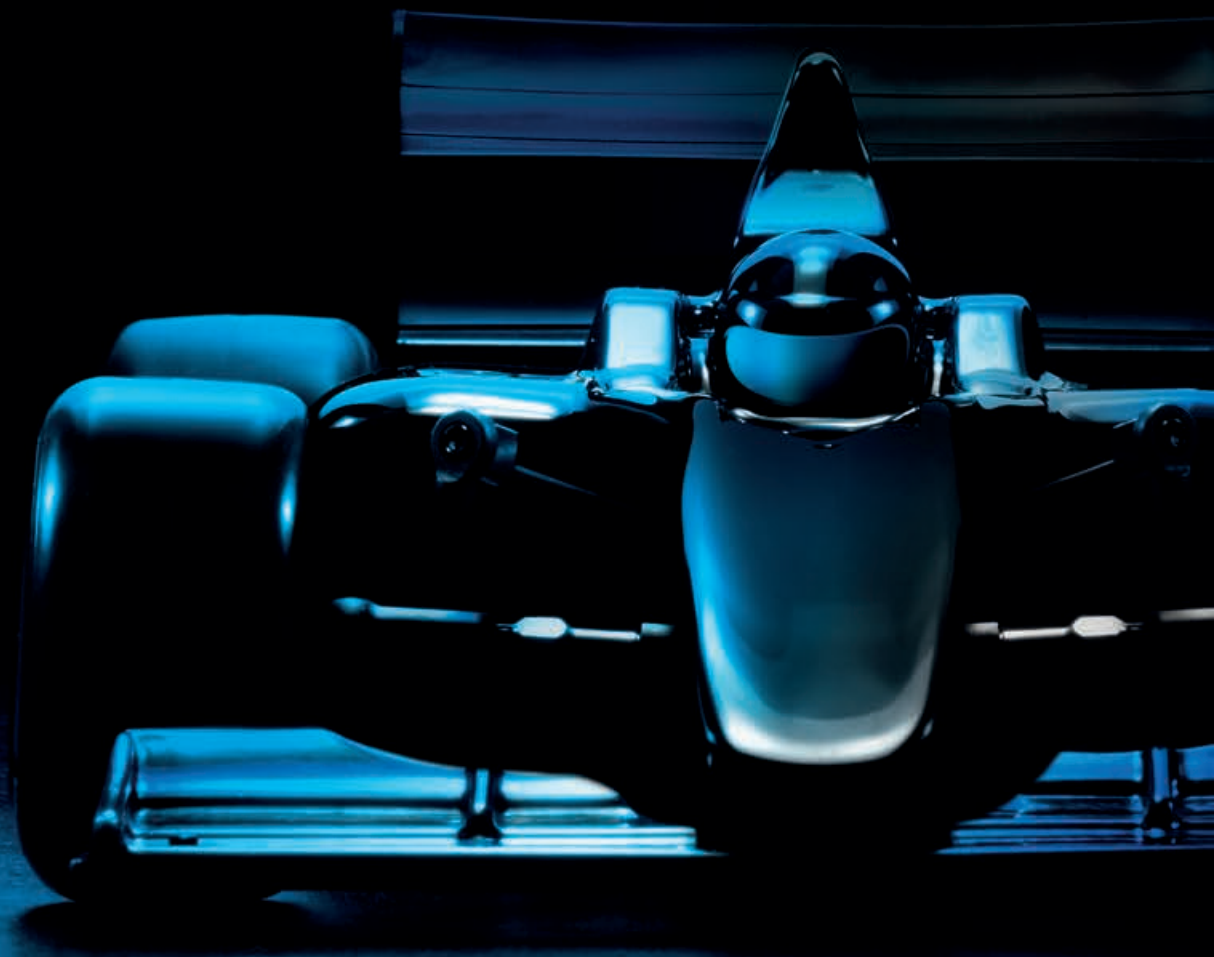

INSTRUCTION MANUAL
FOR X1'25 EDITION

BEFORE YOU START

This is a high-competition, high-quality RC car intended for persons aged 16 years and older with previous experience building and operating RC model racing cars. This is NOT a toy; it is a precision racing model. This model racing car is NOT intended for use by beginners, inexperienced customers, or by children without direct supervision of a responsible, knowledgeable adult. If you DO NOT fulfill these requirements, please return the kit in unused and unassembled form back to the shop where you have purchased it.

Before building and operating your XRAY, **YOU MUST** read through all of the operating instructions and instruction manual and fully understand them to get the maximum enjoyment and prevent unnecessary damage.

CUSTOMER SUPPORT

We have made every effort to make these instructions as easy to understand as possible. However, if you have any difficulties, problems, or questions, please DO NOT hesitate to contact the XRAY support team at info@teamxray.com. Also, please visit our Web site at www.teamxray.com to find the latest updates, set-up information, option parts, and many other goodies. We pride ourselves on taking excellent care of our customers.

You can join thousands of XRAY fans and enthusiasts in our online community at: www.teamxray.com

Read carefully and fully understand the instructions before beginning assembly.

Make sure you review this entire manual, download and use set-up book from the web, and examine all details carefully. If for some reason you decide this is NOT what you wanted or expected, **DO NOT continue any further**. Your hobby dealer can NOT accept your kit for return or exchange after it has been partially or fully assembled.

Contents of the box may differ from pictures. In line with our policy of continuous product development, the exact specifications of the kit may vary without prior notice.

XRAY Europe

K Vystavisku 6992
91101 Trenčín
Slovakia, EUROPE
Phone: 421-32-7401100
Fax: 421-32-7401109
E-mail: info@teamxray.com

XRAY USA

RC America, 2030 Century Center Blvd #15 Irving,
TX 75062
USA
Phone: (214) 744-2400
Fax: (214) 744-2401
E-mail: xray@rcamerica.com

FAILURE TO FOLLOW THESE INSTRUCTIONS WILL BE CONSIDERED AS ABUSE AND/OR NEGLIGENCE.

SAFETY PRECAUTIONS

Contains:

LEAD (CAS 7439-92-1) ANTIMONY (CAS 7440-36-0)

WARNING: This product contains a chemical known to the state of California to cause cancer and birth defects or other reproductive harm.

CAUTION: CANCER HAZARD

Contains lead, a listed carcinogen. Lead is harmful if ingested. Wash thoroughly after using. DO NOT use product while eating, drinking or using tobacco products. May cause chronic effects to gastrointestinal tract, CNS, kidneys, and blood. **MAY CAUSE BIRTH DEFECTS.**

When building, using and/or operating this model always wear protective glasses and gloves.

Take appropriate safety precautions prior to operating this model. You are responsible for this model's assembly and safe operation! Please read the instruction manual before building and operating this model and follow all safety precautions. Always keep the instruction manual at hand for quick reference, even after completing the assembly. Use only genuine and original

authentic XRAY parts for maximum performance. Using any third party parts on this model will void warranty immediately.

Improper operation may cause personal and/or property damage. XRAY and its distributors have no control over damage resulting from shipping, improper construction, or improper usage. XRAY assumes and accepts no responsibility for personal and/or property damages resulting from the use of improper building materials, equipment and operations. By purchasing any item produced by XRAY, the buyer expressly warrants that he/she is in compliance with all applicable federal, state and local laws and regulation regarding the purchase, ownership and use of the item. The buyer expressly agrees to indemnify and hold harmless XRAY for all claims resulting directly or indirectly from the purchase, ownership or use of the product. By the act of assembling or operating this product, the user accepts all resulting liability. If the buyer is NOT prepared to accept this liability, then he/she should return this kit in new, unassembled, and unused condition to the place of purchase.



IMPORTANT NOTES – GENERAL

- This product is NOT suitable for children under 16 years of age without the direct supervision of a responsible and knowledgeable adult.
- Carefully read all manufacturers warnings and cautions for any parts used in the construction and use of your model.
- Assemble this kit only in places away from the reach of very small children.
- First-time builders and users should seek advice from people who have building experience in order to assemble the model correctly and to allow the model to reach its performance potential.
- Exercise care when using tools and sharp instruments.
- Take care when building, as some parts may have sharp edges.
- Keep small parts out of reach of small children. Children must NOT be allowed to put any parts in their mouth, or pull vinyl bag over their head.
- Read and follow instructions supplied with paints and/or cement, if used (NOT included in kit).
- Immediately after using your model, DO NOT touch equipment on the model such as the motor and speed controller, because they generate high temperatures. You may seriously burn yourself seriously touching them.
- Follow the operating instructions for the radio equipment at all times.
- DO NOT put fingers or any objects inside rotating and moving parts, as this may cause damage or serious injury as your finger, hair, clothes, etc. may get caught.
- Be sure that your operating frequency is clear before turning on or running your model, and never share the same frequency with somebody else at the same time. Ensure that others are aware of the operating frequency you are using and when you are using it.
- Use a transmitter designed for ground use with RC cars. Make sure that no one else is using the same frequency as yours in your operating area. Using the same frequency at the same time, whether it is driving, flying or sailing, can cause loss of control of the RC model, resulting in a serious accident.
- Always turn on your transmitter before you turn on the receiver in the car. Always turn off the receiver before turning your transmitter off.
- Keep the wheels of the model off the ground when checking the operation of the radio equipment.
- Disconnect the battery pack before storing your model.
- When learning to operate your model, go to an area that has no obstacles that can damage your model if your model suffers a collision.
- Remove any sand, mud, dirt, grass or water before putting your model away.
- If the model behaves strangely, immediately stop the model, check and clear the problem.
- To prevent any serious personal injury and/or damage to property, be responsible when operating all remote controlled models.
- The model car is NOT intended for use on public places and roads or areas where its operation can conflict with or disrupt pedestrian or vehicular traffic.
- Because the model car is controlled by radio, it is subject to radio interference from many sources that are beyond your control. Since radio interference can cause momentary loss of control, always allow a safety margin in all directions around the model in order to prevent collisions.
- DO NOT use your model:
 - Near real cars, animals, or people that are unaware that an RC car is being driven.
 - In places where children and people gather
 - In residential districts and parks
 - In limited indoor spaces
 - In wet conditions
 - In the street
 - In areas where loud noises can disturb others, such as hospitals and residential areas.
 - At night or anytime your line of sight to the model may be obstructed or impaired in any way.

To prevent any serious personal injury and/or damage to property, please be responsible when operating all remote controlled models.

XRAY

IMPORTANT NOTES – ELECTRICAL

- Insulate any exposed electrical wiring (using heat shrink tubing or electrical tape) to prevent dangerous short circuits. Take maximum care in wiring, connecting and insulating cables. Make sure cables are always connected securely. Check connectors for if they become loose. And if so, reconnect them securely. Never use RC models with damaged wires. A damaged wire is extremely dangerous, and can cause short-circuits resulting in fire. Please have wires repaired at your local hobby shop.
- Low battery power will result in loss of control. Loss of control can occur due to a weak battery in either the transmitter or the receiver. Weak running battery may also result in an out of control car if your car's receiver power is supplied by the running battery. Stop operation immediately if the car starts to slow down.
- When NOT using RC model, always disconnect and remove battery.
- DO NOT disassemble battery or cut battery cables. If the running battery short-circuits, approximately 300W of electricity can be discharged, leading to fire or burns. Never disassemble battery or cut battery cables.
- Use a recommended charger for the receiver and transmitter batteries and follow the instructions correctly. Over-charging, incorrect charging, or using inferior chargers can

cause the batteries to become dangerously hot. Recharge battery when necessary. Continual recharging may damage battery and, in the worst case, could build up heat leading to fire. If battery becomes extremely hot during recharging, please ask your local hobby shop for check and/or repair and/or replacement.

- Regularly check the charger for potential hazards such as damage to the cable, plug, casing or other defects. Ensure that any damage is rectified before using the charger again. Modifying the charger may cause short-circuit or overcharging leading to a serious accident. Therefore DO NOT modify the charger.
- Always unplug charger when recharging is finished.
- DO NOT recharge battery while battery is still warm. After use, battery retains heat. Wait until it cools down before charging.
- DO NOT allow any metal part to short circuit the receiver batteries or other electrical/electronic device on the model.
- Immediately stop running if your RC model gets wet as may cause short circuit.
- Please dispose of batteries responsibly. Never put batteries into fire.

R/C & BUILDING TIPS

- Make sure all fasteners are properly tightened. Check them periodically.
- Make sure that chassis screws DO NOT protrude from the chassis.
- For the best performance, it is very important that great care is taken to ensure the free movement of all parts.
- Clean all ball-bearings so they move very easily and freely.
- Tap or pre-thread the plastic parts when threading screws.
- Self-tapping screws cut threads into the parts when being tightened. DO NOT use excessive force when tightening the self-tapping screws because you may strip out the thread in the plastic. We recommended you stop tightening a screw when you feel some resistance.

- Ask your local hobby shop for any advice.

Please support your local hobby shop. We at XRAY Model Racing Cars support all local hobby dealers. Therefore we ask you, if at all possible, to purchase XRAY products at your hobby dealer and give them your support like we do.

If you have difficulty finding XRAY products, please check out www.teamxray.com to get advice, or contact us via email at info@teamxray.com, or contact the XRAY distributor in your country.

WARRANTY

XRAY guarantees this model kit to be free from defects in both material and workmanship within 30 days of purchase. The total monetary value under warranty will in no case exceed the cost of the original kit purchased. This warranty DOES NOT cover any components damaged by use or modification or as a result of wear. Part or parts missing from this kit must be reported within 30 days of purchase. No part or parts will be sent under warranty without proof of purchase. Should you find a defective or missing part, contact the local distributor. Service and customer support will be provided through local hobby store where you have purchased the kit, therefore make sure to purchase any XRAY products at your local hobby store. This model racing car is considered to be a high-performance racing vehicle. As such this vehicle will be used in an extreme range of conditions and situations, all which may cause premature wear or failure of any component. XRAY has no control over usage of vehicles once they leave the dealer, therefore XRAY can only offer warranty against all manufacturer's defects in materials, workmanship, and assembly at point of sale and before use. No warranties are expressed or implied that cover damage caused by what is considered normal use, or cover or imply how long any model cars' components or electronic components will last before requiring replacement.

Due to the high performance level of this model car you will need to periodically maintain and replace consumable components. Any and all warranty coverage will NOT cover replacement of any part or component damaged by neglect, abuse, or improper or unreasonable use. This includes but is NOT limited to damage from crashing, chemical and/or water damage, excessive moisture, improper or no maintenance, or user modifications which compromise the

integrity of components. Warranty will NOT cover components that are considered consumable on RC vehicles. XRAY DOES NOT pay nor refund shipping on any component sent to XRAY or its distributors for warranty. XRAY reserves the right to make the final determination of the warranty status of any component or part.

LIMITATIONS OF LIABILITY.

XRAY makes no other warranties expressed or implied. XRAY shall NOT be liable for any loss, injury or damages, whether direct, indirect, special, incidental, or consequential, arising from the use, misuse, or abuse of this product and/or any product or accessory required to operate this product. In no case shall XRAY's liability exceed the monetary value of this product.

Take adequate safety precautions prior to operating this model. You are responsible for this model's assembly and safe operation.

Disregard of the any of the above cautions may lead to accidents, personal injury, or property damage.

XRAY MODEL RACING CARS assumes no responsibility for any injury, damage, or misuse of this product during assembly or operation, nor any addictions that may arise from the use of this product.

All rights reserved.

QUALITY CERTIFICATE

XRAY MODEL RACING CARS uses only the highest quality materials, the best compounds for molded parts and the most sophisticated manufacturing processes of TQM (Total Quality Management). We guarantee that all parts of a newly-purchased kit are manufactured with the highest regard to quality. However, due to the many factors inherent in model racecar

competition, we cannot guarantee any parts once you start racing the car. Products which have been worn out, abused, neglected or improperly operated will NOT be covered under warranty. We wish you enjoyment of this high-quality and high-performance RC car and wish you best success on the track!

In line with our policy of continuous product development, the exact specifications of the kit may vary. In the unlikely event of any problems with your new kit, you should contact the model shop where you purchased it, quoting the part number.

We do reserve all rights to change any specification without prior notice. All rights reserved.

TOOLS REQUIRED

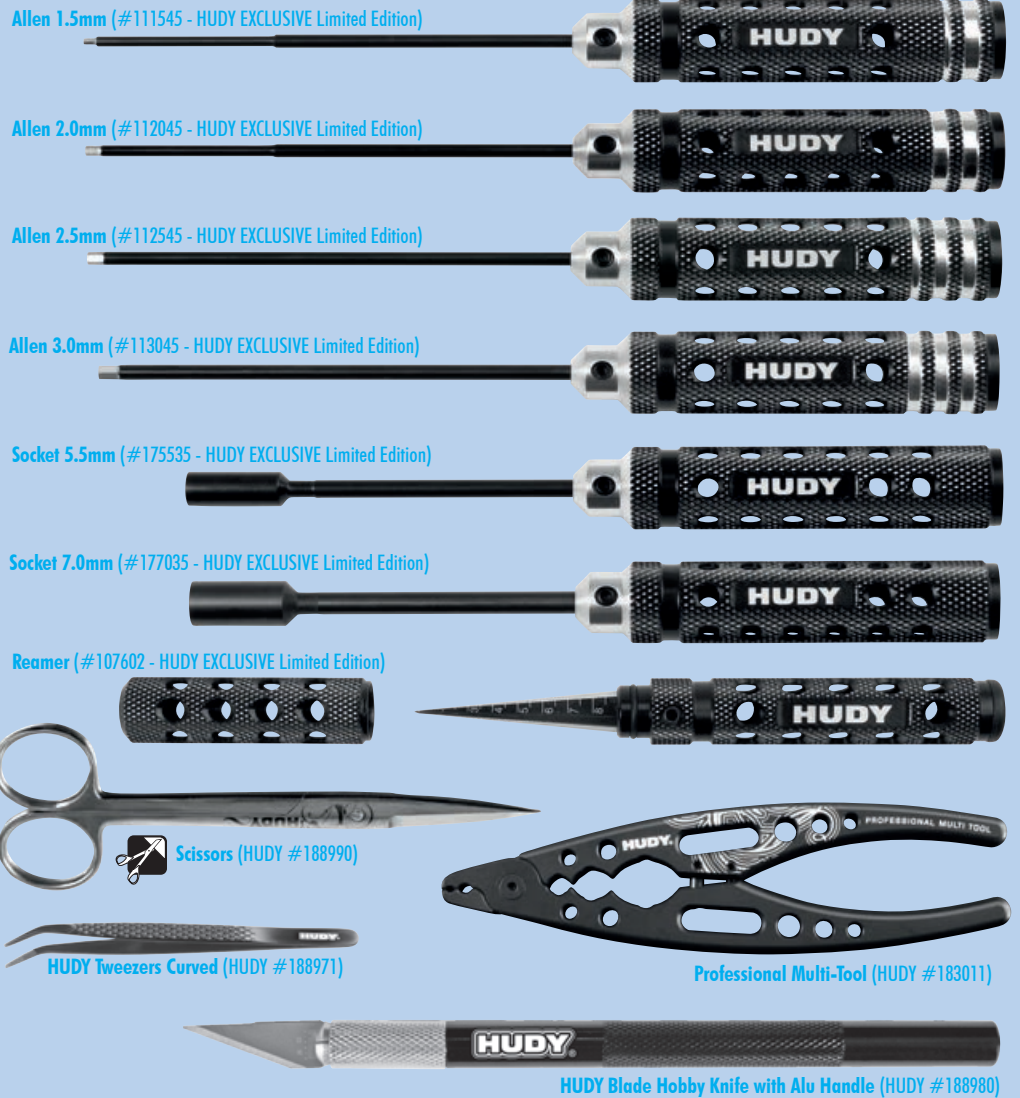

INCLUDED

HUDY
Premium Silicone Oils

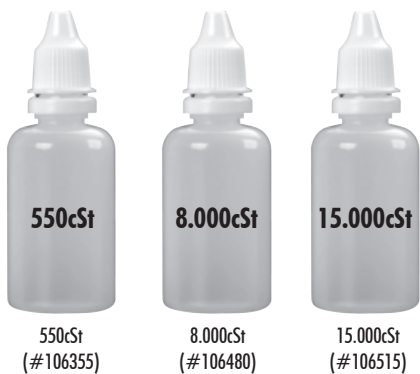

ALSO REQUIRED

| | | | |
|-----------------------------------|--|-------------------------|---|
| <p>Transmitter</p> | <p>Receiver</p> | <p>Speed Controller</p> | <p>Steering Servo</p> |
| <p>Electric Motor</p> | <p>Pinion Gear with Setscrew (#305968 ~ #294160)</p> | <p>LiPo Battery</p> | <p>Battery Charger</p> |
| <p>Bearing Oil (HUDY #106230)</p> | <p>Wheels & Tires & Inserts (HUDY #803072 & #803082)</p> | <p>Lexan™ Paint</p> | <p>Double-sided Tape (HUDY #107875)</p> |

TIP



TIP

Jan Ratheisky
(Factory Driver)

The European Champion and XRAY factory team driver Jan Ratheisky shares his pro tips and tricks.

OPTIONAL



SAMPLE OF OPTIONAL PARTS

| #37XXXX | TYPE1 | OPTION 1 |
|---------|-------|----------|
| #37XXXX | TYPE1 | OPTION 2 |
| #37XXXX | TYPE1 | INCLUDED |
| #37XXXX | TYPE1 | OPTION 3 |

XRAY offers wide range of OPTIONAL tuning parts which are listed in a table like this. Please refer to the exploded view of each main section to verify which part is included in the kit while all other parts are available only as an optional part and must be purchased separately.

COLOR INDICATIONS

At the beginning of each section is an exploded view of the parts to be assembled. There is also a list of all the parts and part numbers that are related to the assembly of that section.

The part descriptions are color-coded to make it easier for you to identify the source of a part. Here are what the different colors mean:

372213

STYLE A - indicates parts that are included in the bag marked for the section.

371201

STYLE B - indicates parts that are included in the box.

374901

STYLE C - indicates parts that are already assembled from previous steps.

379701

STYLE D - indicates parts that are optional.

CARBON PARTS PROTECTION

To protect and seal edges of carbon parts, sand edges smooth and then apply CA glue. Make it: this for chassis edges and countersunk holes.



Apply only a bit of CA glue in the countersunk holes.

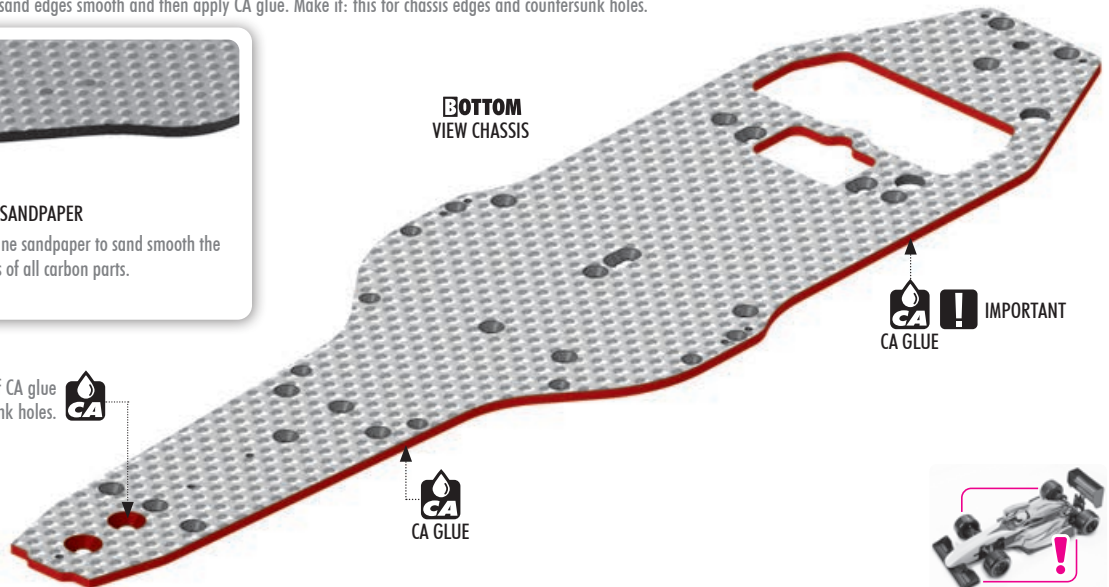

Carbon Fiber Material Quality Assurance

XRAY utilizes the highest quality carbon fiber sheets available on the market, made in the USA. These carbon fiber sheets are pressed, and this production technique may lead to slight variations in the thickness and flatness of each sheet. It is important to note that the carbon manufacturer cannot guarantee perfect uniformity, given the challenges associated with achieving flawless flatness in such thin materials.

When designing our XRAY cars and components, we account for these tolerances regarding thickness and flatness. Minor irregularities in the carbon fiber parts will not compromise the performance of XRAY vehicles once they are assembled with other components. While an individual carbon fiber part may not lay perfectly flat, you can be assured that the assembled vehicle will function as designed and intended.

Additionally, the carbon fiber sheets may exhibit minor irregularities such as small dots, cavities, or scratches, which can occur during the manufacturing process. These characteristics are standard for this type of material and do not detract from the overall quality and performance of XRAY products.

TIP

Some of the larger motors may make slight contact with the chassis. If this occurs, use a Dremel or hand file to gently grind the edge of the chassis where the motor comes into contact.

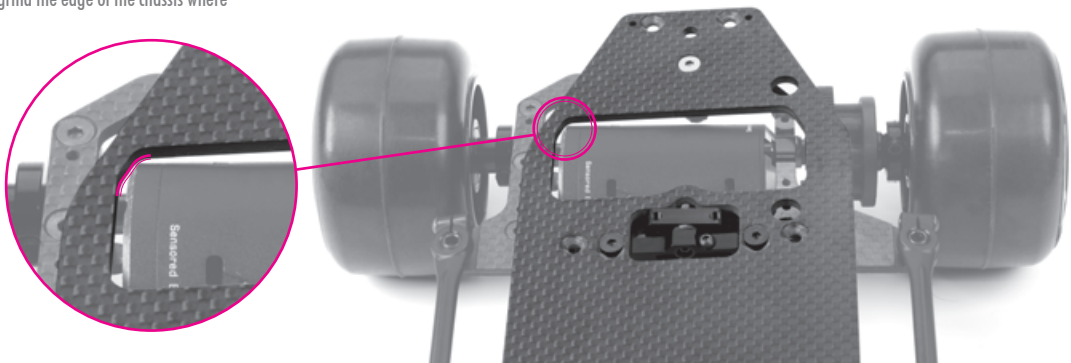

1. FRONT SUSPENSION



#302133-S X4 CFF™ Carbon-Fiber Fusion Upper Arm - Soft - FR/RL
#302143-S X4 CFF™ Carbon-Fiber Fusion Upper Arm - Soft - FL/RR



#302640-T
X4 ADJUSTABLE CAMBER SCREW 14mm M4 L/R - TITANIUM (2)



FRONT COIL SPRINGS

| | | |
|---------|--------------|----------|
| #372174 | C=0.7 SILVER | OPTION |
| #372175 | C=1.1 BLACK | OPTION |
| #372176 | C=1.5 GOLD | OPTION |
| #372177 | C=2.0 SILVER | OPTION |
| #372178 | C=2.5 BLACK | OPTION |
| #372179 | C=3.0 GREY | INCLUDED |
| #372180 | C=3.5 GOLD | OPTION |
| #372181 | C=4.0 SILVER | OPTION |
| #372182 | C=5.0 BLACK | OPTION |
| #372183 | C=5.5 GREY | OPTION |

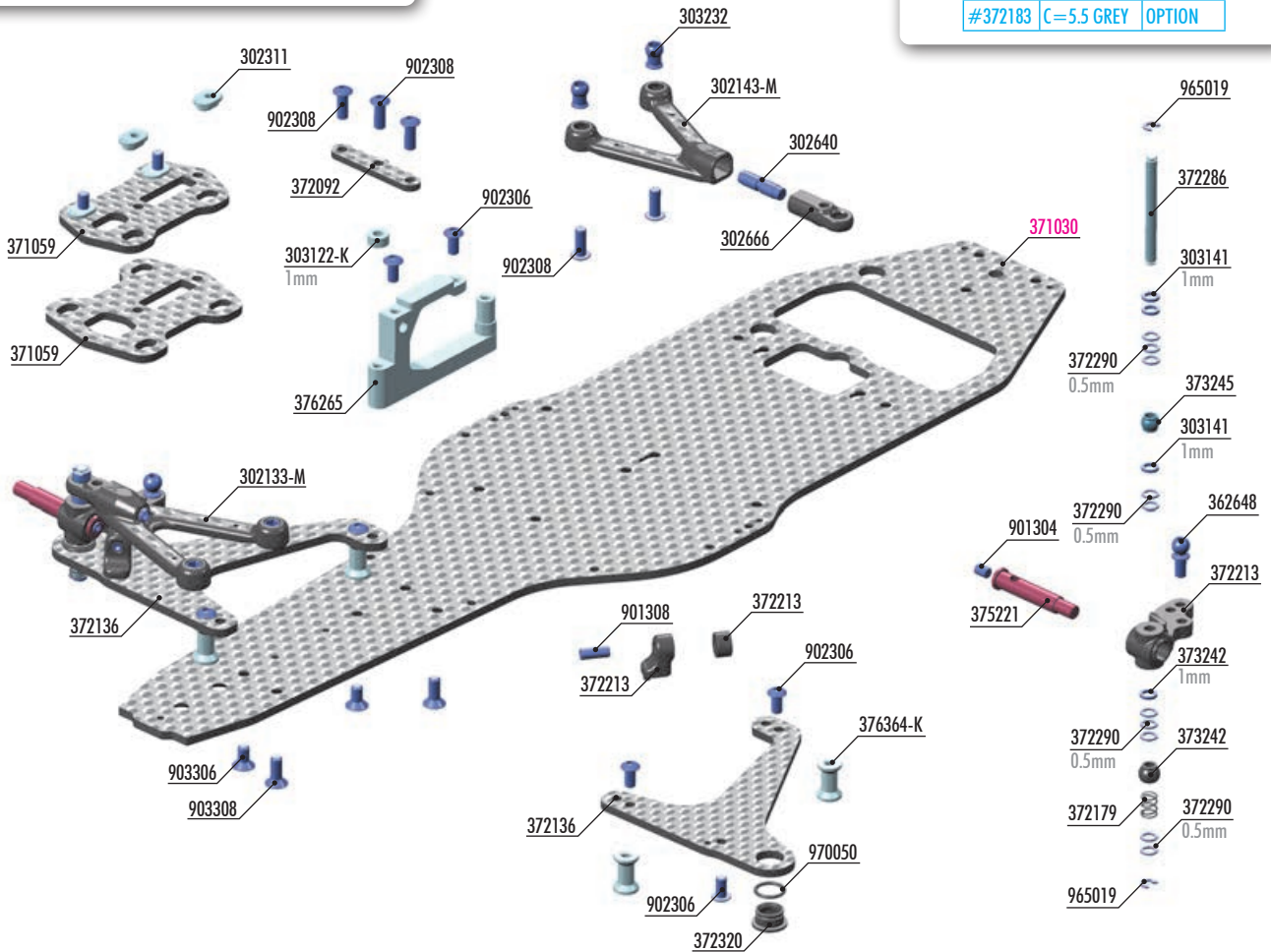

ALU CASTER BUSHINGS

| | | | |
|---------|--------------|--------|----------|
| #302310 | 3.0° / 10.5° | 1 Dot | OPTION |
| #302311 | 4.5° / 9.0° | 2 Dots | INCLUDED |
| #302312 | 6.0° / 7.5° | 3 Dots | OPTION |



#990101
HUDY Titanium Pivot Ball D=4.9 / S=5 / 3mm Hex (2)



BAG

01

| | | | |
|----------|--|----------|--|
| 302133-M | CFF™ CARBON-FIBER FUSION UPPER ARM - MEDIUM - FR/RL | 373242 | COMPOSITE PIVOTBALL UNIVERSAL 6.0mm - SHORT (2) |
| 302143-M | CFF™ CARBON-FIBER FUSION UPPER ARM - MEDIUM - FL/RR | 373245 | X1 UPPER ARM BALL UNIVERSAL 4.9mm - HUDY SPRING STEEL™ (2) |
| 302311 | ALU CASTER BUSHING FRONT 4° / REAR 1.5°/4.5° - 2 DOTS (4) | 375221 | FRONT WHEEL AXLE - HUDY SPRING STEEL™ (2) |
| 302640 | ADJUSTABLE CAMBER SCREW 14mm M4 L/R - HUDY SPRING STEEL™ (2) | 376265 | ALU FRONT TOP DECK MOUNT - SWISS 7075 T6 |
| 302666 | COMPOSITE BALL JOINT 4.9mm F+R - OPEN (2+2) | 376364-K | ALU MOUNT 10.8mm - BLACK (2) |
| 303122-K | ALU SHIM 3x6x1.0mm (10) | 901304 | HEX SCREW SB M3x4 (10) |
| 303141 | ALU SHIM 3x5x1.0mm (10) | 901308 | HEX SCREW SB M3x8 (10) |
| 303232 | UPPER ARM BALL UNIVERSAL 4.9mm - HUDY SPRING STEEL™ (2) | 902306 | HEX SCREW SH M3x6 (10) |
| 362648 | BALL END 4.9mm WITH THREAD 4mm (2) | 902308 | HEX SCREW SH M3x8 (10) |
| 371059 | CARBON ARM MOUNT PLATE - NARROW TRACK-WIDTH | 903306 | HEX SCREW SFH M3x6 (10) |
| 371069 | CARBON ARM MOUNT PLATE - WIDE TRACK-WIDTH | 903308 | HEX SCREW SFH M3x8 (10) |
| 372092 | CARBON FRONT ARM BRACE | 965019 | E-CLIP 1.9 (10) |
| 372136 | CARBON LOWER SUSPENSION ARM | 970050 | O-RING 5x1 (10) |
| 372179 | FRONT COIL SPRING 3.6x6x0.5mm; C=3.0 - GREY (2) | 371030 | X1 CARBON 1-PIECE CHASSIS |
| 372213 | COMPOSITE STEERING BLOCK & BACKSTOPS | | |
| 372286 | KING PIN (2) | | |
| 372290 | ALU SHIM 3.2x4.8x0.5 (4) | | |
| 372320 | COMPOSITE ARM BUSHING (4) | | |

Numbers in parentheses () refer to quantities when purchased separately.

XRAY

1. FRONT SUSPENSION



2x 970050
O 5x1

2x LOWER ARMS



NOTE ORIENTATION !



2x Short composite ball

ASSEMBLED VIEW

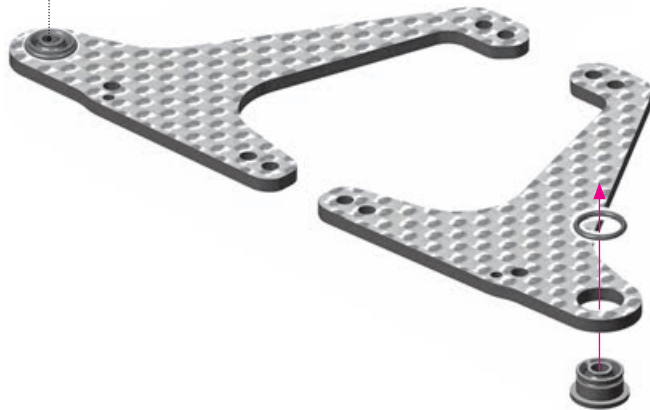

Remove excess material

CUTAWAY VIEW

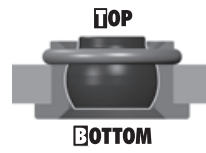

TOP

BOTTOM



2x 901308
SB M3x8

2x

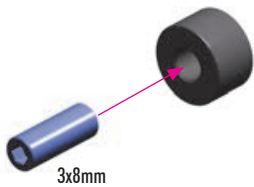

3x8mm

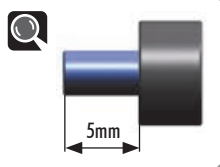

5mm

2x

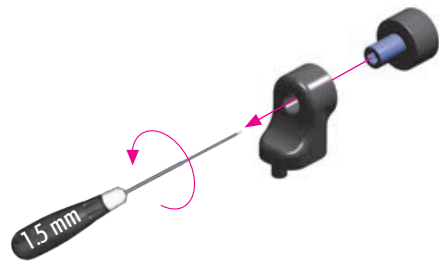

1.5mm



2x 902306
SH M3x6

2x LOWER ARMS

ASSEMBLED VIEW

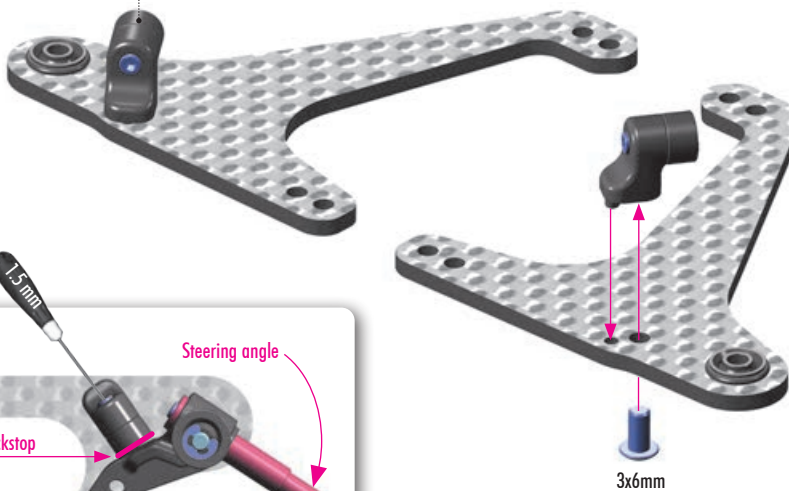

Steering angle

Backstop

3x6mm

The adjustable backstops are used to limit the steering angle. Adjust the backstop with the set-screw to achieve the maximum steering angle needed. Adjust the steering angle on both L & R sides to the same amount.

TIP



Jan Ratheisky
(Factory Driver)

I recommend using 27° of steering angle for most conditions. If you use more, the car stops too much; only on very small & technical tracks does it make sense to use more.

PRO TIP to check the angle: Take a look from the top of the car on full steering. The tire angle should be parallel to the lower wishbone.



1. FRONT SUSPENSION



2x ALTERNATIVE 1

STANDARD TRACK-WIDTH



Standard track-width setting is used for standard F1 front tires such HUDY, RIDE, HOT RACE.

To make sure that you use the correct setting, measure the track-width with the tires; the track-width must be maximum 190mm.

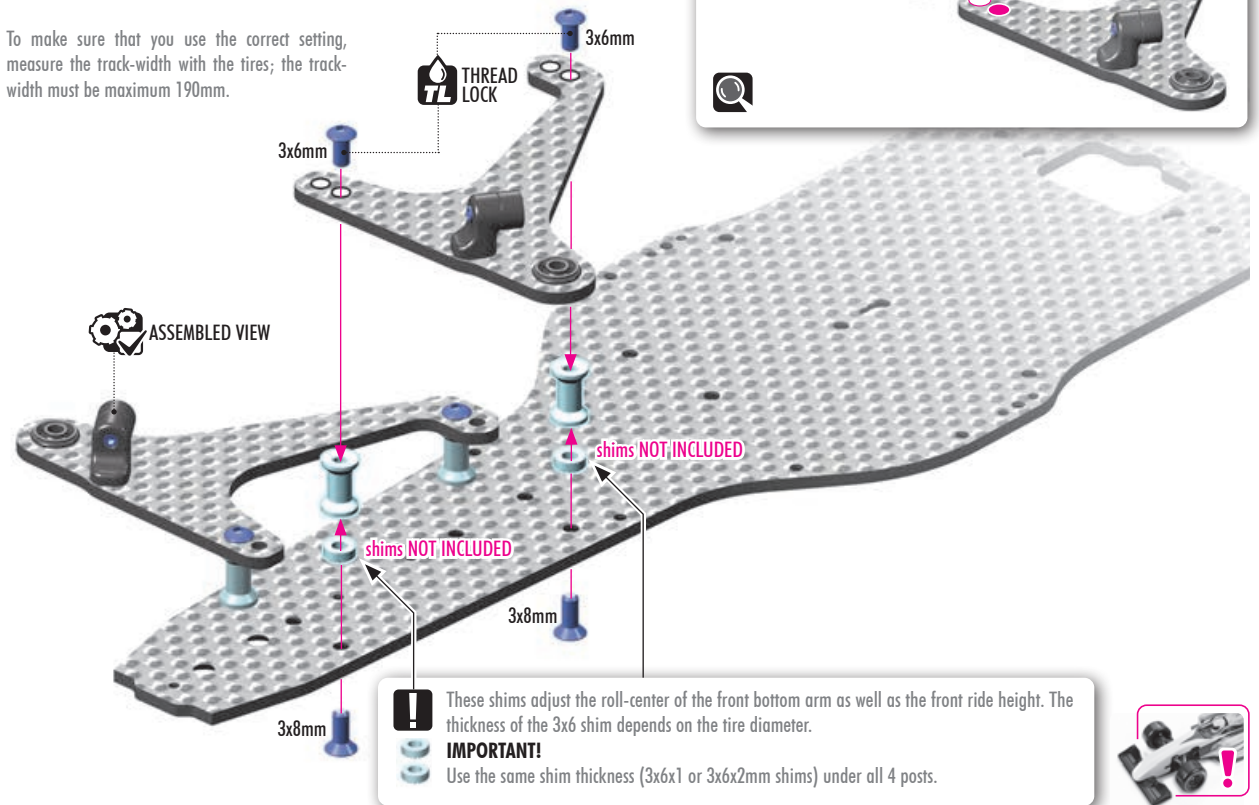

! These shims adjust the roll-center of the front bottom arm as well as the front ride height. The thickness of the 3x6 shim depends on the tire diameter.
IMPORTANT!
 Use the same shim thickness (3x6x1 or 3x6x2mm shims) under all 4 posts.



2x ALTERNATIVE 2

WIDE TRACK-WIDTH

Wide track width setting used for narrow front tires such as Volante or foam tires.

To make sure that you use the correct setting, measure the track-width with the tires; the track-width must be maximum 190mm.

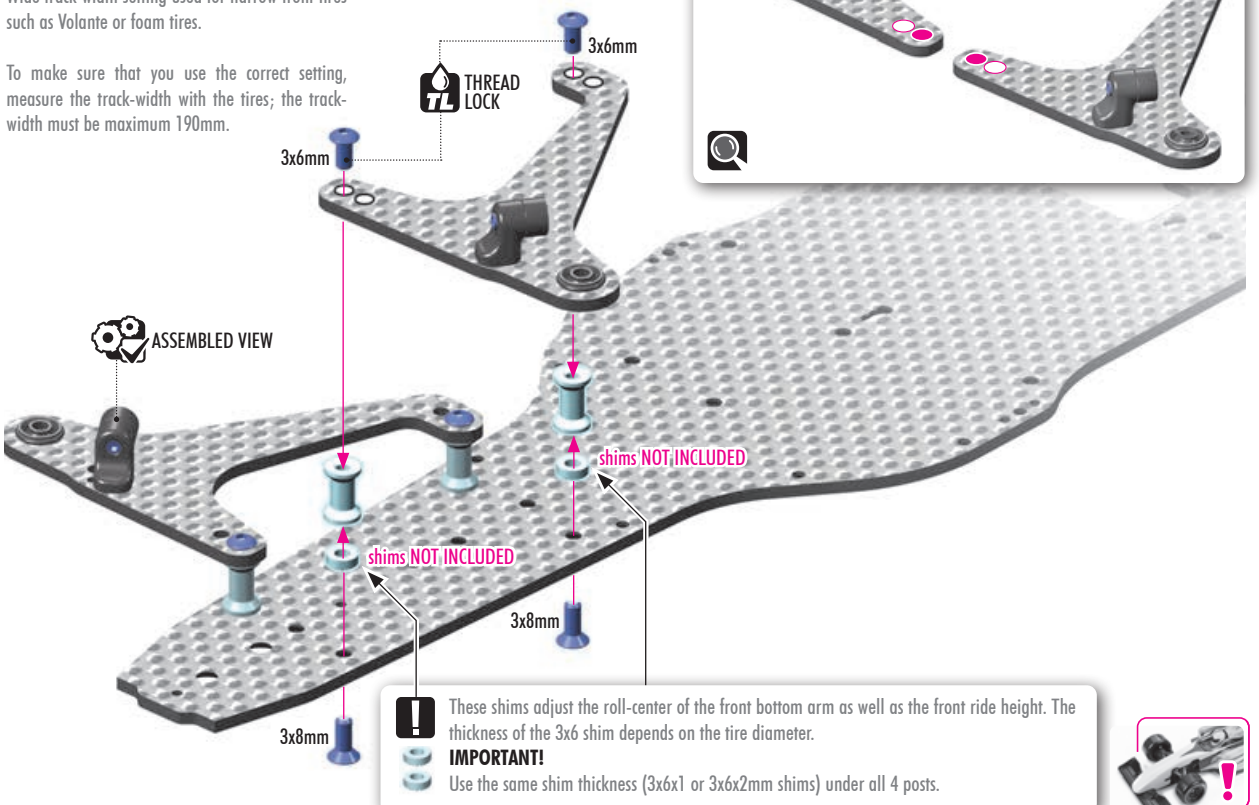

! These shims adjust the roll-center of the front bottom arm as well as the front ride height. The thickness of the 3x6 shim depends on the tire diameter.
IMPORTANT!
 Use the same shim thickness (3x6x1 or 3x6x2mm shims) under all 4 posts.



1. FRONT SUSPENSION



NOTE ORIENTATION FOR ALL PARTS

IMPORTANT
All 4 bushings **MUST** have same orientation.

ALTERNATIVE 1 STANDARD TRACK-WIDTH

✓ **INITIAL SETTING**

Never use alu or titanium screws for the eccentric bushings.

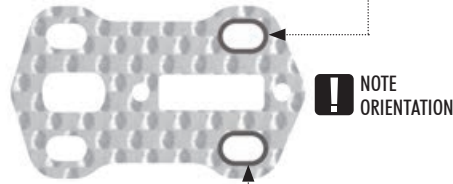
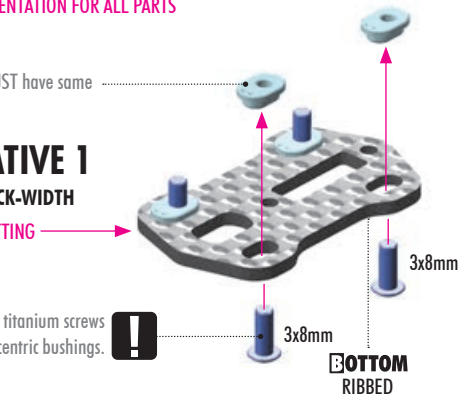

ALTERNATIVE 2 WIDE TRACK-WIDTH

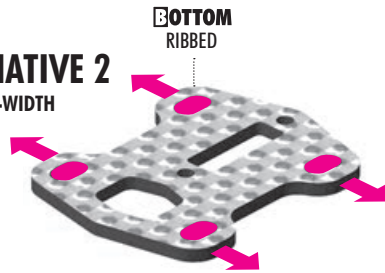

FRONT

- = 3° CASTER
- = 4.5° CASTER
- = 6° CASTER
- = 7.5° CASTER
- = 9° CASTER ✓ **INITIAL SETTING**
- = 10.5° CASTER

REAR

! All four bushings **MUST** have same orientation. These bushings adjust the front **CASTER**:

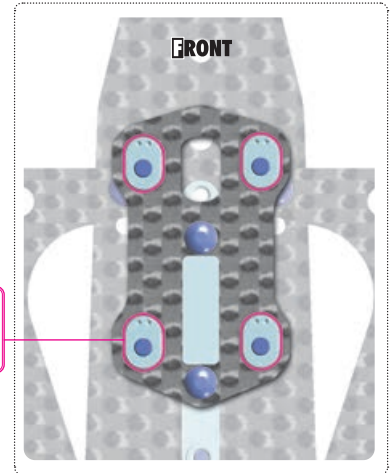

THESE ECCENTRIC BUSHINGS ADJUST THE FRONT **CASTER**.

MORE caster angle = better cornering speed, increased traction rolling. Use on large, open tracks where cornering speed is needed.

LESS caster angle = more reactive steering. Use on technical tracks where a lot of steering response is needed.



OPTION

ALU CASTER BUSHINGS

| OPTION | # | ANGLE | DOTS | STATUS |
|--------|---------|--------------|--------|----------|
| | #302310 | 3.0° / 10.5° | 1 Dot | OPTION |
| | #302311 | 4.5° / 9.0° | 2 Dots | INCLUDED |
| | #302312 | 6.0° / 7.5° | 3 Dots | OPTION |

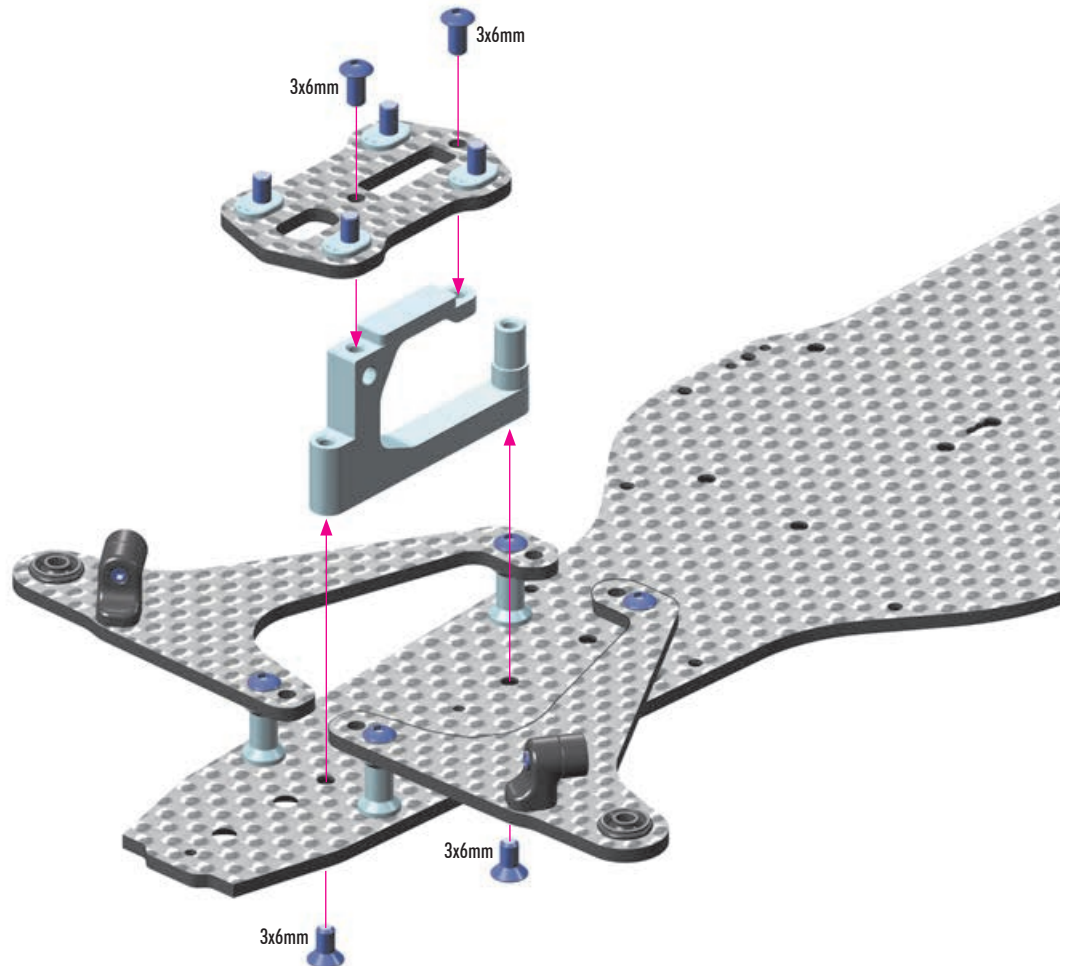

1. FRONT SUSPENSION



3x 902308
SH M3x8



1x 303122-K
SHIM 3x6x1

YOU CAN INSTALL A LOWER ARM BRACE TO INCREASE STEERING RESPONSE.

STEP 1:

To install the carbon brace remove the 3x6mm screws and carbon arm mount plate.

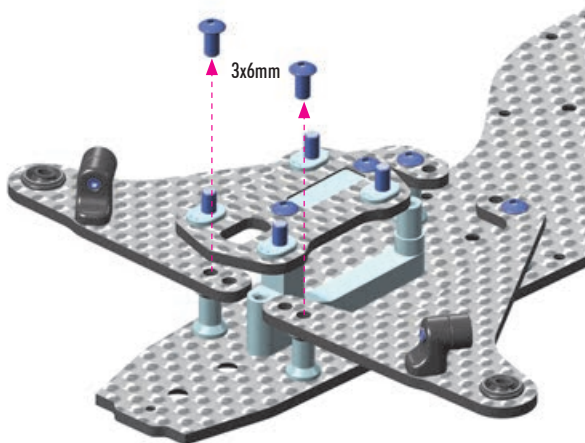

STEP 2:

Install the carbon brace using 3x8mm screws. For stiff setting install also the 1mm shim.

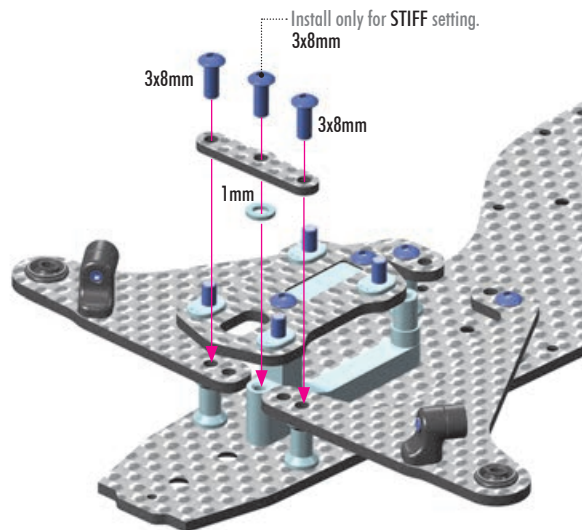

SOFT - WITHOUT THE BRACE

✓ INITIAL SETTING

The car will have less initial steering. Recommended for high- and very-high-traction carpet tracks where the car needs to be easy to drive and less responsive.

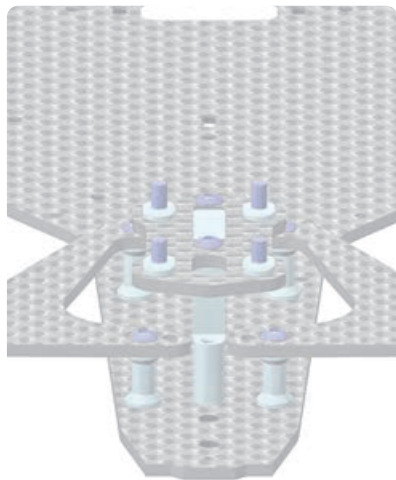

- BRACE (NOT USED)
- SHIM (NOT USED)

MEDIUM - WITH BRACE

Improves in-corner steering but still keeps the car easy to drive. Recommended for medium-high traction carpet tracks and high-traction asphalt tracks.

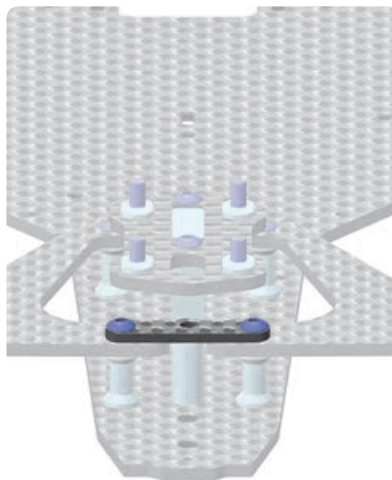

- BRACE USED
- SHIM (NOT USED)

STIFF - WITH BRACE AND CONNECTED TO ALU FRONT STAND

Provides maximum steering response. Recommended for low-medium traction carpet tracks and for all different traction conditions on asphalt tracks.

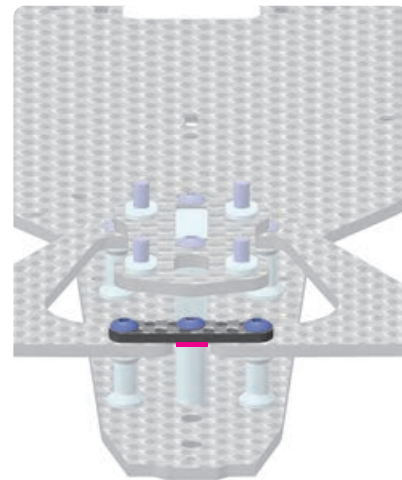

- BRACE USED
- 2mm - SHIM USED

1. FRONT SUSPENSION

2x

Push inside
1
2 Tighten
31mm
Apply Graphite Grease

OPTION #302640-T
X4 ADJUSTABLE CAMBER SCREW
14mm M4 L/R - TITANIUM (2)

2x

2.0mm
FRONT
RIGHT
LEFT
BOTTOM VIEW
REAR
Check arm orientation so that each arm is in the correct location with the markings facing down when installed.
27mm for STANDARD track-width
30mm for WIDE track-width
INITIAL SETTING

! BOTTOM NOTE ORIENTATION

Shiny side Cut out
Ball joint should be aligned in the arm with the machined clearance facing down.

ASSEMBLED VIEW
TIP Install with HUDY Multi Tool.
When ADJUSTING CAMBER, keep the ball joint inline with the upper arm to ensure free movement of the steering block.

OPTION #990101
HUDY Titanium Pivot Ball D=4.9 / S=5 / 3mm Hex (2)

OPTION #302133-S X4 CFF™ Carbon-Fiber Fusion Upper Arm - Soft - FR/RL
#302143-S X4 CFF™ Carbon-Fiber Fusion Upper Arm - Soft - FL/RR

2x 901304 SB M3x4

2x L=R

ASSEMBLED VIEW
BALL 4.9mm
THREAD 4mm
3x4mm
TIGHTEN GENTLY

There are THREE Ackermann positions on the steering block:

! POSITION 3.
If using less bumpsteer shims on the steering plate and the steering linkage is touching the steering block, use 3x6x1mm composite shim (BAG 5).

1mm
05

INITIAL SETTING

1 - easiest to drive
2 - improved steering response
3 - improved overall steering

1. FRONT SUSPENSION

-  8x 303141 SHIM 3x5x1
-  20x 372290 SHIM 3.2x4.8x0.5
-  4x 965019 C1.9

2x 

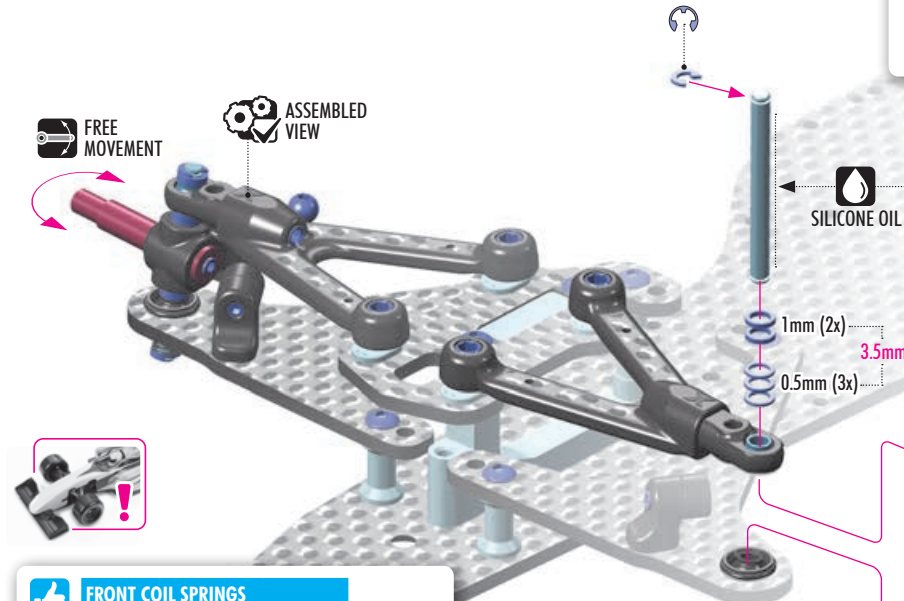

RECOMMENDED HUDY SILICONE OIL

LOW traction & bumpy track:
10K cSt (#106510 HUDY)

HIGH traction & flat track:
30K cSt (#106530 HUDY)

DAMPING
Using thicker oil on the king pin axles makes the car less responsive but easier to drive. Thicker oil increases stability but decreases cornering speed.

The number of the shims affects the front ride height. Determine the proper amount of shimming based on tire diameter.

FRONT COIL SPRINGS

| | | |
|---------|--------------|----------|
| #372174 | C=0.7 SILVER | OPTION |
| #372175 | C=1.1 BLACK | OPTION |
| #372176 | C=1.5 GOLD | OPTION |
| #372177 | C=2.0 SILVER | OPTION |
| #372178 | C=2.5 BLACK | OPTION |
| #372179 | C=3.0 GREY | INCLUDED |
| #372180 | C=3.5 GOLD | OPTION |
| #372181 | C=4.0 SILVER | OPTION |
| #372182 | C=5.0 BLACK | OPTION |
| #372183 | C=5.5 GREY | OPTION |

SOFTER SPRINGS
Makes the car easier to drive over bumps and increases steering as it makes the car roll more, especially in the middle of a corner.

HARDER SPRINGS
Makes the car more responsive and increases initial steering. Recommended for high-traction and flat tracks.

 **TIP**
JAN RATHEISKY (factory driver)

We use different ride heights at indoor and outdoor tracks:

- **INDOOR:** Ride height is as low as the rules allow, usually 4mm.
- **OUTDOOR:** Always run at least 5mm ride height.

Rear ride height should always be 0.1-0.2mm higher than the front.

I recommend changing droop using the upper shims on the kingpin, but note that this also changes the ride height by the same amount. Adding +0.5mm shim means 0.5mm less droop because the spring gets more preload which results in a higher ride height. In that case, you should add the same amount (0.5mm) under the lower wishbone.

DROOP SETTING

INDOOR:
I recommend using a small amount of droop for carpet tracks, somewhere between 0.5-1mm to get the most on-power steering in combination with solid reactive steering.

OUTDOOR:
You should use more droop for asphalt tracks. At least 1mm up to 2mm. The more droop, the more on-power rear traction you get because of weight transfer to the rear. It also helps to get a more smooth-to-drive car at corner entry.

2x 

After assembling the steering block, do the following:

1. Loosen the set-screw slightly.
2. Use your thumb to press down on the top of the kingpin, while using your other fingers to pull up the steering block.
3. Tighten the set-screw.

2. REAR SUSPENSION

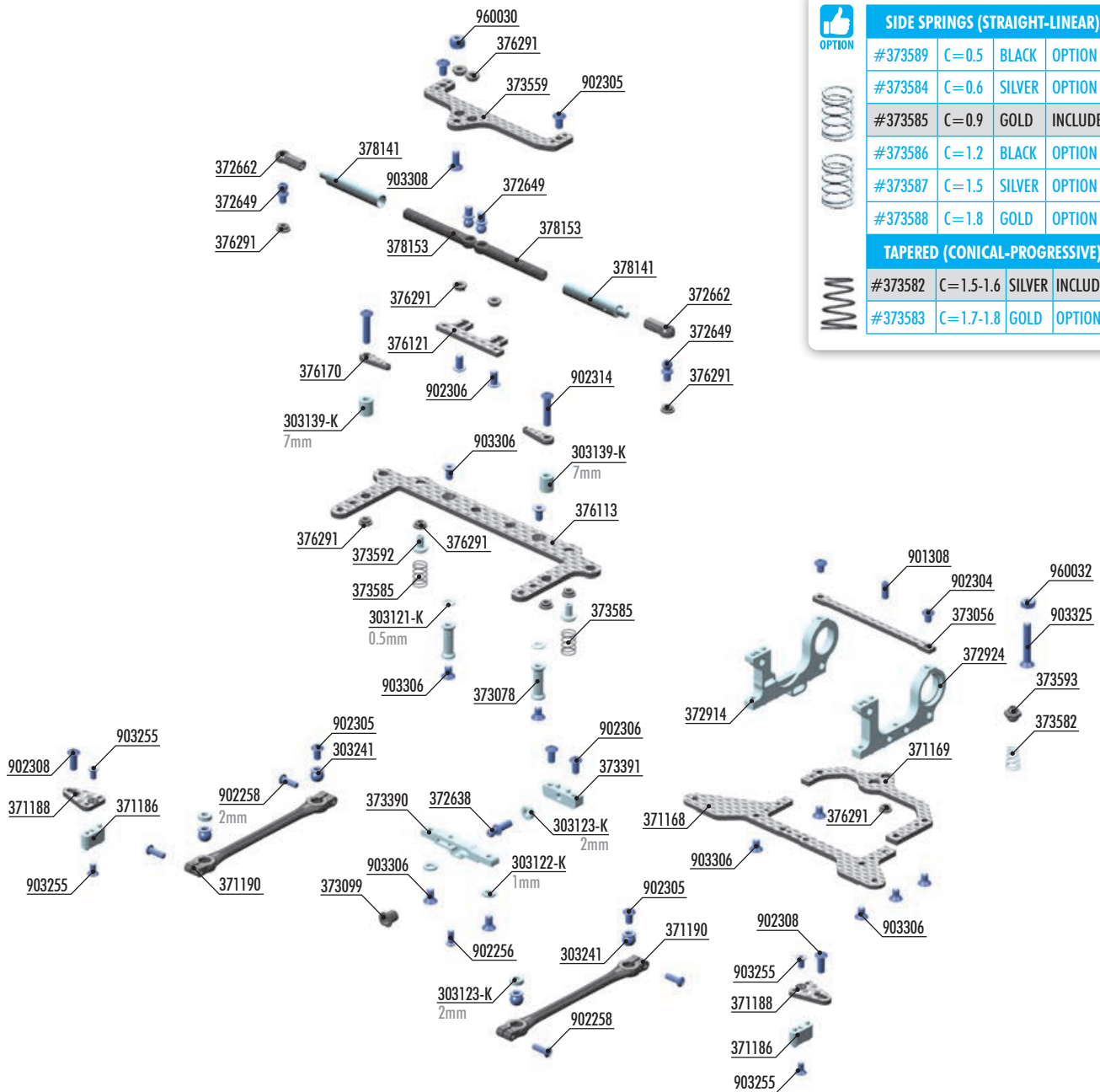

| SIDE SPRINGS (STRAIGHT-LINEAR) | | | |
|--------------------------------|-----------|--------|----------|
| #373589 | C=0.5 | BLACK | OPTION |
| #373584 | C=0.6 | SILVER | OPTION |
| #373585 | C=0.9 | GOLD | INCLUDED |
| #373586 | C=1.2 | BLACK | OPTION |
| #373587 | C=1.5 | SILVER | OPTION |
| #373588 | C=1.8 | GOLD | OPTION |
| TAPERED (CONICAL-PROGRESSIVE) | | | |
| #373582 | C=1.5-1.6 | SILVER | INCLUDED |
| #373583 | C=1.7-1.8 | GOLD | OPTION |

BAG

02

| | | | |
|----------|--|--------|--|
| 303121-K | ALU SHIM 3x6x0.5mm - BLACK (10) | 373593 | COMPOSITE TAPERED/STRAIGHT SPRING HOLDER (2) |
| 303122-K | ALU SHIM 3x6x1.0mm - BLACK (10) | 376113 | CARBON REAR BRACE FOR 1-PIECE CHASSIS |
| 303123-K | ALU SHIM 3x6x2.0mm - BLACK (10) | 376121 | CARBON BATTERY BACKSTOP WITH 3 POSITIONS |
| 303139-K | ALU SHIM 3x6x7.0mm - BLACK (10) | 376170 | CARBON BATTERY CLAMP (2) |
| 303241 | PIVOT BALL UNIVERSAL 5.8mm WITH HEX (4) | 376291 | COMPOSITE M3 SNAP LOCK BUSHING (8) |
| 371168 | CARBON REAR POD LOWER PLATE FOR 1-PIECE CHASSIS - FRONT | 378141 | SIDE LINKAGE TUBE (2) |
| 371169 | CARBON REAR POD LOWER PLATE FOR 1-PIECE CHASSIS - REAR | 378153 | COMPOSITE LINKAGE SHAFT (2) |
| 371186 | ALU HOLDER WITH 2 PINS FOR SIDE LINK CARBON PLATE - BLACK | | |
| 371188 | CARBON PLATE FOR 2 PINS FOR SIDE LINK (2) | 901308 | HEX SCREW SB M3x8 (10) |
| 371190 | COMPOSITE POD LINK (2) | 902256 | HEX SCREW SH M2.5x6 (10) |
| 372638 | HARD STEEL BALL END 3.7mm WITH 8mm THREAD - NICKEL COATED (2) | 902258 | HEX SCREW SH M2.5x8 (10) |
| 372649 | BALL END 4.2mm WITH 4mm THREAD (2) | 902304 | HEX SCREW SH M3x4 (10) |
| 372662 | COMPOSITE BALL-JOINT 4.2mm (4) | 902305 | HEX SCREW SH M3x5 (10) |
| 372914 | ALU REAR BULKHEAD FOR 1-PIECE CHASSIS - MOTOR - RIGHT | 902306 | HEX SCREW SH M3x6 (10) |
| 372924 | ALU REAR BULKHEAD FOR 1-PIECE CHASSIS - LEFT | 902308 | HEX SCREW SH M3x8 (10) |
| 373056 | CARBON REAR BULKHEAD BRACE FOR 1-PIECE CHASSIS | 902314 | HEX SCREW SH M3x14 (10) |
| 373078 | ALU REAR BRACE MOUNT 15.5mm - BLACK (2) | 903255 | HEX SCREW SFH M2.5x5 (10) |
| 373099 | COMPOSITE PIVOT BRACE BUSHING FOR 3.7MM BALL END | 903306 | HEX SCREW SFH M3x6 (10) |
| 373390 | ALU CHASSIS PIVOT HOLDER FOR 1-PIECE CHASSIS - SWISS 7075 T6 | 903308 | HEX SCREW SFH M3x8 (10) |
| 373391 | ALU POD PLATE PIVOT HOLDER FOR 1-PIECE CHASSIS - SWISS 7075 T6 | 903325 | HEX SCREW SFH M3x25 (10) |
| 373559 | CARBON REAR POD UPPER PLATE FOR 1-PIECE CHASSIS | 960030 | NUT M3 (10) |
| 373582 | TAPERED SPRING C=1.5-1.6 - SILVER (2) | 960032 | NUT M3 - BLACK (10) |
| 373585 | SIDE SPRING C=0.9 - GOLD (2) | | |
| 373592 | STEEL SIDE SPRING RETAINER (2) | | |

Numbers in parentheses () refer to quantities when purchased separately.

2. REAR SUSPENSION

NOTE

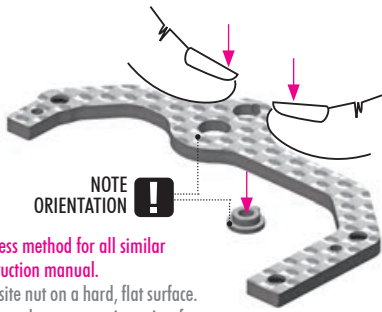

NOTE ORIENTATION

Use the same press method for all similar parts in the instruction manual.
Place the composite nut on a hard, flat surface. Make sure to have the correct orientation for both parts. Press the carbon fiber part straight down onto the nut until seated.



SPECIFIC ORDER

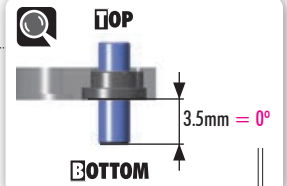
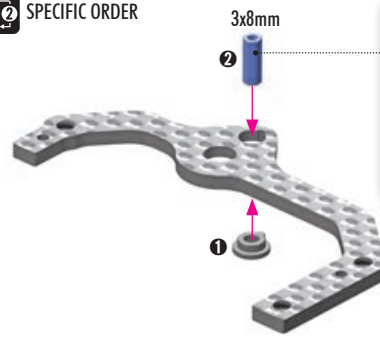

VIDEO TECH TIP



POD ANGLE ADJUSTMENT



POD ANGLE SETTING

The rear pod angle is adjusted using the set screw at the rear of the chassis. A 3.5mm gap between the chassis plate and rear pod means the rear pod is sitting flat. Increasing this gap increases the pod angle, creating a pro-squat effect. Pro-squat decreases on-power steering and increases rear traction.

Reducing the gap below 3.5mm introduces an anti-squat effect, increasing on-power steering while decreasing rear traction.



POD Anti-squat

Anti-squat increases on-power steering and decreases rear traction.



POD Straight INITIAL SETTING



POD Pro-squat

Pro-squat decreases on-power steering and increases rear traction.



2x 902304 SH M3x4



5x 903306 SFH M3x6

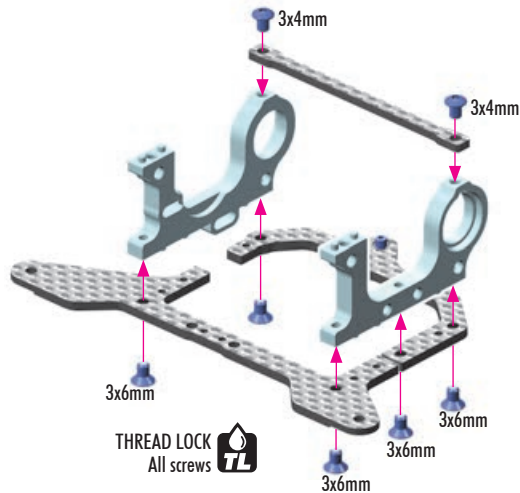

THREAD LOCK
All screws



0x 303123-K SHIM 3x6x2



2x 902306 SH M3x6

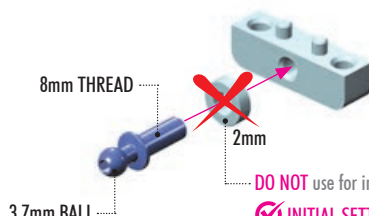

DO NOT use for initial setting.
INITIAL SETTING (0mm shim)

The amount of shims has a direct effect on the pivot mounting position. Please see: PAGE 17

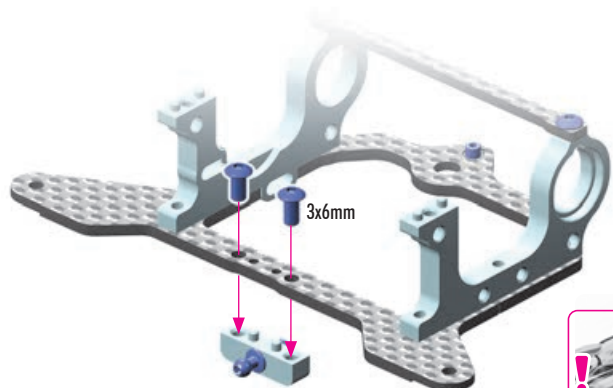

2. REAR SUSPENSION



THERE ARE 2 EASIEST WAY HOW TO MEASURE THE POD ANGLE.

ALTERNATIVE 1

Measure from the the top of the carbon rear lower plate to the top of the chassis.

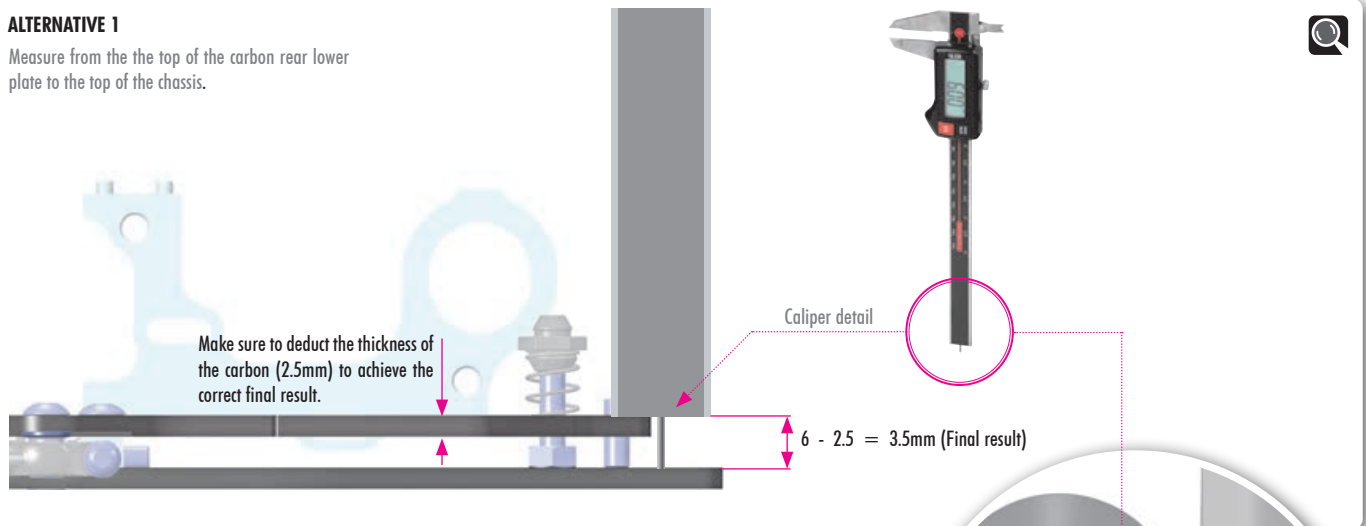

ALTERNATIVE 2

Measure from the bottom of the chassis to the bottom of the carbon rear lower plate.

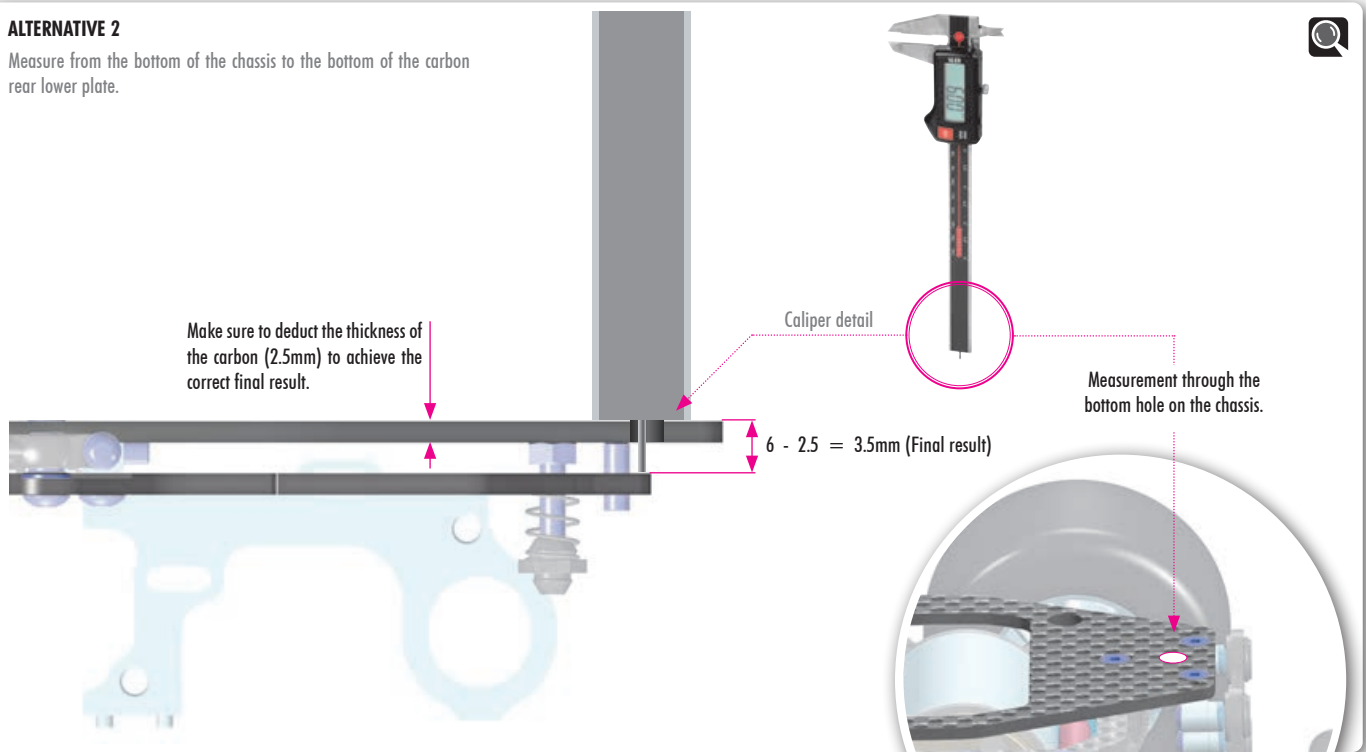

2. REAR SUSPENSION



1x 903325
 SFH M3x25

1x 960032
 N M3

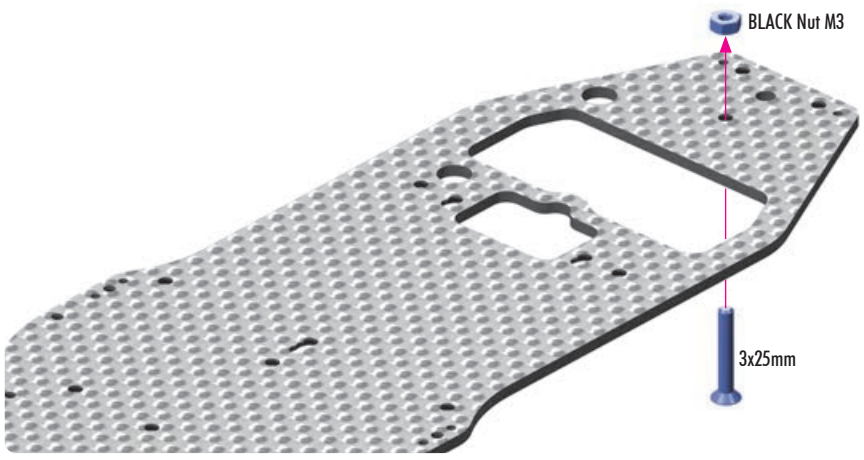

BLACK Nut M3

3x25mm





2x 303122-K
 SHIM 3x6x1

2x 903306
 SFH M3x6

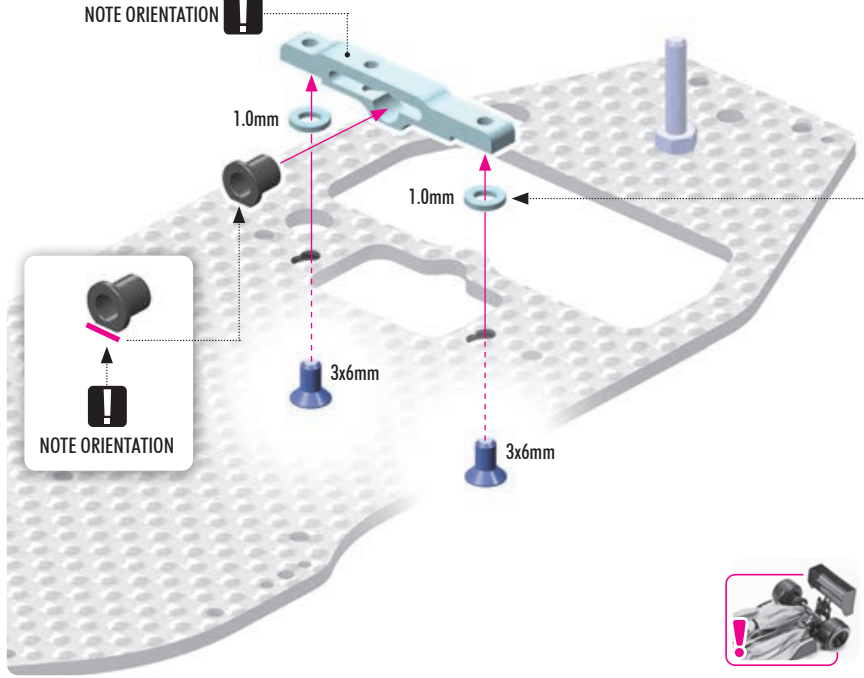

NOTE ORIENTATION 

1.0mm



1.0mm

3x6mm

3x6mm

NOTE ORIENTATION 

ROLL-CENTER

  Use 1mm shim

 **INITIAL SETTING**

NOTE: Using no shims will cause the pivot holder to extend below the chassis plate.



 **INITIAL SETTING**

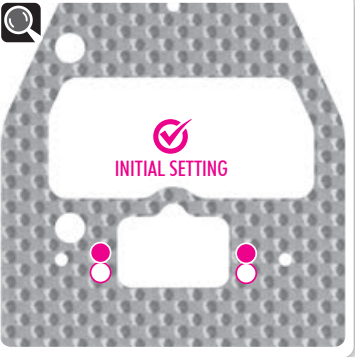





▶ VIDEO TECH TIP



REAR POD & PIVOT BUILD

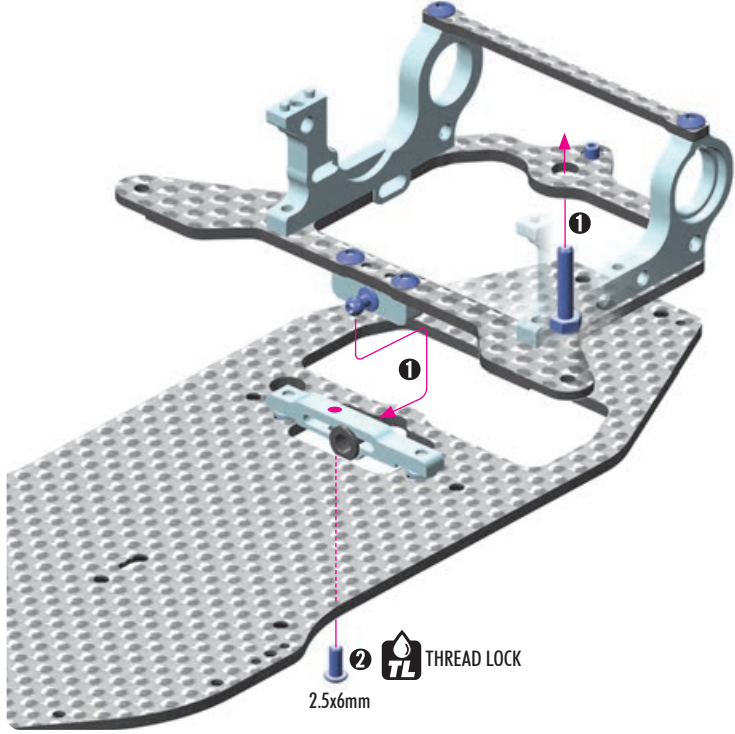

1x 902256
 SH M2.5x6



1

2

2.5x6mm

 **THREAD LOCK**

 **FREE MOVEMENT**

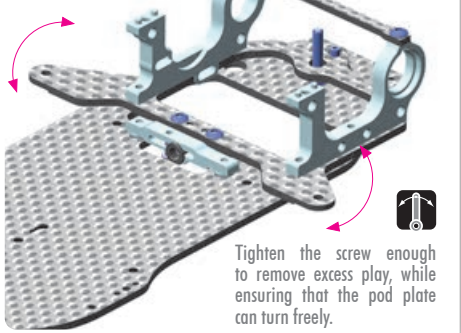

Tighten the screw enough to remove excess play, while ensuring that the pod plate can turn freely.



▶ VIDEO TECH TIP



REAR POD & PIVOT BUILD

2. REAR SUSPENSION



PIVOT MOUNTING ALTERNATIVE

REARWARD:

INITIAL SETTING

Pivot mounted in rear chassis holes with no ball stud shims. Improved rotation from shorter rear pod geometry. Provides most initial steering and rotation; best suited for high traction carpet tracks.

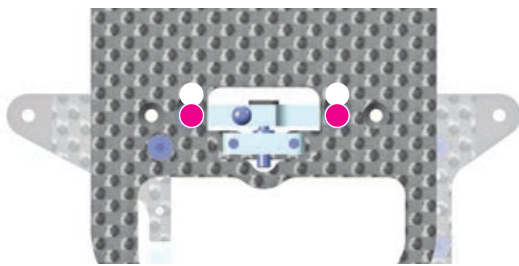
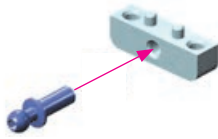

FORWARD:

Pivot mounted in forward chassis holes with 2mm ball stud shims. Creates the most forgiving handling that allows more aggressive driving without fear of losing rear traction.

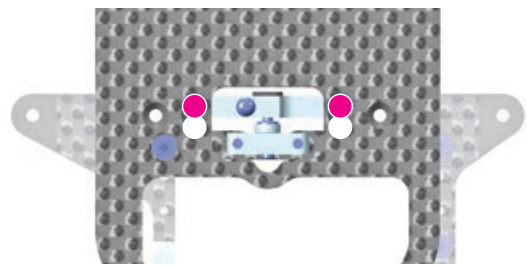
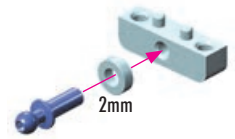

TIP 303123-K shims are NOT INCLUDED in the kit.



ROLL CENTER ADJUSTMENT

The roll center can be adjusted by adding or removing shims from beneath the aluminum pivot mounts.



IMPORTANT

When changing the shims under the chassis pivot holder, the opposite adjustment of the same thickness must be made above the rear pivot holder to keep the pod in the same position.

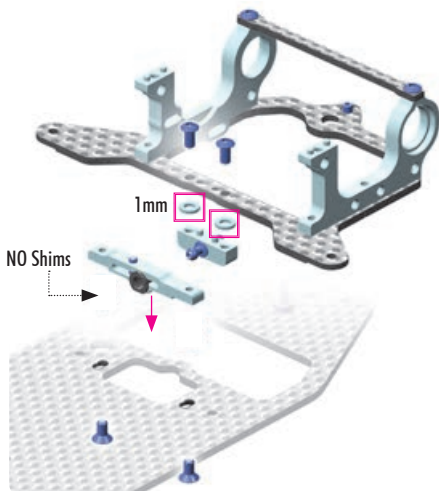

LOWER ROLL CENTER

No shim under alu chassis pivot holder. Creates more traction and increases chassis roll.

Note: The pivot holder will extend below chassis plate in this position.

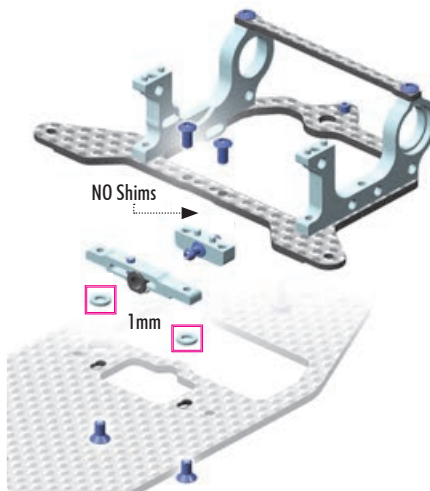

STANDARD ROLL CENTER **INITIAL SETTING**

The standard roll center is the best starting point for most conditions as it gives the most neutral handling. The chassis pivot holder sits in line with the lower chassis plate.

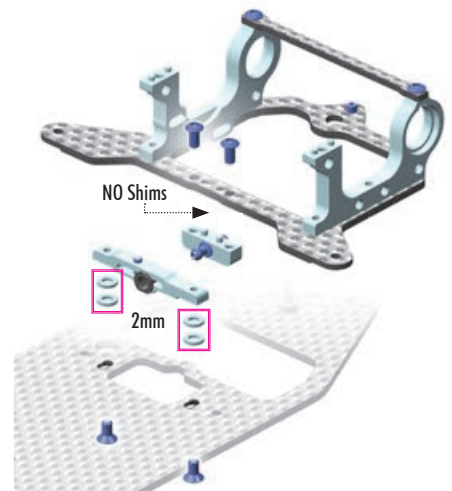

HIGHER ROLL CENTER

Adding shims below the chassis pivot holder increases rotation both on- and off-power.



2x **L=R**

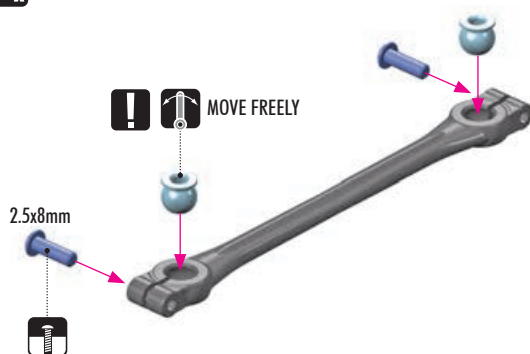

DO NOT tighten fully. Make sure **NOT** to overtighten.

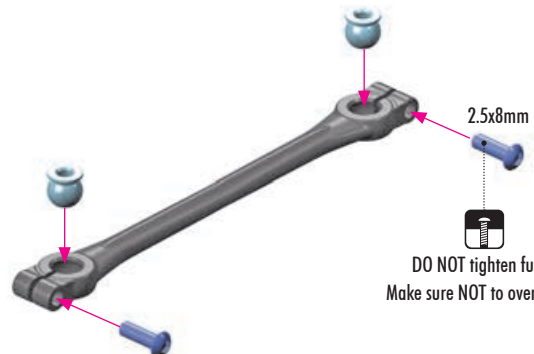

DO NOT tighten fully. Make sure **NOT** to overtighten.

2. REAR SUSPENSION



4x 903255
SFH M2.5x5

2x

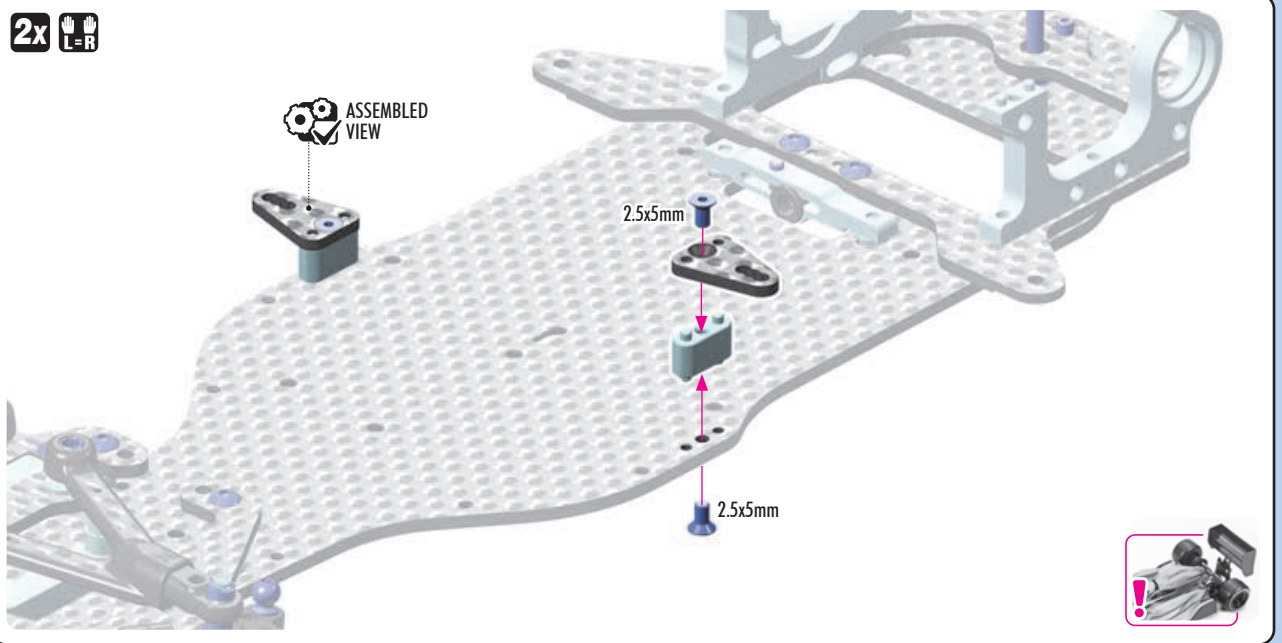

2x 303123-K
SHIM 3x6x2

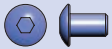

2x 902305
SH M3x5

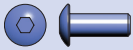

2x 902308
SH M3x8



ASSEMBLED VIEW

Tighten the screws enough to remove excess play, while ensuring that the pod plate can move freely.



Ensure free, smooth movement.

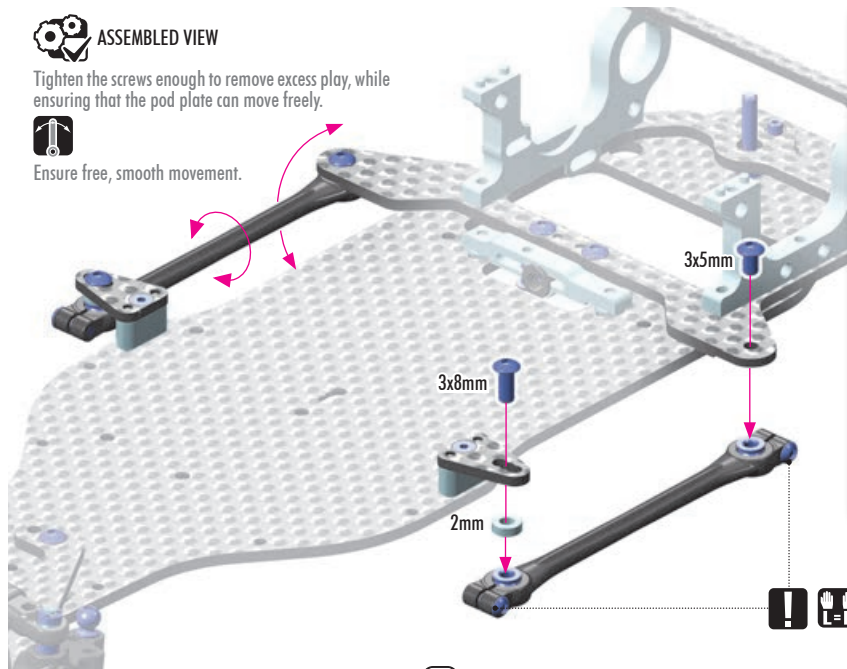

POD LINKAGE POSITION

OUTER POSITION

ANGLED LINK reduces steering, increases stability.

CENTER POSITION

INITIAL SETTING

STRAIGHT LINK easier to drive.

INNER POSITION

ANGLED LINK increases in-corner steering.



NOTE ORIENTATION



POD LINKAGE ANGLE ALTERNATIVE

LESS SHIMS

Raising the side links' **FRONT** pivot point (reducing shims) will further increase in-corner steering, but may be more difficult to drive since the rear inner wheel will lift up more during cornering. 0.5-2.0mm shims may be added for fine tuning.

0mm SHIM

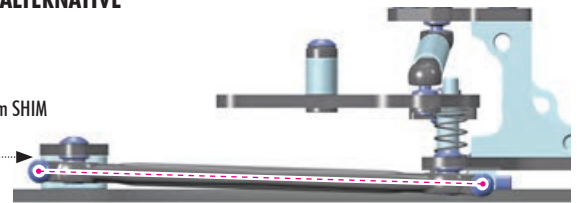

STRAIGHT 2.0mm SHIMS

INITIAL SETTING

Straight link alignment makes the car easier to drive.

2mm SHIM

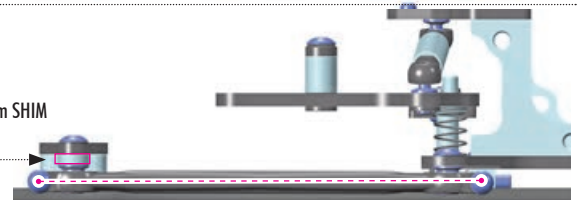

MORE SHIMS

Raising the side links' **REAR** pivot point (adding shims) reduces in-corner steering. This orientation is typically **NOT** used or recommended.

4mm SHIM

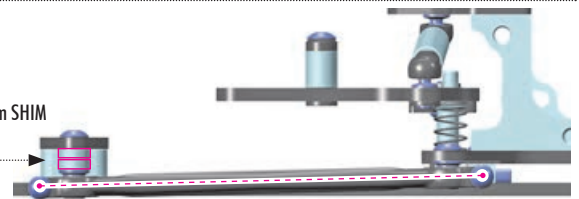

2. REAR SUSPENSION



VIDEO TECH TIP



POD DROOP
ADJUSTMENT

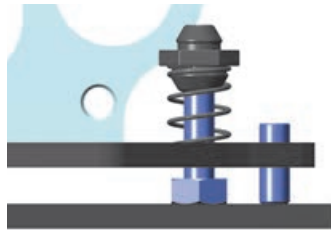
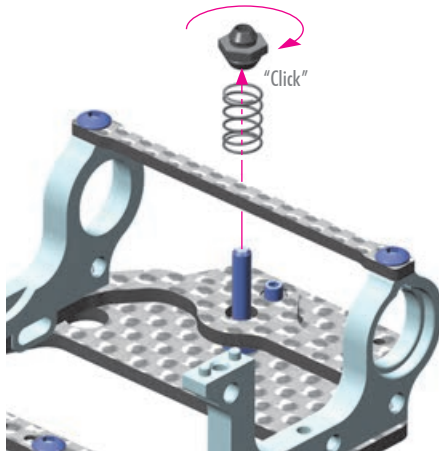

- **TIGHTENING** the rear bump spring increases ride height and reduces droop.
- **LOOSENING** the rear bump spring decreases ride height and increases droop.



REAR RIDE HEIGHT & DROOP SETTING

The rear ride height and rear droop settings are directly related to each other, making it important to use the correct rear axle eccentric holder when adjusting the rear bump spring preload to set the pod droop value.

STIFFER rear bump spring - will be more reactive and will improve on-power steering.

SOFTER rear bump spring - will be less reactive and will reduce on-power steering.

CONICAL-PROGRESSIVE rear bump spring - provides more aggressive handling than a straight-linear rear bump spring. Using a conical-progressive bump spring is usually the faster and most responsive setup.

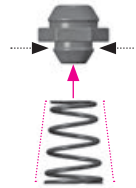

When using a **CONICAL-PROGRESSIVE SPRING**, press the spring onto the smaller diameter end of the spring retainer.



TAPERED (CONICAL-PROGRESSIVE)

| | | | |
|---------|-----------|--------|----------|
| #373582 | C=1.5-1.6 | SILVER | INCLUDED |
| #373583 | C=1.7-1.8 | GOLD | OPTION |

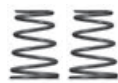

STRAIGHT-LINEAR rear bump spring - provides more neutral handling to make the car easier to drive.

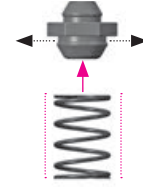

When using a **STRAIGHT-LINEAR SPRING**, press the spring onto the larger diameter end of the spring retainer.



SIDE SPRINGS (STRAIGHT-LINEAR)

| | | | |
|---------|-------|--------|--------|
| #373589 | C=0.5 | BLACK | OPTION |
| #373584 | C=0.6 | SILVER | OPTION |
| #373585 | C=0.9 | GOLD | OPTION |
| #373586 | C=1.2 | BLACK | OPTION |
| #373587 | C=1.5 | SILVER | OPTION |
| #373588 | C=1.8 | GOLD | OPTION |



! Use the same pressing method for all parts in the instruction manual.

Follow PAGE 14 / Step 1

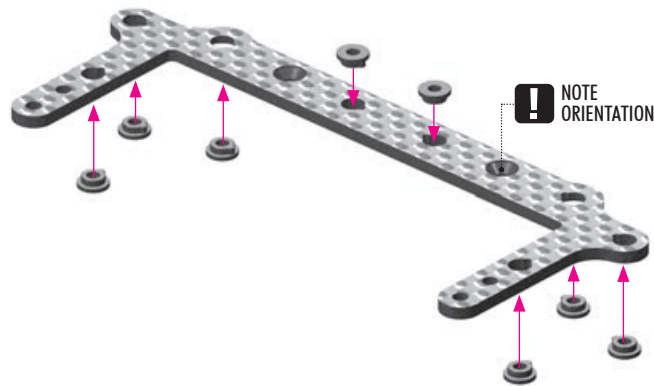

2x **L=R**

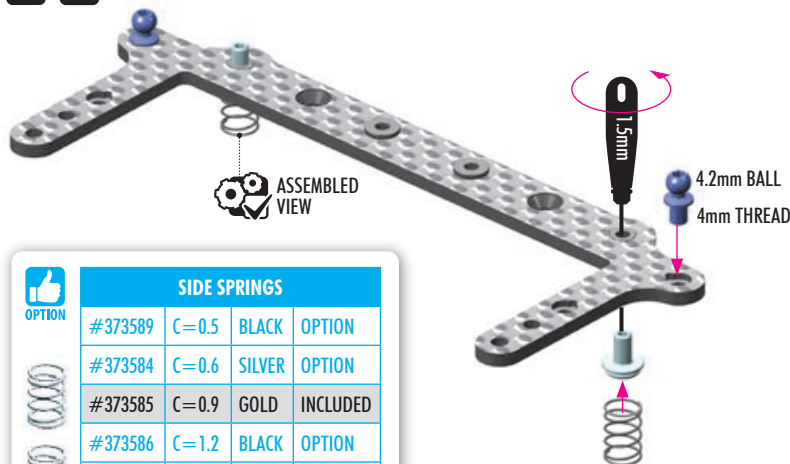

SIDE SPRINGS

| | | | |
|---------|-------|--------|----------|
| #373589 | C=0.5 | BLACK | OPTION |
| #373584 | C=0.6 | SILVER | OPTION |
| #373585 | C=0.9 | GOLD | INCLUDED |
| #373586 | C=1.2 | BLACK | OPTION |
| #373587 | C=1.5 | SILVER | OPTION |
| #373588 | C=1.8 | GOLD | OPTION |

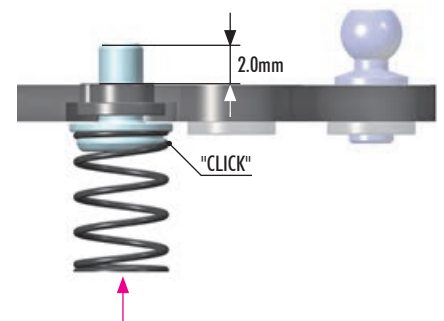

2. REAR SUSPENSION

2x 303139-K
SHIM 3x6x7

2x 902306
SFH M3x6

2x 902314
SH M3x14

2x

IMPORTANT
For BATTERY BACKSTOP ADJUSTMENT
and BATTERY POSITION, see PAGE 41.

IMPORTANT
For BATTERY BACKSTOP
position see PAGE 41.

INITIAL SETTING

IMPORTANT
In case you are using body #379701, you would need to make a small hole on each side to avoid the touching the body with the body holder in case you are using high battery.

4x 903306
SFH M3x6

0x 303121-K
SHIM 3x6x0.5

DO NOT use for initial setting.
INITIAL SETTING (0mm shim)

EXTRA SIDE SPRING PRELOAD ADJUSTMENT

In case the side springs does have too much preload, you can add 0.5 shim under the posts to raise the carbon brace. As a result of raising the carbon plate, side spring preload will be decreases.

IMPORTANT
For BATTERY BACKSTOP
position see PAGE 41.

0.5mm shim

0.5mm
3.0mm

But this will have direct effect on the battery holder and side braces. Therefore in case you raise the carbon brace, you need to add also the same shimming on the battery holder and carbon side braces side braces.

2x 902305
SH M3x5

1x 903308
SFH M3x8

1x 960030
N M3

M3

3x8mm

4mm THREAD
4.2mm BALL

NOTE ORIENTATION

SHORT

LONG

3x5mm

3x5mm

2. REAR SUSPENSION



VIDEO TECH TIP



SIDE TUBES

2x

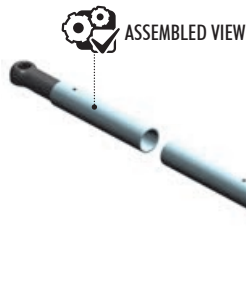

ASSEMBLED VIEW

2x

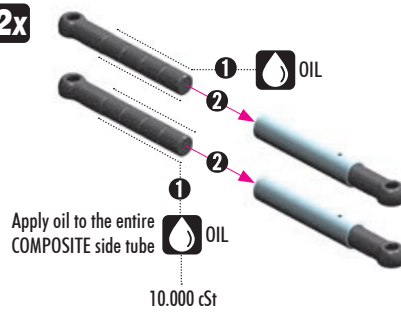

Apply oil to the entire COMPOSITE side tube

10.000 cSt



Apply oil to the entire composite side tube before installing in the aluminum tube. After assembly, check for smooth operation. It is very important to check and re-oil the tubes at least once per race day. Oil thickness can be adjusted depending on the track conditions.



| | |
|-----------------------------|-----------------|
| For HIGH traction | use HARDER oils |
| For LOW traction or ASPHALT | use SOFTER oils |



HUDY OILS 50ml

| OPTION | Oil # | Viscosity |
|--------|---------|-----------|
| | #106450 | 5.000cSt |
| | #106460 | 6.000cSt |
| | #106470 | 7.000cSt |
| | #106480 | 8.000cSt |
| | #106490 | 9.000cSt |
| | #106510 | 10.000cSt |
| | #106492 | 11.000cSt |
| | #106512 | 12.000cSt |
| | #106515 | 15.000cSt |
| | #106520 | 20.000cSt |
| | #106530 | 30.000cSt |

INCLUDED

HARDER OIL - improves stability and makes the car more round and easier to drive.

SOFTER OIL - improves steering.



ASSEMBLED VIEW

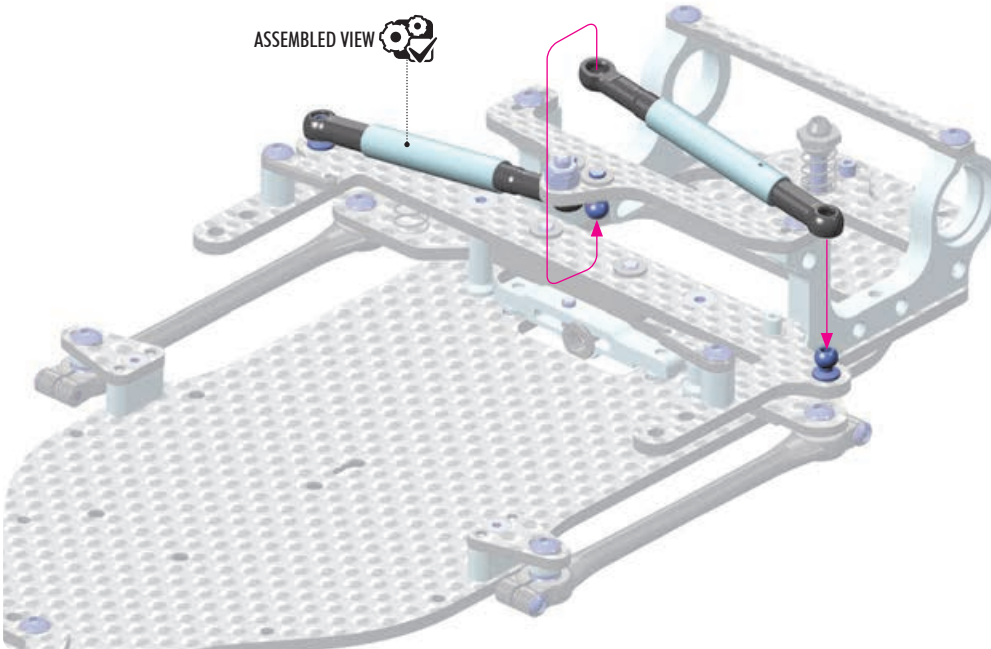

SIDE TUBE ANGLE

Shims of different thickness installed under ball studs are used for different side tube angle adjustment.

The angle of the side tubes has a minor effect on the car's performance.

HIGHER ANGLE:
Stiffer feeling, less roll.
More progressive damping action.

LOWER ANGLE (FLATTER):
Softer feeling, more roll.
More linear damping action.

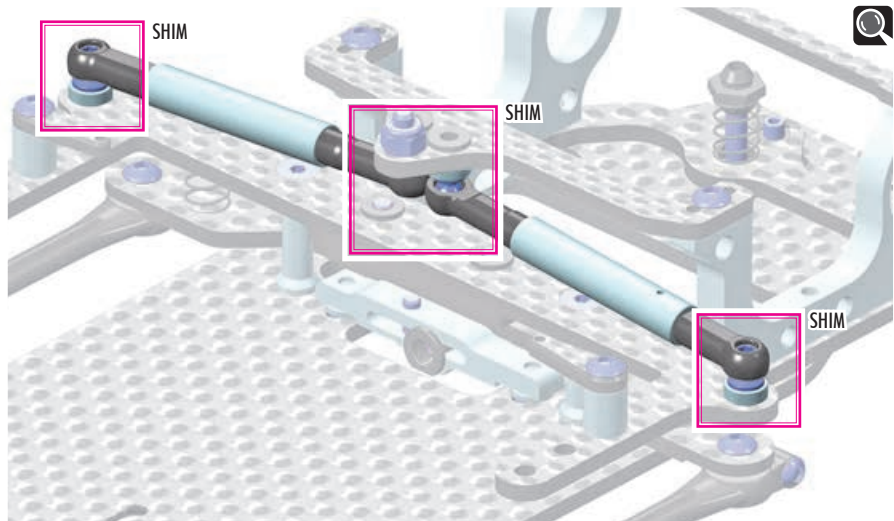

3. GEAR DIFFERENTIAL

GEAR DIFF - SPUR GEARS (64P)

| | | |
|---------|-----|----------|
| #375776 | 76T | OPTION |
| #375780 | 80T | INCLUDED |
| #375784 | 84T | OPTION |
| #375788 | 88T | OPTION |
| #375792 | 92T | OPTION |

#304932
GRAPHITE GEAR DIFF BEVEL & SATELLITE GEARS (2+4)

Use this satellite gear from #374930.

#375014
CARBON REAR GEAR DIFF AXLE SHAFT

#375001
XRAY SOLID AXLE 1/10 FORMULA - SET

BALL DIFF - SPUR GEARS

| | | |
|---------|-----------|--------|
| #375872 | 72T / 64P | OPTION |
| #375875 | 75T / 64P | OPTION |
| #375876 | 76T / 64P | OPTION |
| #375878 | 78T / 64P | OPTION |
| #375880 | 80T / 64P | OPTION |
| #375884 | 84T / 64P | OPTION |
| #375888 | 88T / 64P | OPTION |
| #375892 | 92T / 64P | OPTION |
| #375896 | 96T / 64P | OPTION |

#375010
CARBON REAR AXLE SHAFT

9g lighter for great weight savings and improved acceleration, but more fragile.

#930238
CERAMIC AXIAL THRUSTBEARING F3-8 3x8x3.5mm

#930230
CERAMIC BALL 3.175mm (12)

| | | | | |
|-------------------------|----------|---|--------|--|
| BAG 03 | 304930 | COMPOSITE GEAR DIFF BEVEL & SATELLITE GEARS (2+4) | 375090 | SET OF ALU SHIMS 6.37x8.4mm (0.5mm, 1.0mm, 2.0mm) |
| | 304981 | COMPOSITE GEAR DIFF CROSS PIN WITH HOLE | 375780 | COMPOSITE GEAR DIFF SPUR GEAR - 80T / 64P |
| | 372073 | COMPOSITE ECCENTRIC RIDE HEIGHT ADJUSTER SET (2) | 902256 | HEX SCREW SH M2.5x6 (10) |
| | 374901 | XRAY GEAR DIFFERENTIAL 1/10 FORMULA - SET | 903258 | HEX SCREW SFH M2.5x8 (10) |
| | 374910 | COMPOSITE GEAR DIFFERENTIAL CASE - GRAPHITE | 908258 | HEX SCREW SOCKET HEAD CAP M2.5x8 (10) |
| | 374920 | COMPOSITE GEAR DIFFERENTIAL COVER - GRAPHITE | 964031 | WASHER S 3.5x10x0.2 (10) |
| | 374930 | COMPOSITE GEAR DIFF BEVEL & SATELLITE GEARS (2+4) | 964050 | WASHER S 5x15x0.3 (10) |
| | 374970 | ALU GEAR DIFF SHAFT - SWISS 7075 T6 | 951438 | BALL-BEARING 1/4" x 3/8" x 1/8" FLANGED - STEEL SEALED - OIL (2) |
| | 374990 | DIFF GASKET (4) | 971255 | SILICONE O-RING 25.5x0.7 (10) |
| | 375017-L | X1/X10 REAR GEAR DIFF AXLE SHAFT - LIGHTWEIGHT | 972050 | SILICONE O-RING 5x2 (10) |
| | 375037 | ALU GEAR DIFF REAR WHEEL HUB - SWISS 7075 T6 | 980210 | PIN 2x9.8 (10) |
| | 375046 | ALU REAR WHEEL HUB - LEFT | | |

Numbers in parentheses () refer to quantities when purchased separately.



2. REAR SUSPENSION

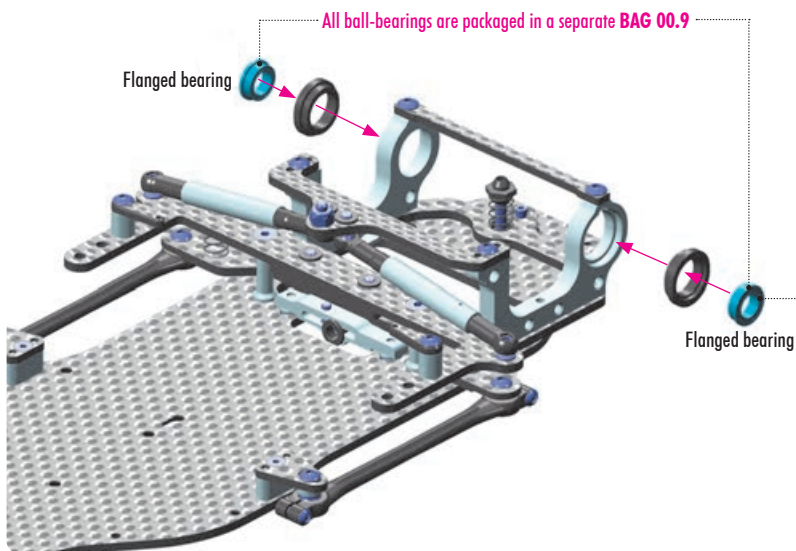

OPTION Bearing Oil (HUDY #106230)

All ball-bearings are factory pre-oiled. Regularly service, clean and lubricate all ball-bearings with HUDY Bearing Oil (#106230).



Replace the bearings as soon as they get a "gritty" feeling to prevent inefficiency and rear axle bearing blowouts.

Make sure to use only original XRAY ball-bearings which all have specific tolerances, axial and radial play and are all individually selected. Using any 3rd party ball-bearings may result into failures and break of the car.

These eccentric bushings adjust the **RIDE HEIGHT** of the rear pod. Make sure to use the **SAME** eccentric bushings on **BOTH** sides.

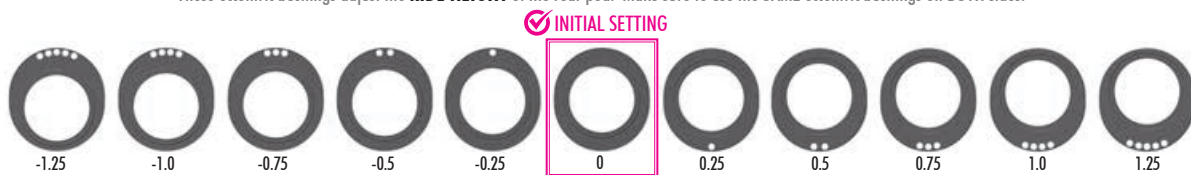

1x 964050
S 5x15x0.3



1x 972050
O 5x2



1x 980210
P 2x10

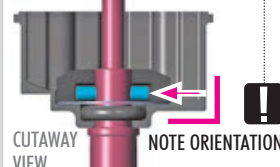
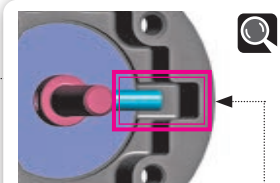
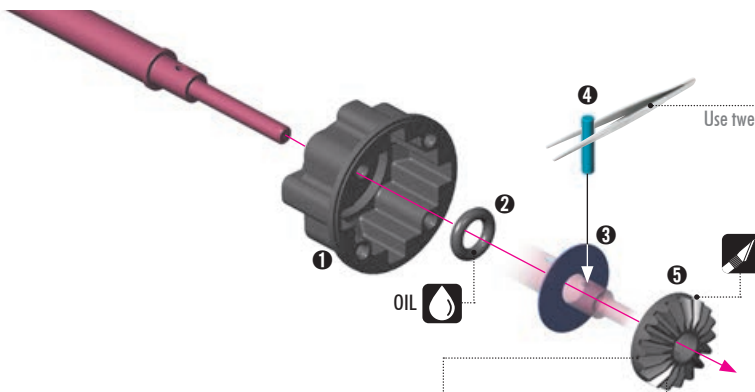

NOTE Use this satellite gear (from #304930) here.

OPTION #304932 GRAPHITE GEAR DIFF BEVEL & SATELLITE GEARS (2+4)



Use this satellite gear from kit (#374930).



4x 964031
S 3.5x10x0.2

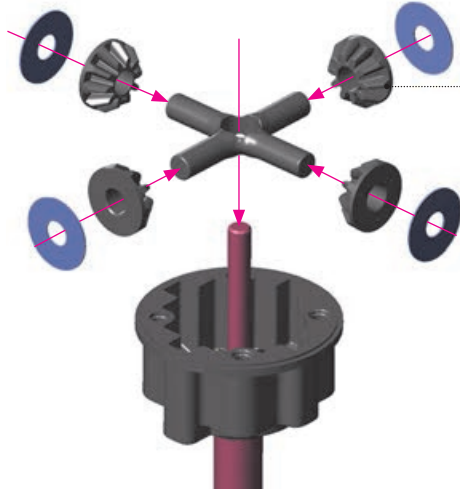

NOTE The cross pins should fit into the differential case smoothly. If not, use a hobby knife to carefully remove any excess material and recheck.



3. GEAR DIFFERENTIAL

Silicone oil
Fill just above the cross-pins.

OIL
8000 cSt

Fill differential up to the top of the diff cross-pins. DO NOT fill the diff to the top of the housing.

TIP HUDY Premium Silicone Oil - GRIP LEVEL OF TRACK

| LOW | | MEDIUM-HIGH | | SUPER-HIGH | |
|---------|---------|-------------|---------|------------|---------|
| 500 cSt | #106350 | 750 cSt | #106375 | 4000 cSt | #106440 |
| 525 cSt | #106352 | 800 cSt | #106380 | 5000 cSt | #106450 |
| 550 cSt | #106355 | 900 cSt | #106390 | 6000 cSt | #106460 |
| 575 cSt | #106357 | 1000 cSt | #106410 | 7000 cSt | #106470 |
| 600 cSt | #106360 | 2000 cSt | #106420 | 8000 cSt | #106480 |
| 625 cSt | #106362 | 3000 cSt | #106430 | 10000 cSt | #106510 |
| 650 cSt | #106365 | | | | |
| 675 cSt | #106367 | | | | |
| 700 cSt | #106370 | | | | |

NOTE: Softer oil increases steering and traction, harder oil increases stability and cornering speed of the car.

NOTE ORIENTATION

OIL

NOTE

Use this satellite gear (from #374930) here.

CUTAWAY VIEW

1x 971255 (0.25x5.0x7)

!

After disassembling the gear diff the large O-ring may have an increased size and may be more difficult to re-install. We recommend either inserting the old O-ring carefully in the diff cover, or replacing the old O-ring with a new O-ring if the old one cannot be made to fit properly.

4x 903258 (SFH M2.5x8)

2.5x8mm

2.5x8mm

!

Tighten the screws equally but DO NOT tighten them completely.

Finish tightening in this order.

3. GEAR DIFFERENTIAL



! To avoid differential oil leaking, the groove on the axle with a screw can NOT face the small hole on the axle.

✓ **CORRECT ORIENTATION**

 Hole
Groove
2.5x8mm
Groove OUT of LINE with hole – Correct

✗ **INCORRECT ORIENTATION**

 Hole
Groove
2.5x8mm
Groove INLINE with hole – Incorrect



! **NOTE ORIENTATION**

2.5x6mm

! **NOTE ORIENTATION**

CUTAWAY VIEW



! **USE THE SAME SHIMS ON BOTH SIDES.**

As option use additional shims to widen the rear track-width.

For **INITIAL SETTING** use 6.4x8.4x2mm shims.

1mm
2mm

2mm
1mm
2.5x8mm

! The axle must have a **VERY** small amount of side play. If there is no side play, the axle may bind and damage the ball-bearings.

BALL DIFFERENTIAL (NOT INCLUDED)

OPTION

- 12x 930130 B 3.1
- 1x 930138 BA 3x8
- 2x 941438 BB 1/4"x3/8"x1/8"
- 1x 960030 N M3
- 2x 963030 ST 3x8

STEP 1

OPTION

#930230 CERAMIC BALL 3.175mm (12)

OPTION

#930238 CERAMIC AXIAL THRUSTBEARING F3-8 3x8x3.5

FLANGED HUB COLLAR

! This nut affects the tightness and stiffness of the rear differential. Tighten the nut gently so the diff does not slip under power, but do not overtighten or the diff balls and/or plates may be damaged.

OPTION

- 1x 901304 SB M3x4
- 1x 981214 P 2x14

STEP 2

Hole without thread

3x4mm

- 1 Thread the set-screw deep enough into the wheel adaptor so it does not protrude.
- 2
- 3
- 4 Tighten fully.

! NOTE ORIENTATION

ASSEMBLED VIEW

DETAIL STEP 4

CUTAWAY VIEW

4. SHOCK ABSORBER

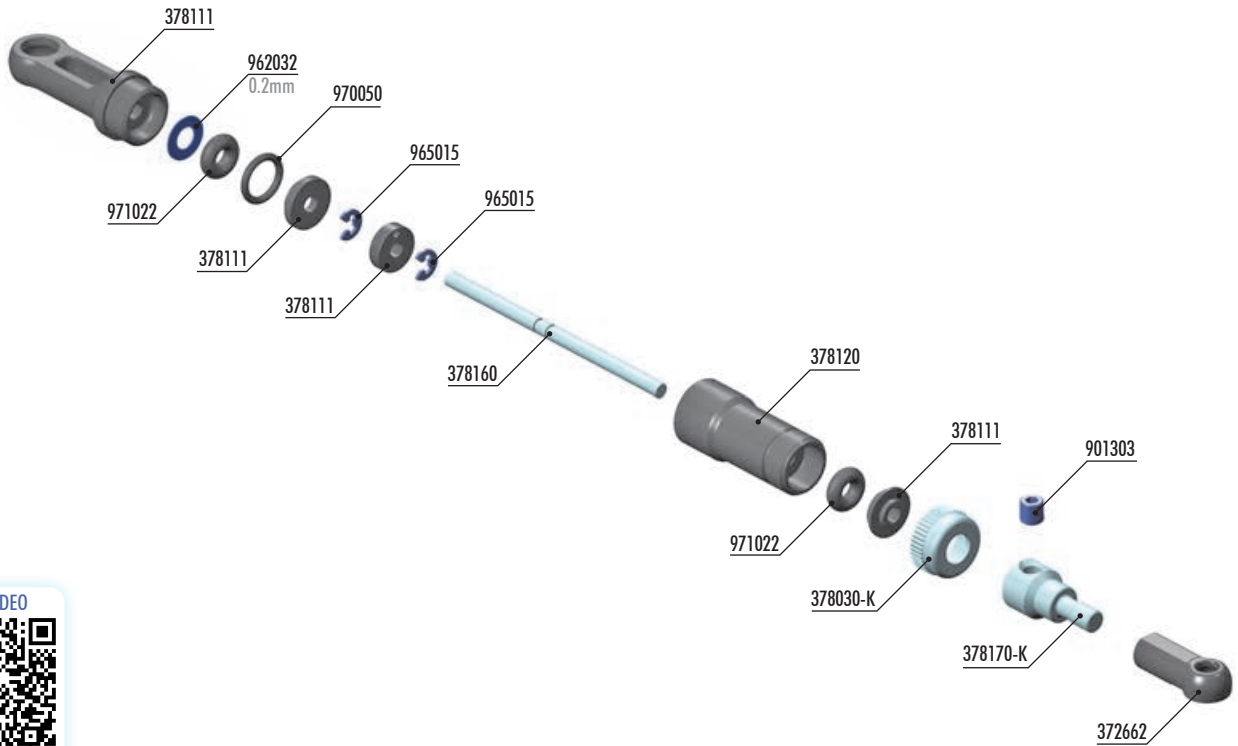

BUILD VIDEO



CENTER SHOCK



HUDY SILICONE OILS - 50ml

| | | | | | | | | |
|---------|--------|--------|---------|--------|----------|---------|---------|--------|
| #106310 | 100cSt | OPTION | #106342 | 425cSt | OPTION | #106365 | 650cSt | OPTION |
| #106315 | 150cSt | OPTION | #106345 | 450cSt | OPTION | #106367 | 675cSt | OPTION |
| #106320 | 200cSt | OPTION | #106347 | 475cSt | OPTION | #106370 | 700cSt | OPTION |
| #106325 | 250cSt | OPTION | #106350 | 500cSt | OPTION | #106375 | 750cSt | OPTION |
| #106330 | 300cSt | OPTION | #106355 | 550cSt | INCLUDED | #106380 | 800cSt | OPTION |
| #106335 | 350cSt | OPTION | #106357 | 575cSt | OPTION | #106390 | 900cSt | OPTION |
| #106337 | 375cSt | OPTION | #106360 | 600cSt | OPTION | #106410 | 1000cSt | OPTION |
| #106340 | 400cSt | OPTION | #106362 | 625cSt | OPTION | #106420 | 2000cSt | OPTION |



#104002
HUDY AIR VAC
VACUUM PUMP



BAG

04

- 372662 COMPOSITE BALL JOINT 4.2mm (4)
- 378030-K ALU SHOCK BODY CAP - LOWER - BLACK
- 378102 CENTER DAMPENER SET
- 378111 COMPOSITE CENTER DAMPENER PARTS
- 378120 ALU SHOCK BODY
- 378160 STEEL SHOCK SHAFT
- 378170-K ALU SHOCK BALL JOINT SCREW - BLACK

- 901303 HEX SCREW SB M3x3 (10)
- 962032 WASHER S 3x6x0.2 (10)
- 965015 E-CLIP 1.5 (10)
- 970050 O-RING 5x1 (10)
- 971022 SILICONE O-RING 2x2 (10)



2x 965015
C1.5

SPECIFIC ORDER

Carefully remove the shock piston from the frame, and remove all excess plastic flash.

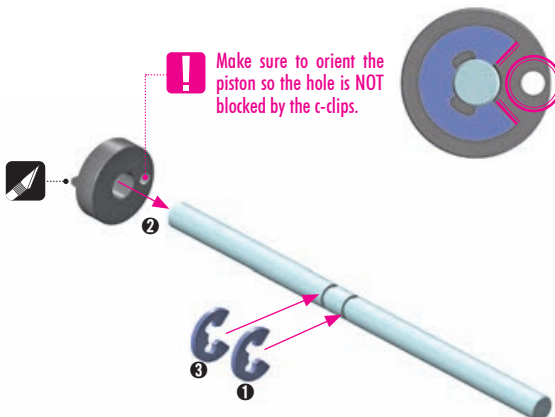

ASSEMBLED VIEW

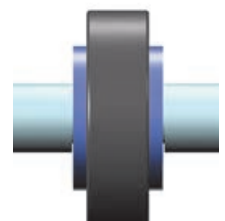

4. SHOCK ABSORBER



1x 971022
0 2x2

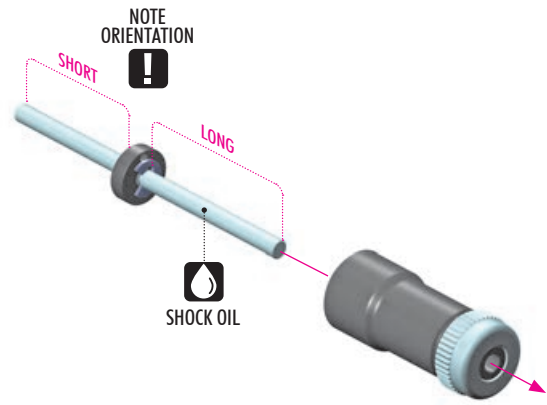
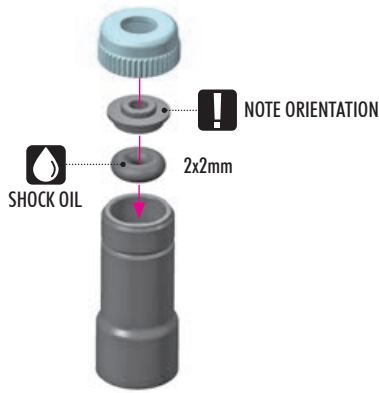

1x 970050
0 5x1



1x 971022
0 2x2



1x 962032
S 3x6x0.2

DEFAULT SHOCK SETTING FOR SHOCK ABSORBER

Follow the steps below to set the shock.

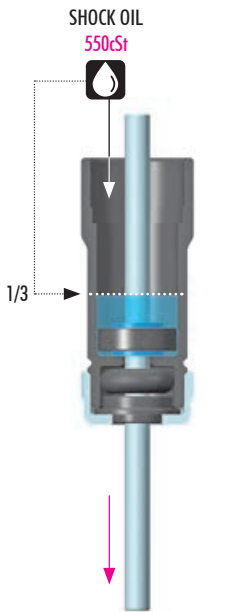

Extend the shock shaft completely. Fill the shock body with the shock oil but only 1/3.



- 1 Slowly move the shock shaft up so the shock oil will flow under the shock piston.
- 2 Extend the shock shaft.

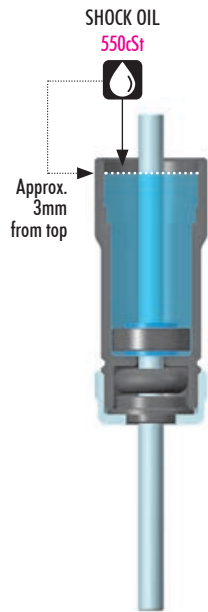

Extend the shock shaft completely to release the air trapped beneath the shock piston. Fill the shock shaft body with the shock oil but NOT fully approx. 3mm from the top of the shock body.

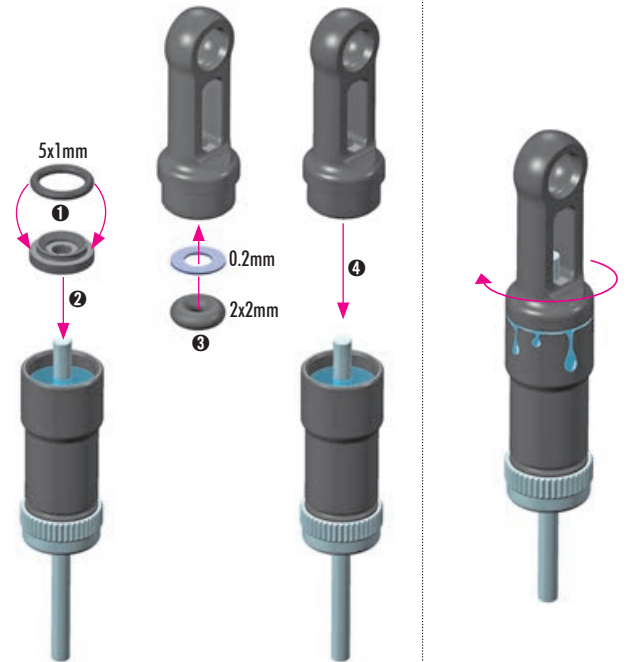

- 1 Install the 5x1mm o-ring onto shock shim.
- 2 Place the shock shim with the o-ring into the shock body.
- 3 Install the shim 0.2mm & 2x2 o-ring into the shock cap.
- 4 Install the shock cap.

Screw fully the shock cap in the filled shock body. Excess oil will spill from the shock. Tighten completely.



1x 901303
SB M3x3

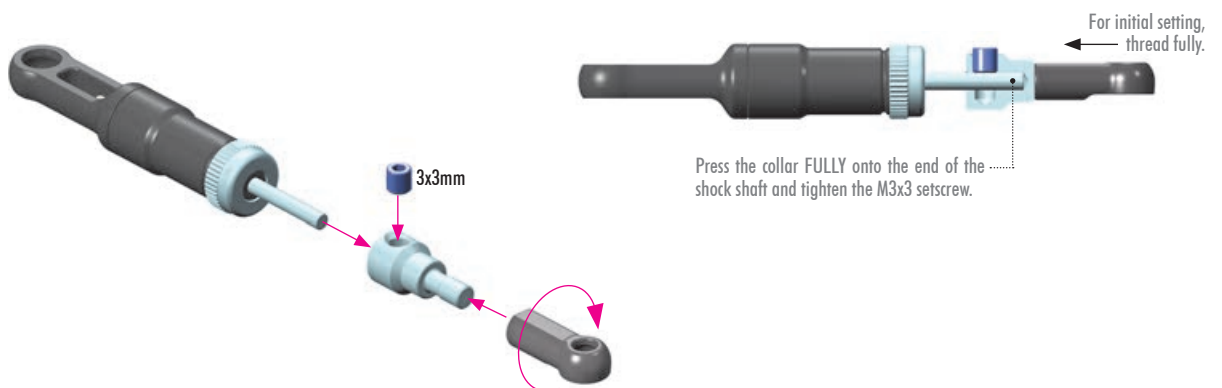

Press the collar FULLY onto the end of the shock shaft and tighten the M3x3 setscrew.

BUILD VIDEO



CENTER SHOCK

5. FINAL ASSEMBLY

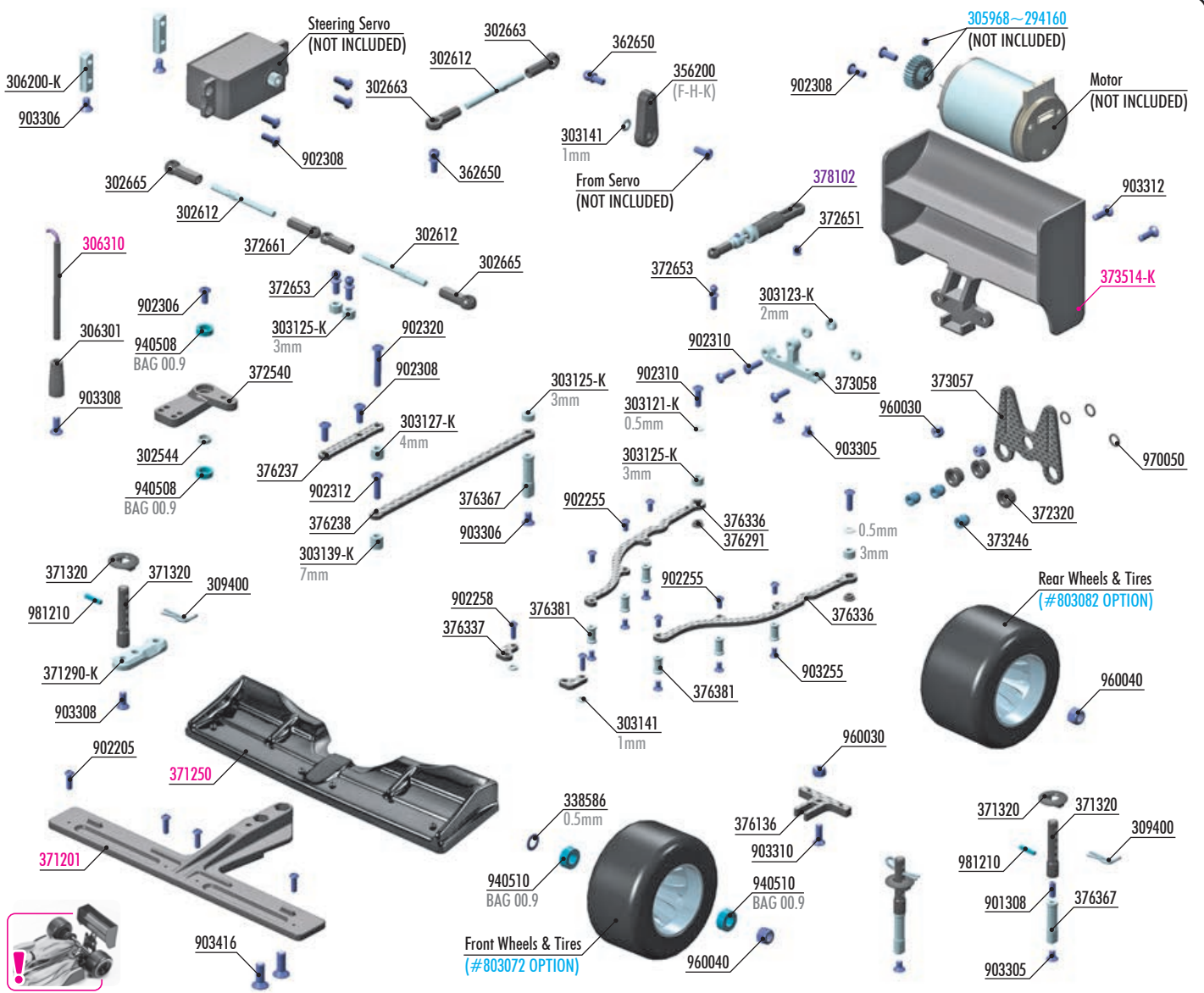

BAG

05

| | | | |
|----------|---|---------------|---|
| 302544 | ALU SHIM FOR RADIAL PLAY ADJUSTMENT OF STEERING ARM (2) | 901308 | HEX SCREW SB M3x8 (10) |
| 302612 | ALU ADJ. TURNBUCKLE M3 L/R 39mm - SWISS 7075 T6 (2) | 902205 | HEX SCREW SH M2x5 (10) |
| 302663 | COMPOSITE BALL JOINT 4.9mm - OPEN - V2 (8) | 902255 | HEX SCREW SH M2.5x5 (10) |
| 302665 | COMPOSITE BALL JOINT 4.9mm - CLOSED WITH HOLE (4) | 902258 | HEX SCREW SH M2.5x8 (10) |
| 303121-K | ALU SHIM 3x6x0.5mm - BLACK (10) | 902306 | HEX SCREW SH M3x6 (10) |
| 303123-K | ALU SHIM 3x6x2.0mm - BLACK (10) | 902308 | HEX SCREW SH M3x8 (10) |
| 303125-K | ALU SHIM 3x6x3.0mm (10) | 902310 | HEX SCREW SH M3x10 (10) |
| 303127-K | ALU SHIM 3x6x4.0mm (10) | 902312 | HEX SCREW SH M3x12 (10) |
| 303139-K | ALU SHIM 3x6x7.0mm (10) | 902320 | HEX SCREW SH M3x20 (10) |
| 303141 | ALU SHIM 3x5x1.0mm (10) | 903255 | HEX SCREW SFH M2.5x5 (10) |
| 306200-K | ALU SERVO MOUNT - BLACK (2) | 903305 | HEX SCREW SFH M3x5 (10) |
| 306301 | ANTENNA MOUNT - THIN | 903306 | HEX SCREW SFH M3x6 (10) |
| 309400 | BODY CLIP (8) | 903308 | HEX SCREW SFH M3x8 (10) |
| 356200 | BRAKE/THROTTLE ARMS & STEERING SERVO ARMS - SET | 903310 | HEX SCREW SFH M3x10 (10) |
| 362650 | BALL END 4.9mm WITH THREAD 6mm (2) | 903312 | HEX SCREW SFH M3x12 (10) |
| 371290-K | ALU BODY POST PLATE - BLACK | 903416 | HEX SCREW SFH M4x16 (10) |
| 371320 | COMPOSITE BODY POST (2) | 940508 | BALL-BEARING 5x8x2.5 RUBBER SEALED - OIL (2) |
| 372320 | X1 COMPOSITE ARM BUSHING (4) | 940510 | BALL-BEARING 5x10x4 RUBBER SEALED - OIL (2) |
| 372540 | COMPOSITE STEERING ARM | 960030 | NUT M3 (10) |
| 372651 | PIVOT BALL UNIVERSAL 4.9mm - HUDY SPRING STEEL™ (2) | 960040 | NUT M4 (10) |
| 372653 | BALL END 4.2MM WITH 8mm THREAD (2) | 970050 | O-RING 5x1 (10) |
| 372661 | COMPOSITE STEERING BALL JOINT OPEN 4.2 MM (4) | 981210 | PIN 2x10 (10) |
| 373057 | CARBON REAR WING MOUNT | 306310 | ANTENNA (2) |
| 373058 | ALU REAR WING HOLDER | 371201 | X1 COMPOSITE FRONT BUMPER |
| 373246 | ALU BALL END 6.0mm WITH HEX - SWISS 7075 T6 (2) | 371250 | X1 LEXAN FRONT SPOILER (2) |
| 376136 | CARBON BATTERY BACKSTOP - MIDDLE | 373514-K | X1 COMPOSITE REAR WING - LIGHTWEIGHT & WIDE - BLACK |
| 376237 | CARBON TOP DECK - SHORT | 378102 | CENTER DAMPENER FOR 1-PIECE CHASSIS - SET |
| 376238 | CARBON TOP DECK - LONG | 305968-294160 | ALU PINION GEAR - HARD COATED 18~64T/64P (OPTION) |
| 376291 | COMPOSITE M3 SNAP LOCK BUSHING (8) | 803072 | HUDY 1/10 FORMULA RUBBER TIRE - FRONT (2) (OPTION) |
| 376336 | CARBON SIDE BRACE FOR 1-PIECE CHASSIS (2) | 803082 | HUDY 1/10 FORMULA RUBBER TIRE - REAR (2) (OPTION) |
| 376337 | CARBON SIDE BRACE ARM (2) | | |
| 376367 | ALU MOUNT 22.5mm - BLACK | | |
| 376381 | ALU MOUNT 10.0MM WITH M2.5 THREAD - BLACK (2) | | |
| 338586 | SHIM 5x7x0.5 (10) | | |

Numbers in parentheses () refer to quantities when purchased separately.

5. FINAL ASSEMBLY

2x STEERING LINKS

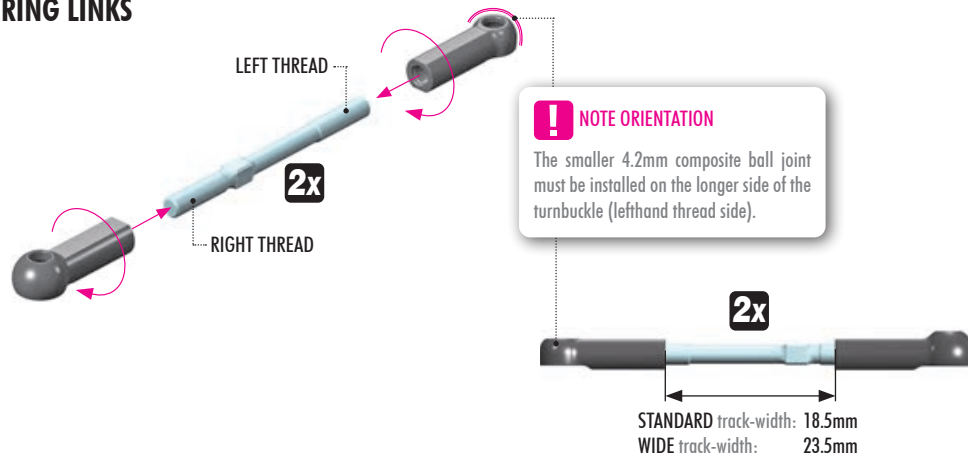

These shims adjust the bumpsteer.

When thicker shims are used here, in-corner steering increases, but the car becomes more difficult to drive.

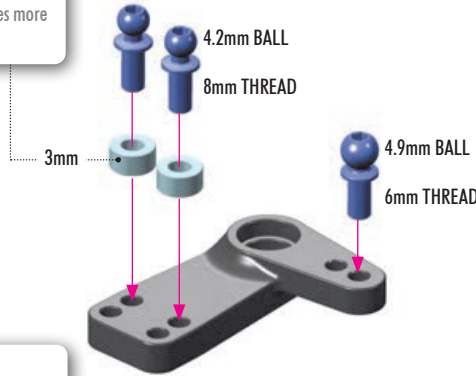

#372541-K
ALU ADJUSTABLE SERVO SAVER SET
OPTION



The steering arm has two positions for servo linkage mounting.



There are two Ackermann positions on the steering arm.

REARWARD position: More Ackermann, makes the car easier to drive, improves cornering speed. INITIAL SETTING.

FORWARD position: Less Ackermann, makes the car more responsive, improves in-corner steering.

2x L=R

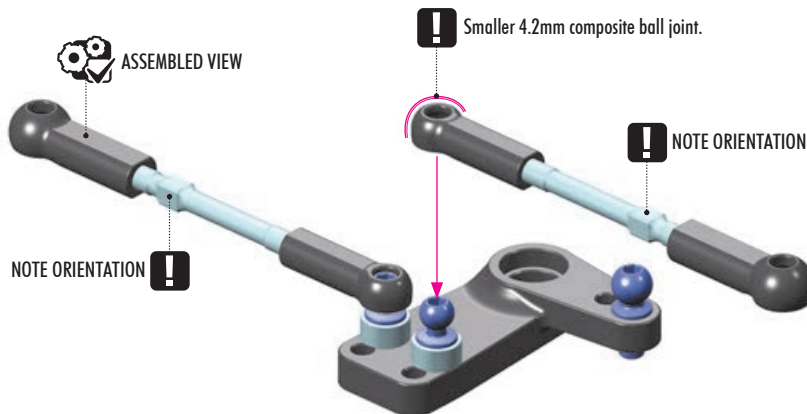

5. FINAL ASSEMBLY



306219
SHIM 3x6x1



306219
SHIM 3x6x2



306219
SHIM 3x6x3

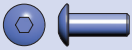

4x 902308
SH M3x8

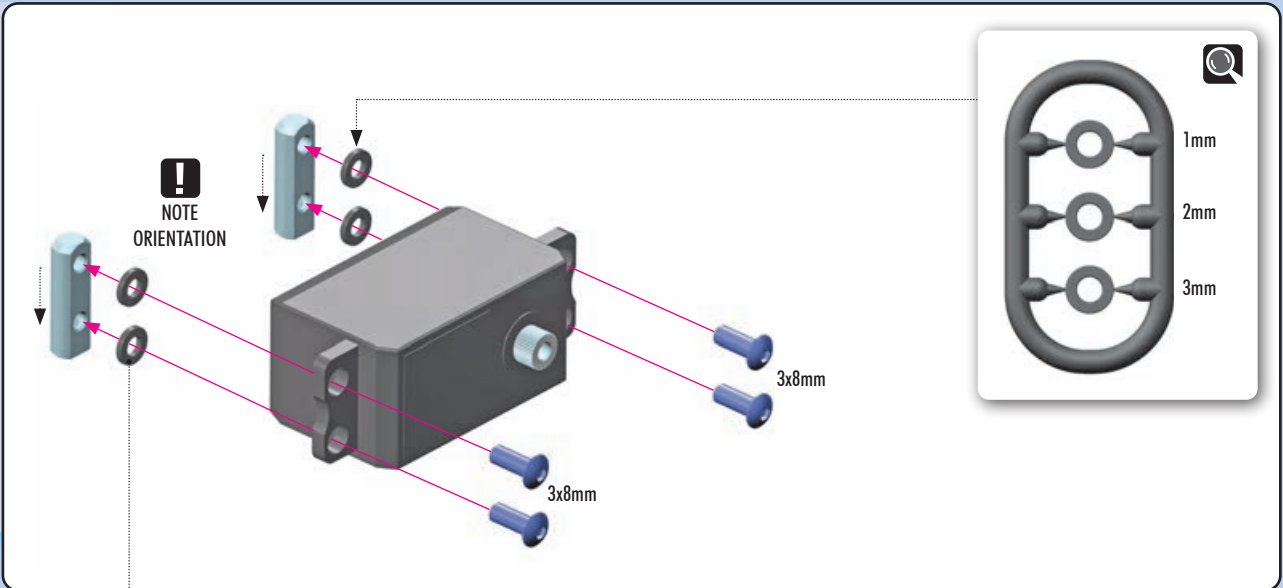

1x 303141
SHIM 3x5x1

4.9mm BALL
6mm THREAD
1mm
From Servo (NOT INCLUDED)

F (25T) = Futaba, Sawox
H (24T) = Hitec
K (23T) = KO, JR, Airtronics, Sanwa

For more in-corner steering and better steering response, aluminum servo horns may be used.

| | | |
|---------------|---------------------------------------|--|
| OPTION | HUDY ADJ. CLAMP SERVO HORNS | |
| | #293414 KO, Sanwa - 23T | |
| | #293416 Futaba, Savox - 25T | |
| OPTION | ALU SERVO HORNS - OFFSET | |
| | #293491 KO, Sanwa - 23T | |
| | #293492 Hitec - 24T | |
| | #293493 Futaba - 25T | |
| OPTION | CLAMP ALU SERVO HORNS - OFFSET | |
| | #293401 KO, Sanwa - 23T | |
| | #293402 Hitec - 24T | |
| | #293403 Futaba - 25T | |
| OPTION | HUDY ALU SERVO HORNS | |
| | #293497 KO, Sanwa - 23T | |
| | #293498 Hitec - 24T | |
| | #293499 Futaba - 25T | |
| OPTION | HUDY CLAMP ALU SERVO HORNS | |
| | #293404 KO, Sanwa - 23T | |
| | #293405 Hitec - 24T | |
| | #293406 Futaba - 25T | |
| OPTION | HUDY ALU SERVO HORNS | |
| | #293501 KO, Sanwa - 23T | |
| | #293502 Hitec - 24T | |
| | #293503 Futaba - 25T | |
| OPTION | HUDY CLAMP ALU SERVO HORNS | |
| | #293407 KO, Sanwa - 23T | |
| | #293408 Hitec - 24T | |
| | #293409 Futaba - 25T | |

SERVO SHIM **SERVO HORN SHIM**

As the servos sizes differ, use shims to move the servo out in case the servo link is too angled. Use included shims to avoid touching of the servo with side braces.

IMPORTANT! When an aluminum horn is used, the steering servo saver is NOT used. This increases the risk of breaking the servo in serious crashes.

5. FINAL ASSEMBLY

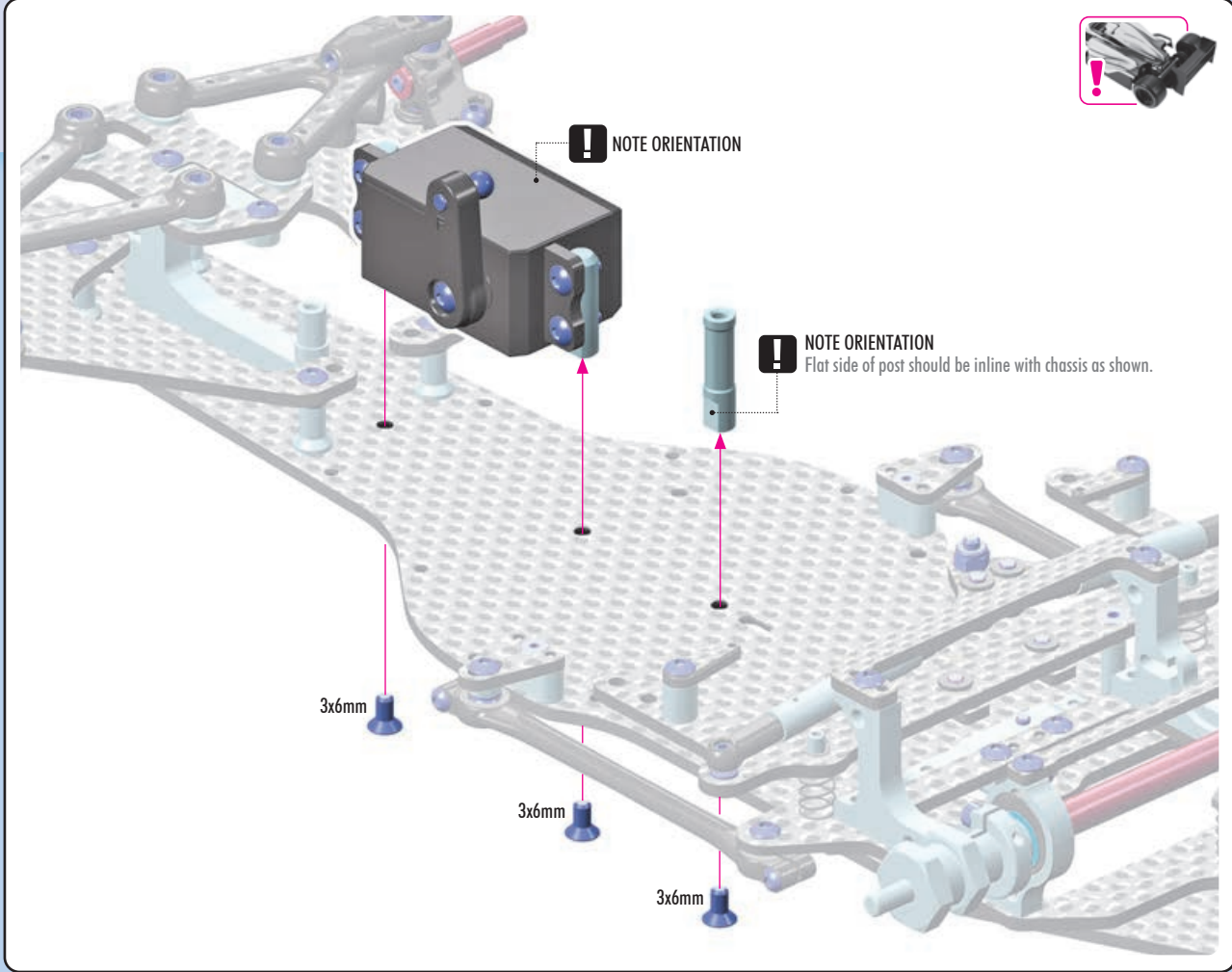

3x 903306
SFH M3x6

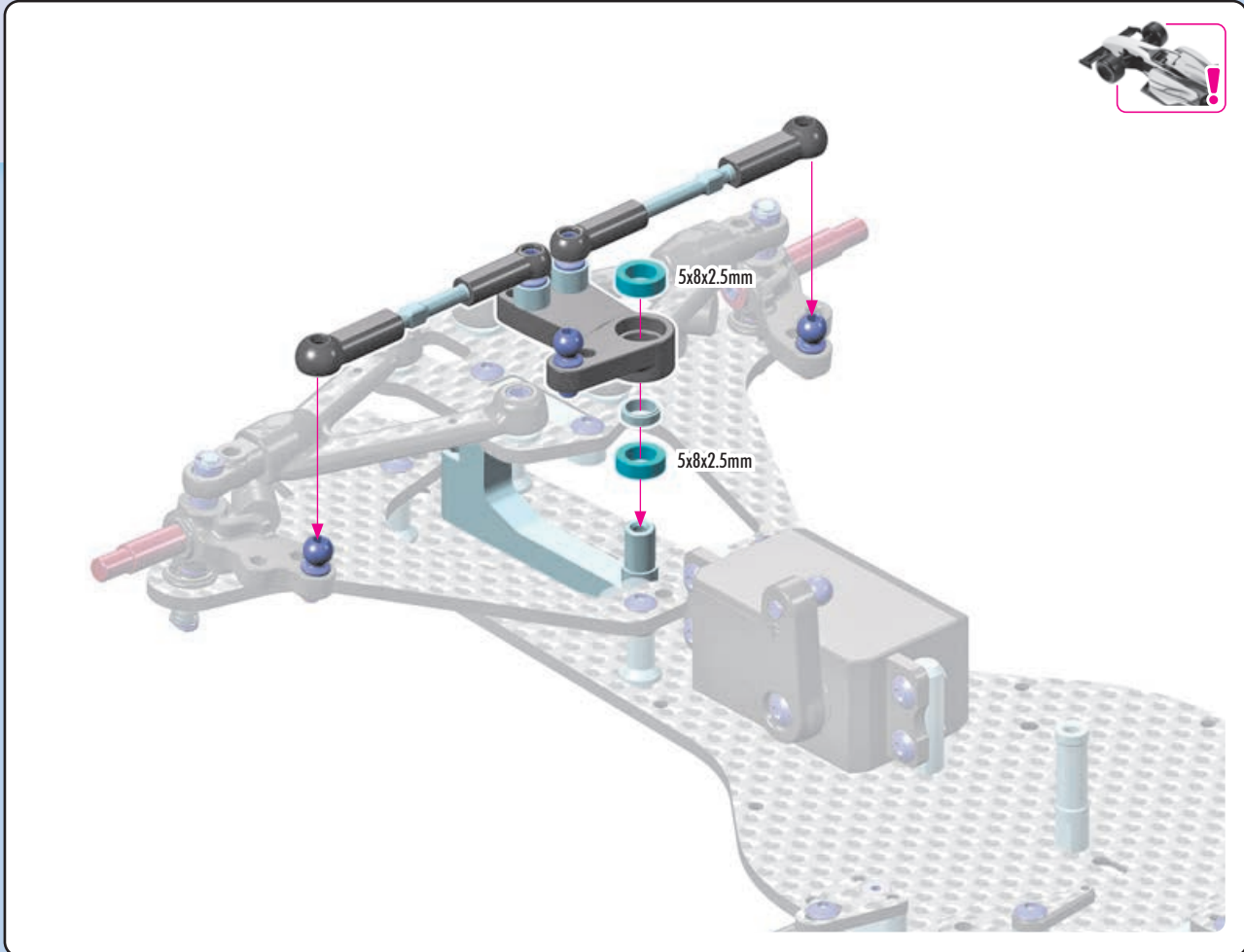

2x 940508
BB 5x8x2.5

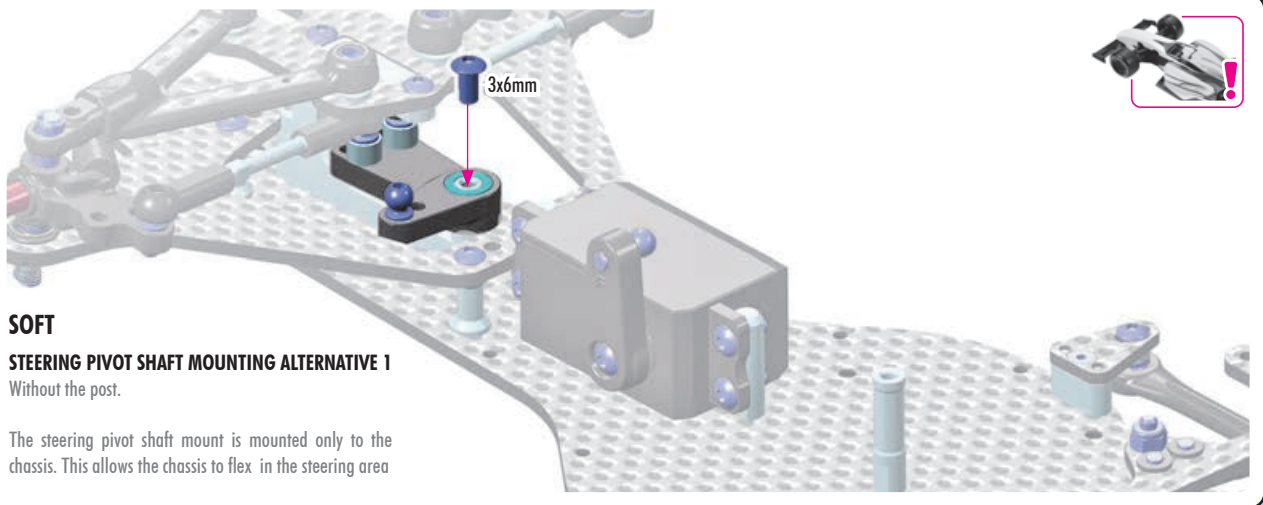

5. FINAL ASSEMBLY



SOFT
STEERING PIVOT SHAFT MOUNTING ALTERNATIVE 1
 Without the post.

The steering pivot shaft mount is mounted only to the chassis. This allows the chassis to flex in the steering area

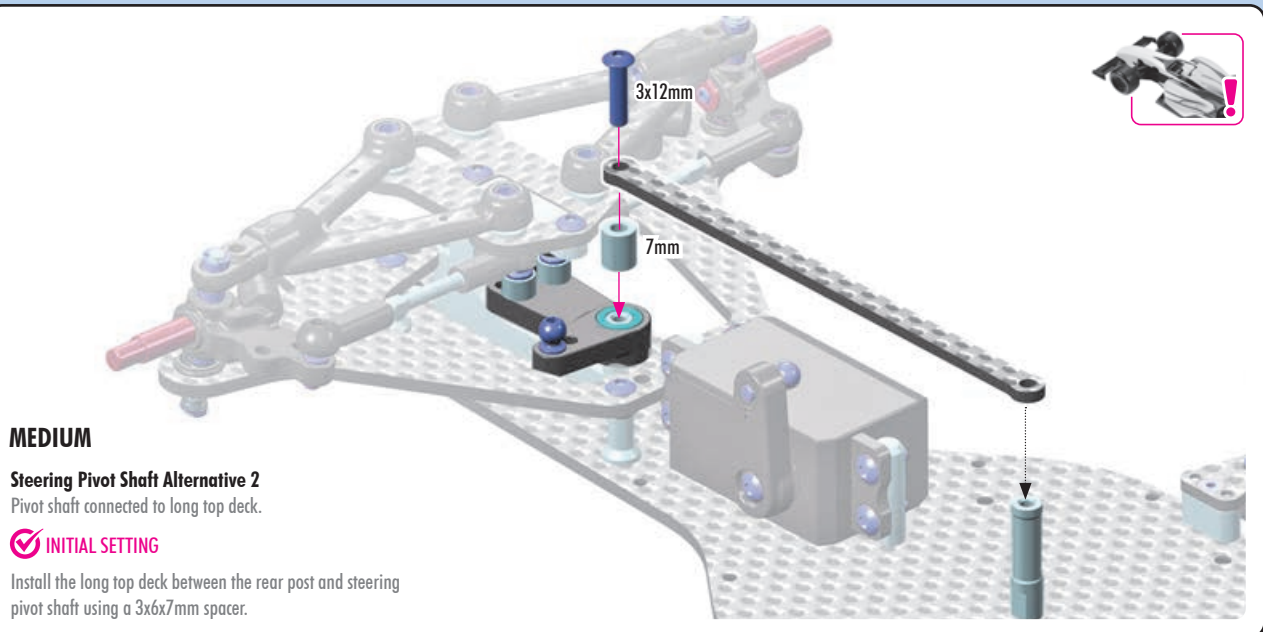
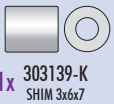

MEDIUM
Steering Pivot Shaft Alternative 2
 Pivot shaft connected to long top deck.

INITIAL SETTING

Install the long top deck between the rear post and steering pivot shaft using a 3x6x7mm spacer.

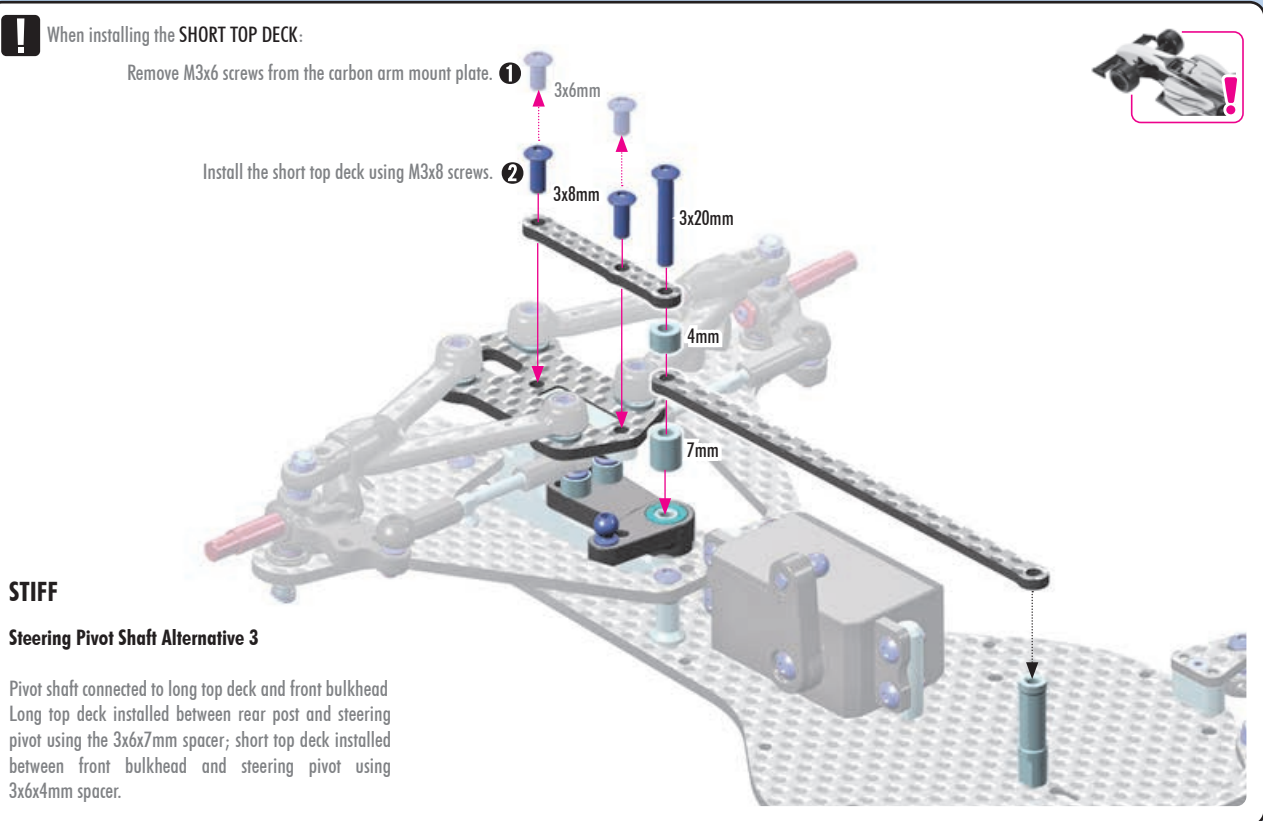
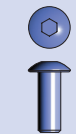
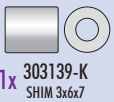

! When installing the **SHORT TOP DECK**:

Remove M3x6 screws from the carbon arm mount plate. ①

Install the short top deck using M3x8 screws. ②

STIFF
Steering Pivot Shaft Alternative 3

Pivot shaft connected to long top deck and front bulkhead
 Long top deck installed between rear post and steering pivot using the 3x6x7mm spacer; short top deck installed between front bulkhead and steering pivot using 3x6x4mm spacer.

5. FINAL ASSEMBLY



1x 303125-K
SHIM 3x6x3

1 2 3 SPECIFIC ORDER

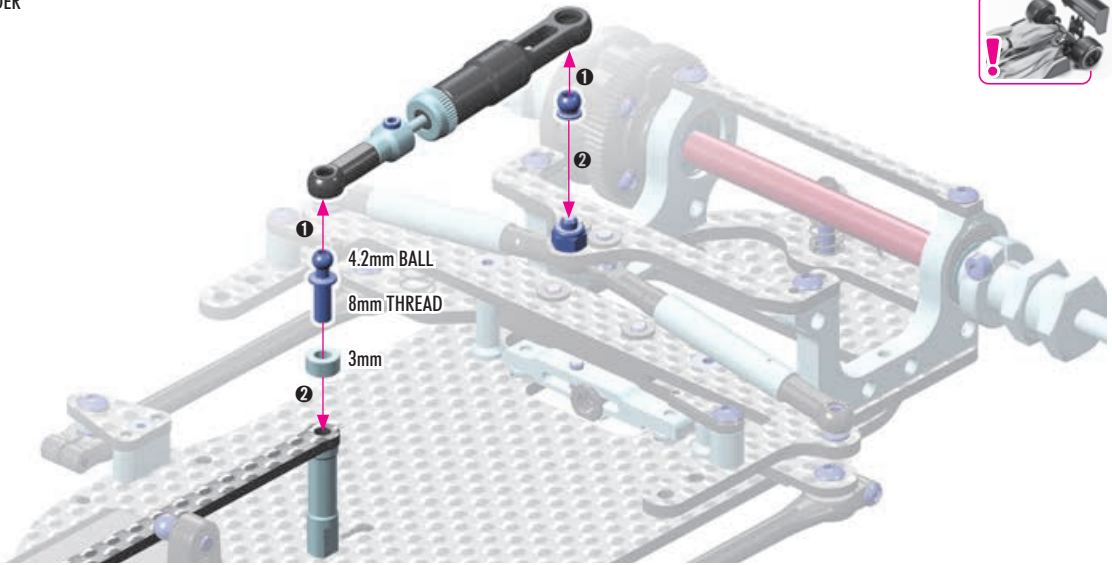

SHOCK ANGLE & POSITION

SHOCK ANGLE

More shim in front.

Makes the damping more linear. Increases stability, decreases on-power steering. Recommended for low- to medium traction track conditions.

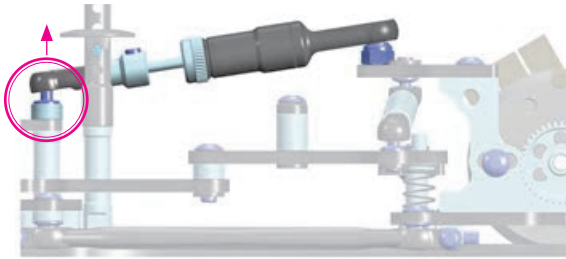

MORE SHOCK ANGLE

Less shim in front.

Makes the damping more progressive and increases on-power steering. Recommended for high-traction track conditions when you need to free up the rear.

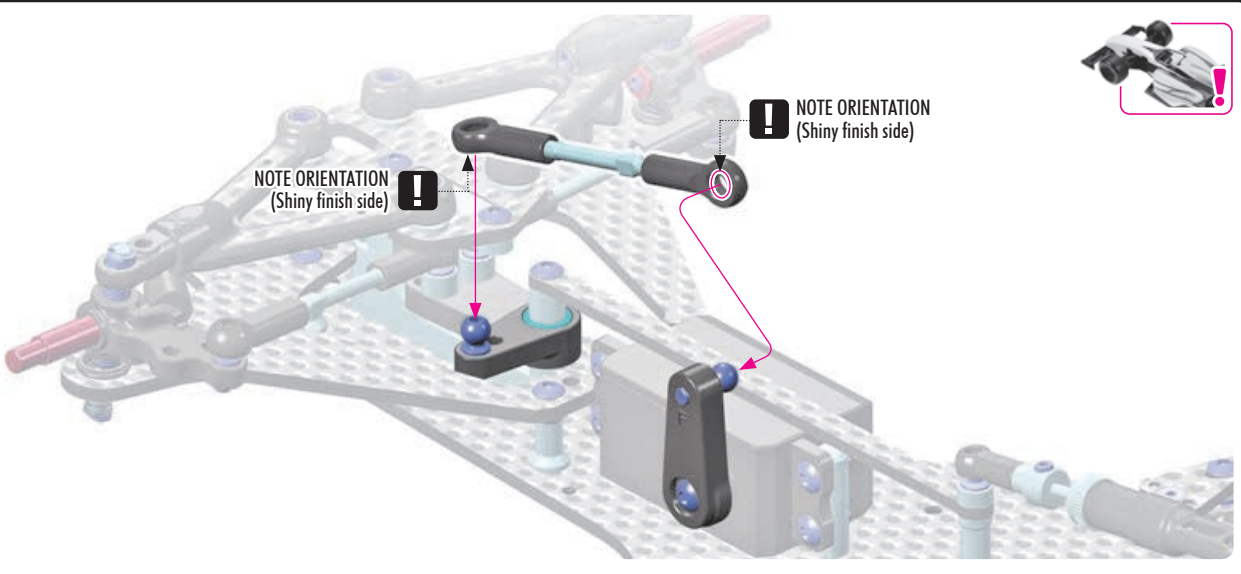
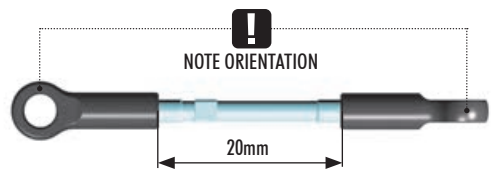
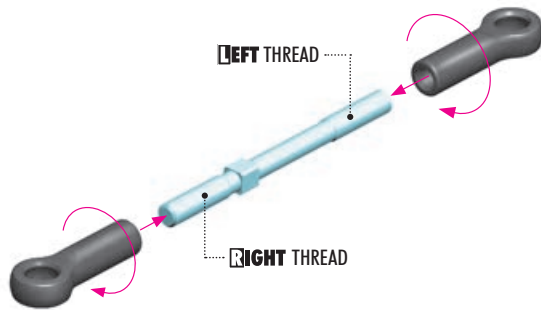
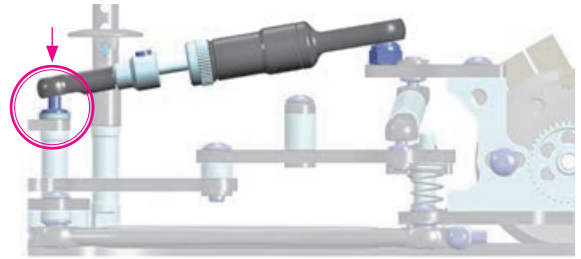

5. FINAL ASSEMBLY

- 6x 903255 SFH M2.5x5

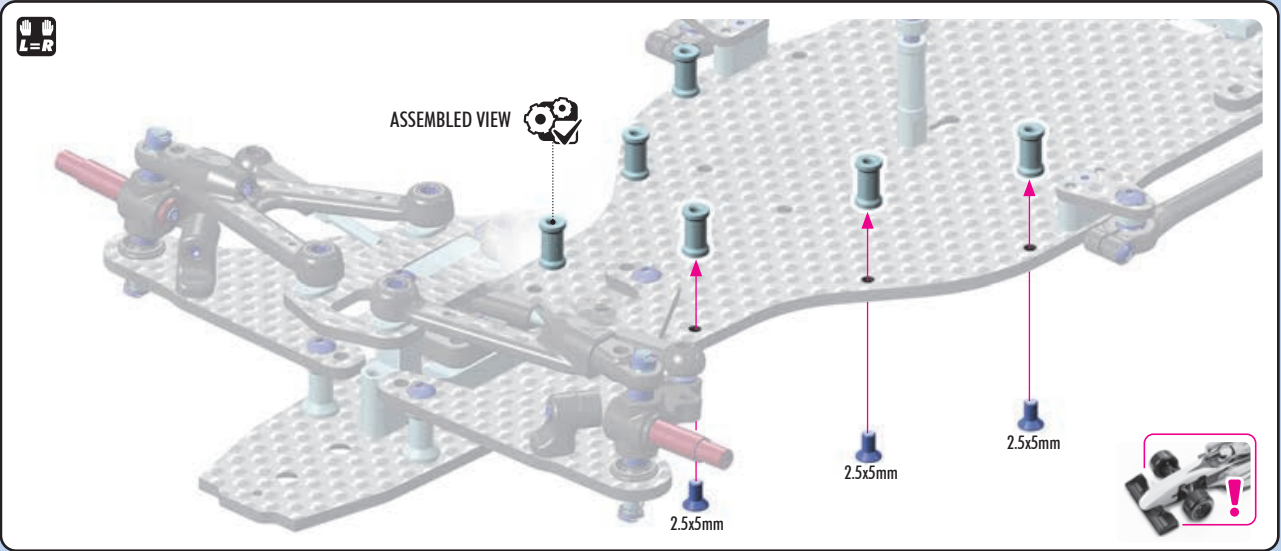

- 0x 303121-K SHIM 3x6x0.5
- 2x 303125-K SHIM 3x6x3
- 6x 902255 SH M2.5x5
- 2x 902312 SH M3x12

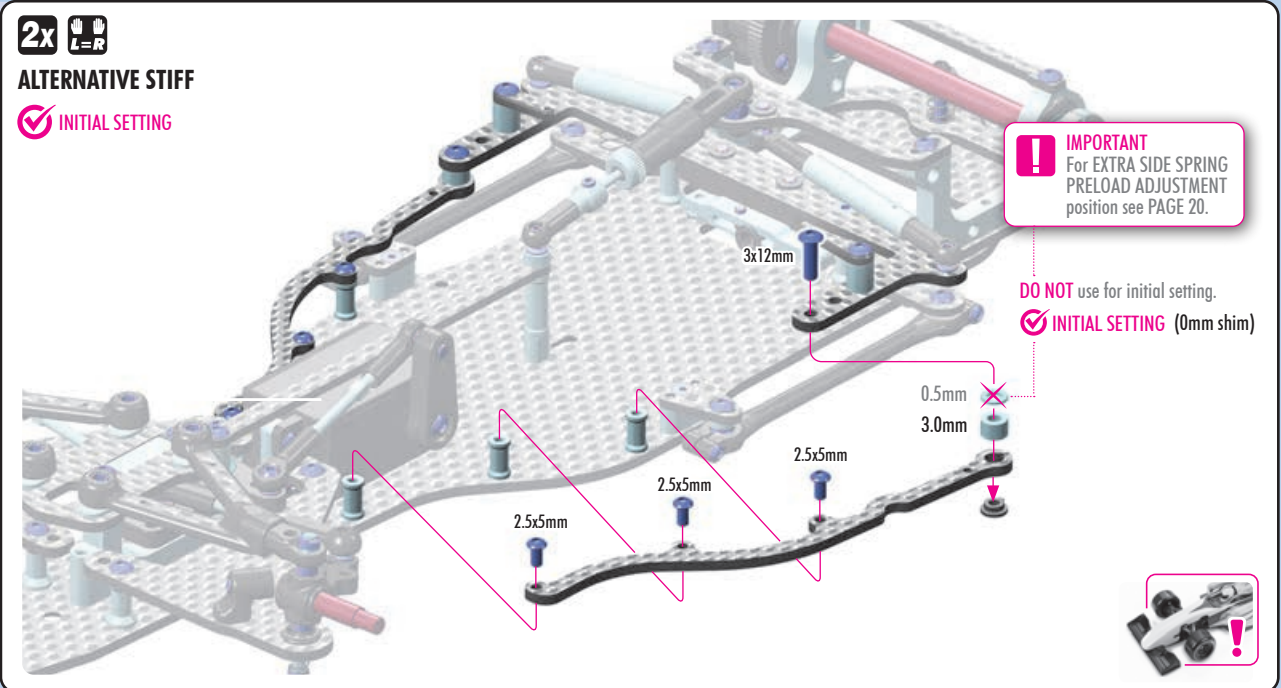

- 2x 303141 SHIM 3x5x1
- 2x 902258 SH M2.5x8
- 2x 902308 SH M3x8

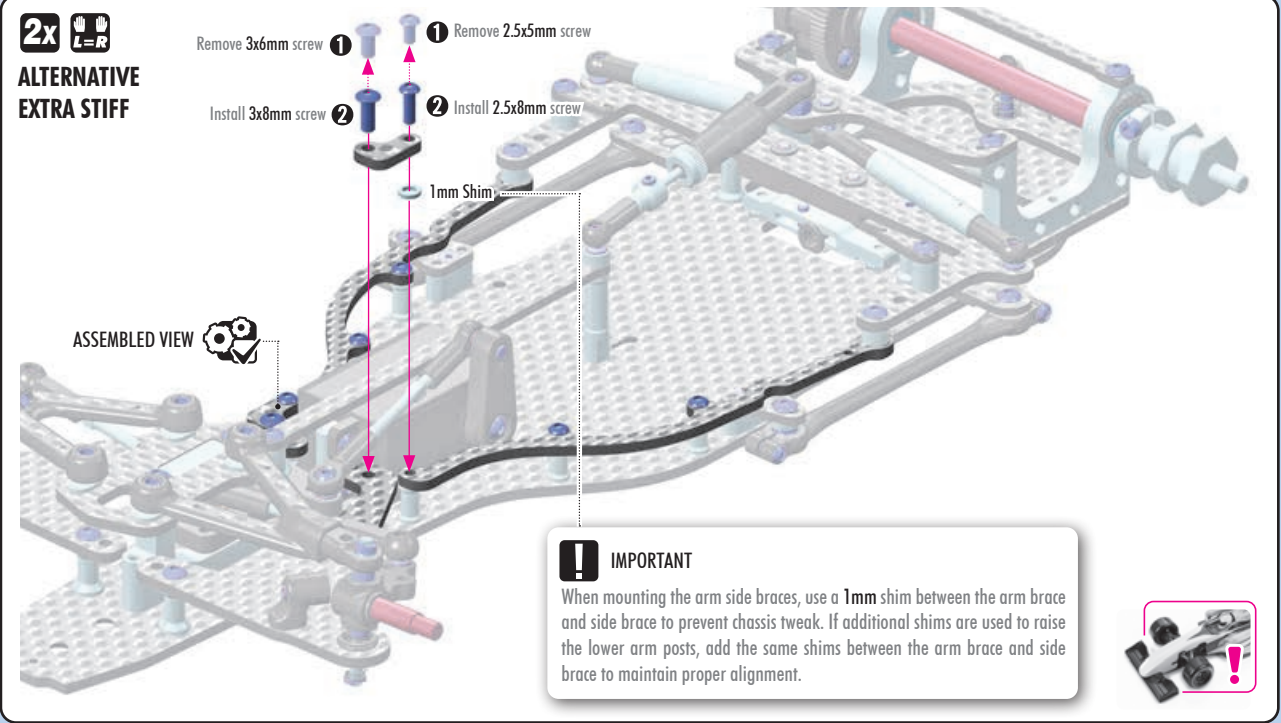

5. FINAL ASSEMBLY



CHASSIS FLEX ADJUSTMENT

SOFT (NO BRACES)

Generates more mechanical grip. Recommended for low- to medium-traction carpet as well as asphalt.



MEDIUM

Braces installed, attached at middle & rear only. This setting is a good compromise between mechanical grip and steering response. Ideal for most conditions.

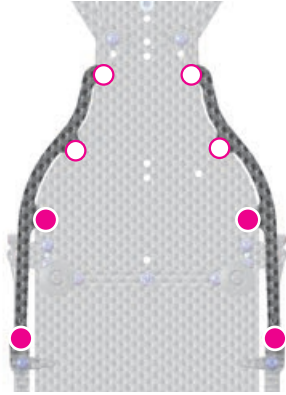

STIFF INITIAL SETTING

Side braces installed, attached using front, front-middle, middle, and rear screws. This setting provides additional stiffness and more stability. Recommended for high traction carpet (ex: US black carpet). Reduces chassis roll but also reduces overall grip. Recommended for foam tire racing.

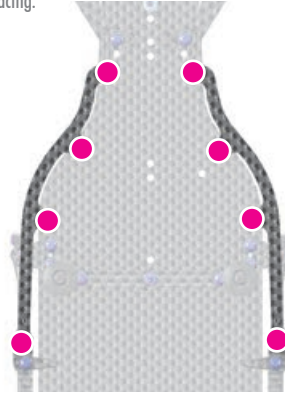

EXTRA STIFF

Side braces installed, attached using front, front-middle, middle, and rear screws. Front arm braces are installed between lower arms and side braces. This setting provides maximum chassis stiffness and stability. Recommended for foam tire racing.

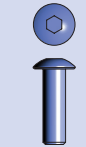
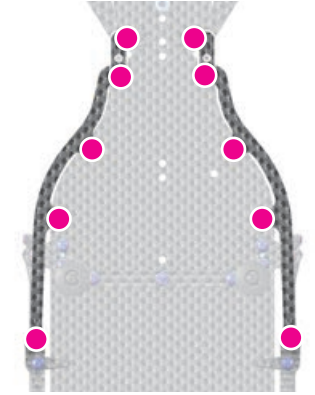

3x 902310
SH M3x10



2x 903305
SFH M3x5

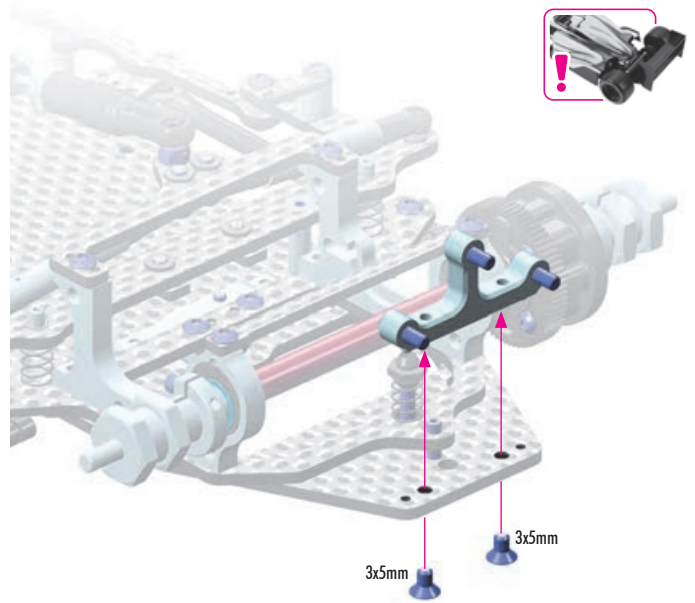
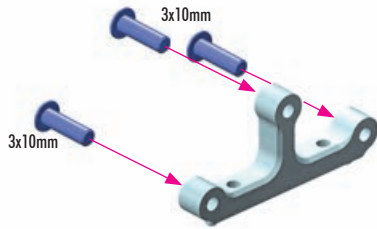

3x 970050
O 5x1

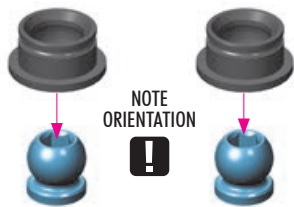

NOTE
ORIENTATION



TIP



Install with HUDY Multi Tool.

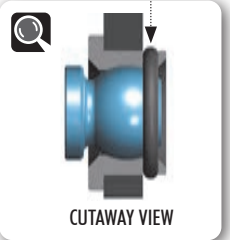
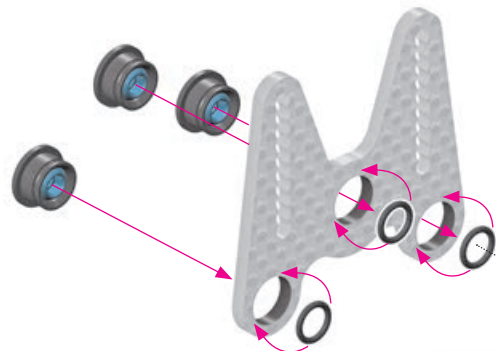

CUTAWAY VIEW

5. FINAL ASSEMBLY

3x 303123-K
SHIM 3x6x2

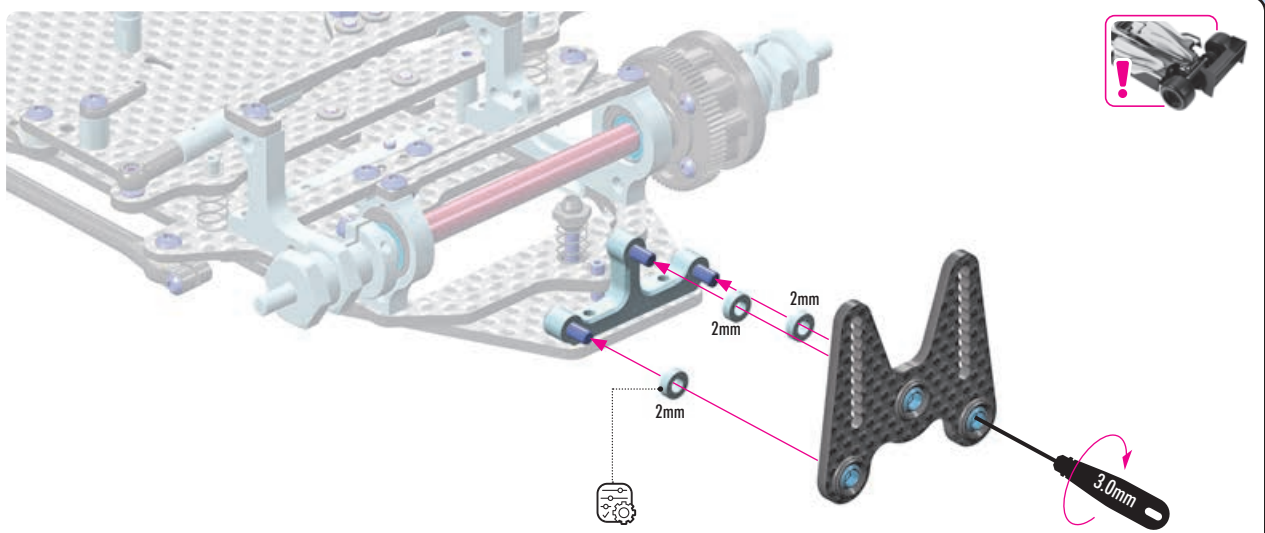

WING ANGLE ADJUSTMENT

STANDARD DOWNFORCE

✓ INITIAL SETTING

Setting for best aerodynamic efficiency. This is the standard option for most tracks and most wings. It is a good compromise between downforce and drag as well as high speed stability and high speed rotation.

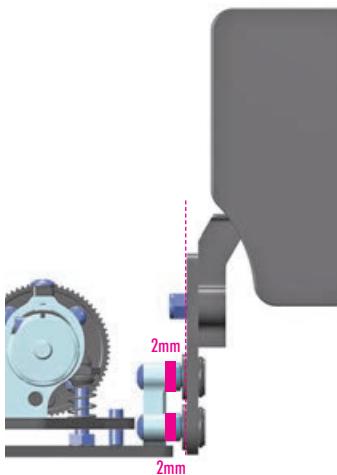

ANGLED FORWARD

This gives more rear downforce for many rear wings at the cost of increased drag. Use this for smaller tracks where drag is NOT a lot of concern, or when you struggle with rear stability in high speed sections of the track.

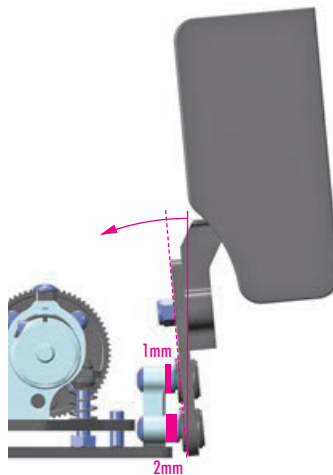

ANGLED BACKWARDS

This gives reduced drag at the cost of reduced downforce. Use this for large tracks, when you are NOT concerned of rear instability at high speed. Make sure NOT to use too large front wings in this combination.

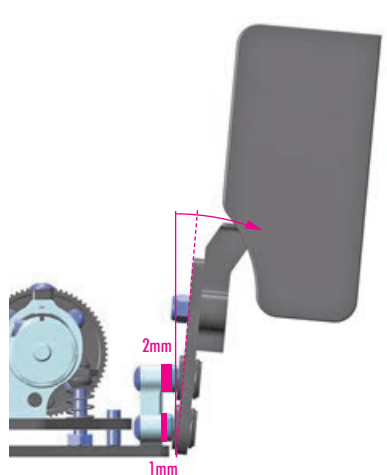

2x 903312
SFH M3x12

2x 960030
N M3

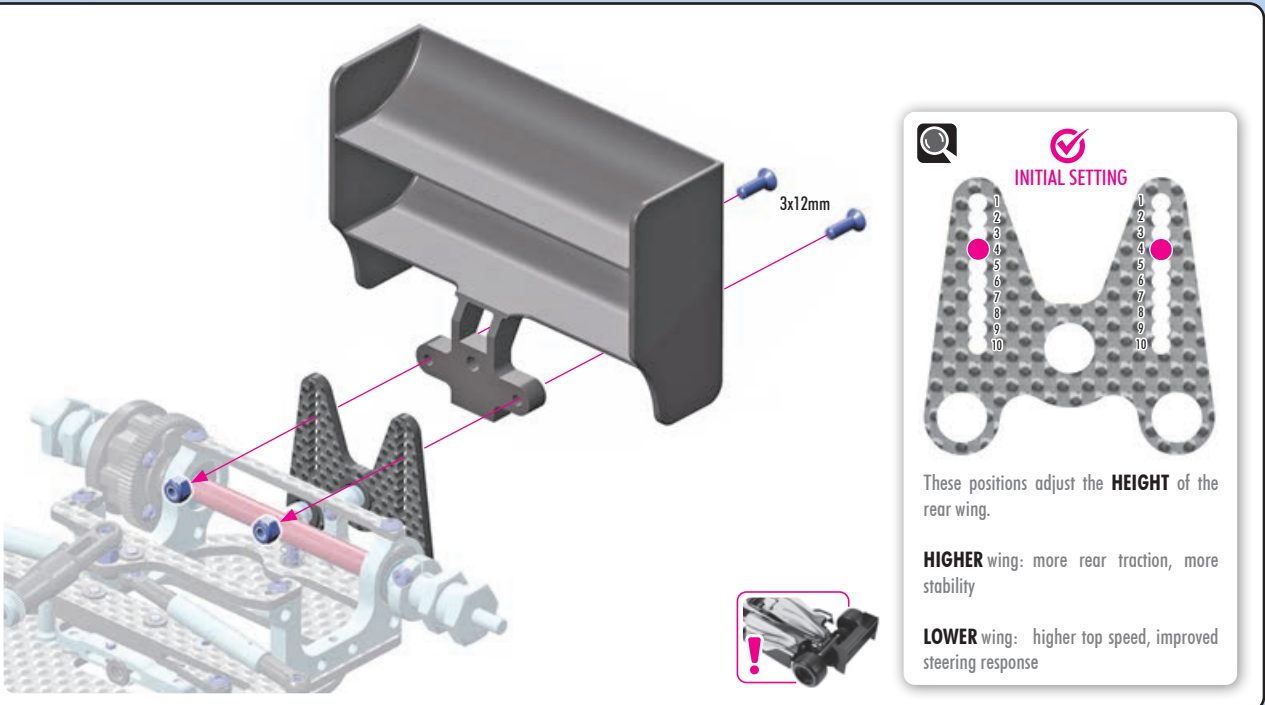

These positions adjust the **HEIGHT** of the rear wing.

HIGHER wing: more rear traction, more stability

LOWER wing: higher top speed, improved steering response

5. FINAL ASSEMBLY



8x 906206
SFP 2.2x6



#373513-K
X1 COMPOSITE ADJUSTABLE REAR WING - BLACK - ETS APPROVED

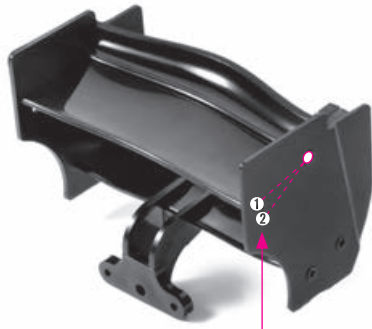

WING POSITION

1 LOW DOWNFORCE:

Low downforce setting is recommended on tracks where top speed is more important over rear stability on-power/in high speed corners.

2 HIGH DOWNFORCE:

High downforce setting recommended for most tracks.



#373514
X1 COMPOSITE REAR WING - LIGHTWEIGHT & WIDE - WHITE



2x 903305
SFH M3x5

2x L=R

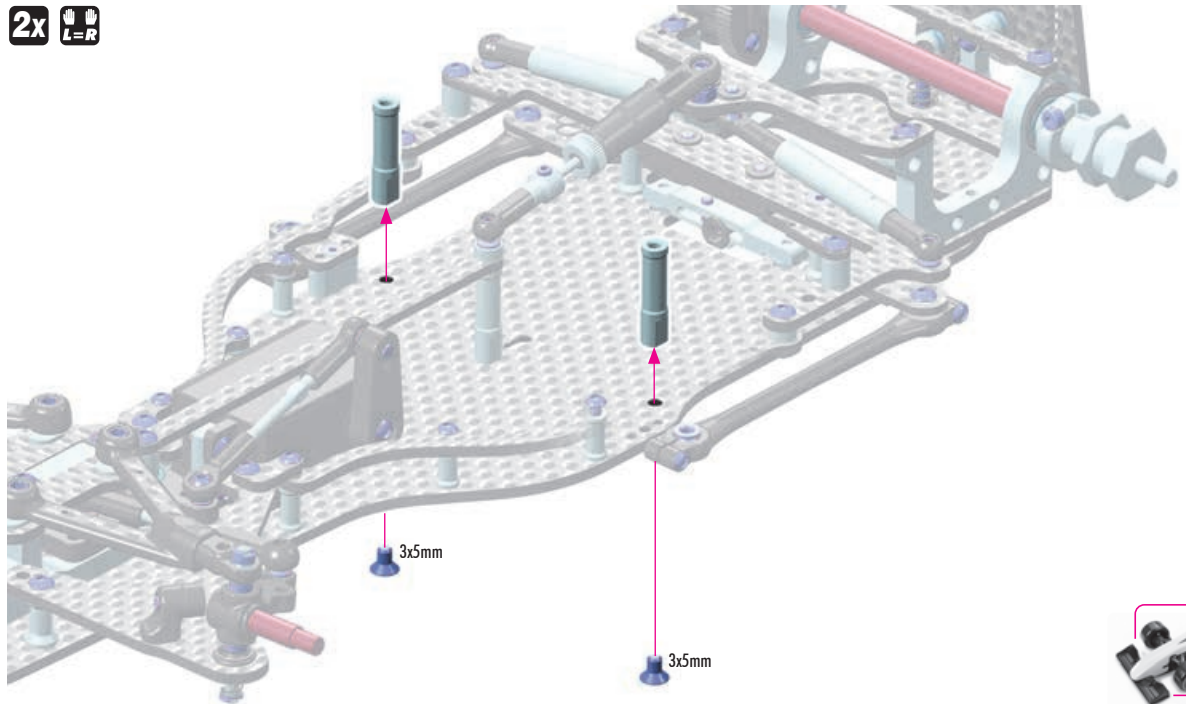

2x 901308
SB M3x8

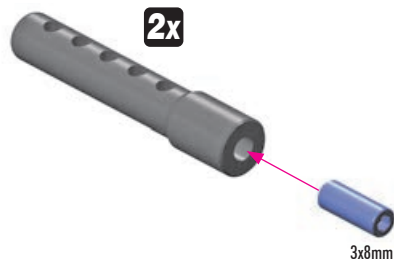

2x

3x8mm



4mm

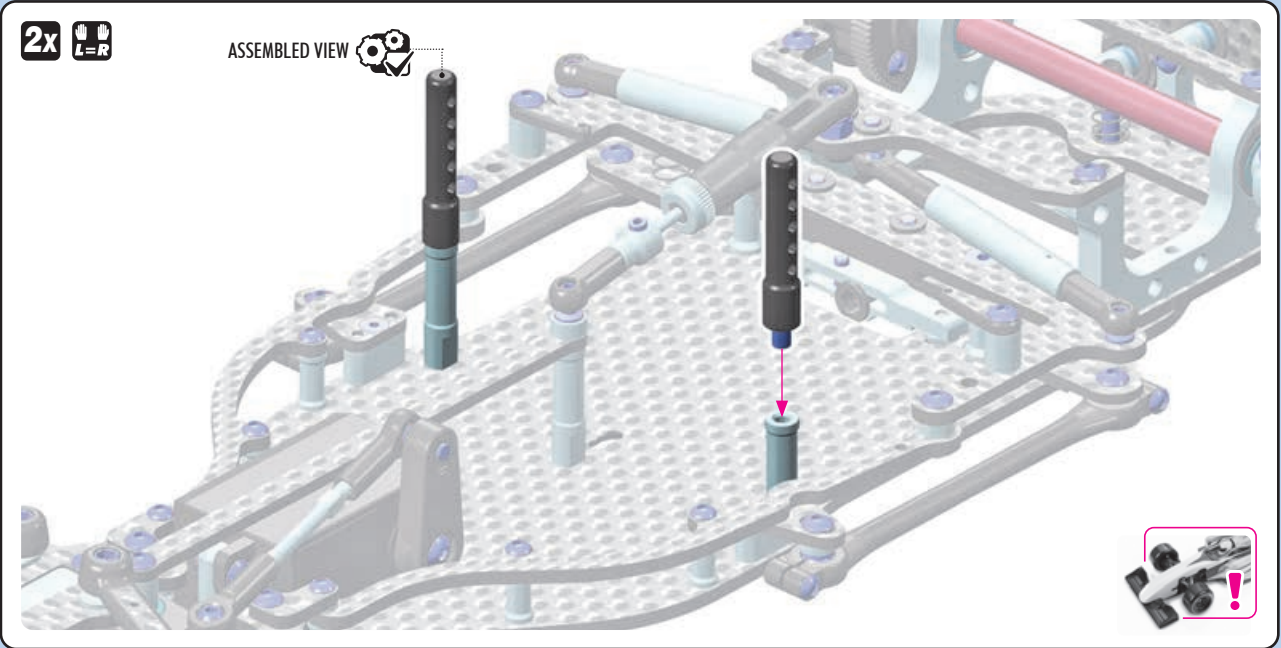

2x L=R

ASSEMBLED VIEW

2x 981210
P 2x10

2x L=R

REAR BODY POSTS MOUNTING ALTERNATIVES ALTERNATIVE 1

INITIAL SETTING

In case you are using higher batteries, mount the body posts on the aluminum posts alternative.

#301351-0
ALU ADJUSTABLE BODY
POST STOP (2)
OPTION



#301351-K
ALU ADJUSTABLE BODY
POST STOP (2)
OPTION

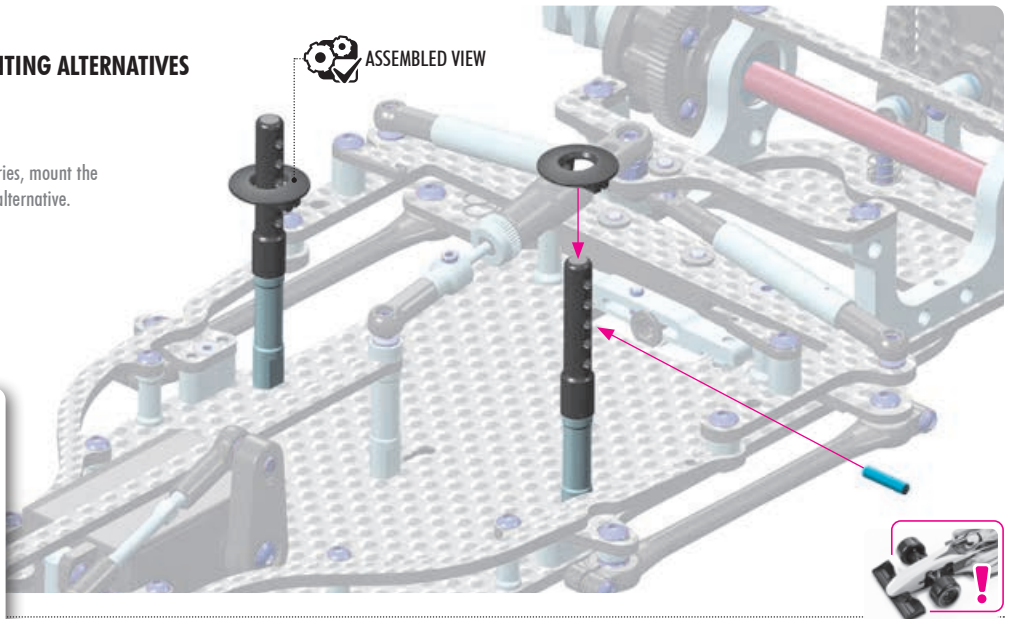

ASSEMBLED VIEW

902308
SH M3x8

2x L=R

ALTERNATIVE 2

In case you are using small height batteries, there is an option to mount the body posts on the carbon rear brace which would allow to clear the space in front of the battery and there will be even more space for electronics.

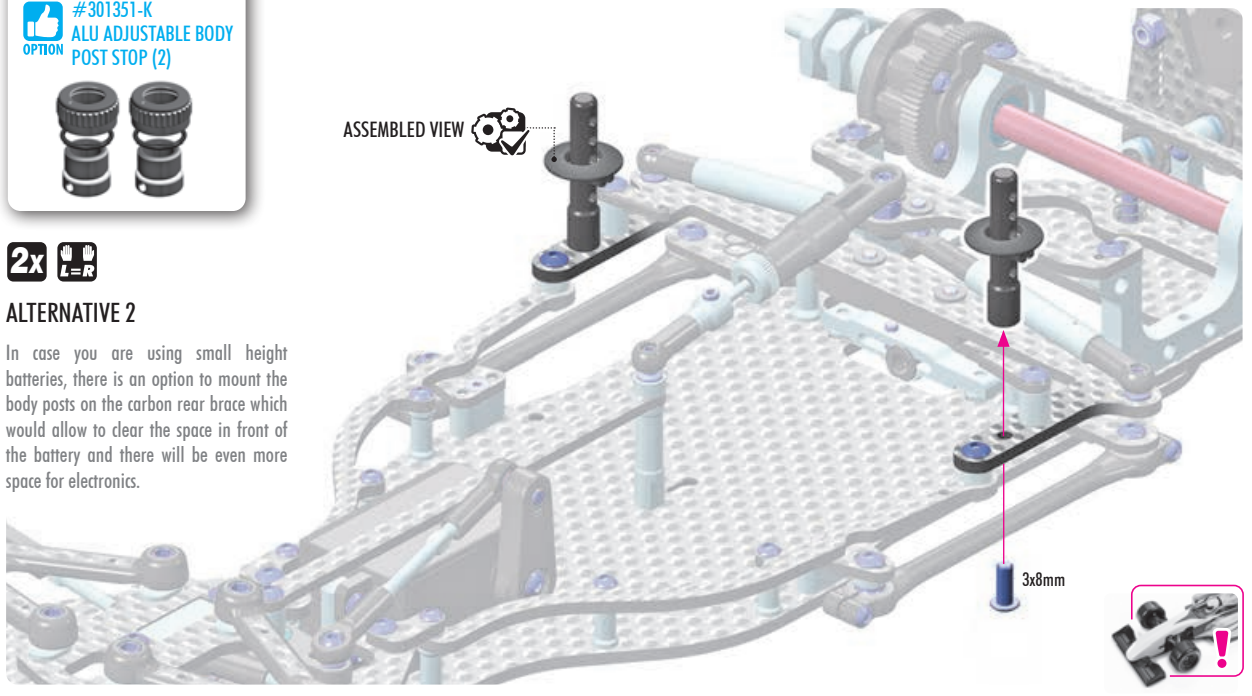

ASSEMBLED VIEW

3x8mm

5. FINAL ASSEMBLY



OPTION

ALU PINION GEARS HARDCOATED - 64P

| | | | | | |
|---------|-----|--------|---------|-----|--------|
| #305968 | 18T | OPTION | #294137 | 37T | OPTION |
| #305969 | 19T | OPTION | #294138 | 38T | OPTION |
| #305970 | 20T | OPTION | #294139 | 39T | OPTION |
| #305971 | 21T | OPTION | #294140 | 40T | OPTION |
| #305972 | 22T | OPTION | #294141 | 41T | OPTION |
| #305973 | 23T | OPTION | #294142 | 42T | OPTION |
| #305974 | 24T | OPTION | #294143 | 43T | OPTION |
| #305975 | 25T | OPTION | #294144 | 44T | OPTION |
| #294126 | 26T | OPTION | #294145 | 45T | OPTION |
| #294127 | 27T | OPTION | #294146 | 46T | OPTION |
| #294128 | 28T | OPTION | #294147 | 47T | OPTION |
| #294129 | 29T | OPTION | #294148 | 48T | OPTION |
| #294130 | 30T | OPTION | #294149 | 49T | OPTION |
| #294131 | 31T | OPTION | #294150 | 50T | OPTION |
| #294132 | 32T | OPTION | #294152 | 52T | OPTION |
| #294133 | 33T | OPTION | #294154 | 54T | OPTION |
| #305984 | 34T | OPTION | #294156 | 56T | OPTION |
| #305985 | 35T | OPTION | #294158 | 58T | OPTION |
| #294136 | 36T | OPTION | #294160 | 60T | OPTION |



#901302 (SB M3x2.5)
(NOT INCLUDED)

Pinion
(NOT INCLUDED)

Motor
(NOT INCLUDED)

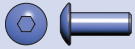

2x 902308
SH M3x8

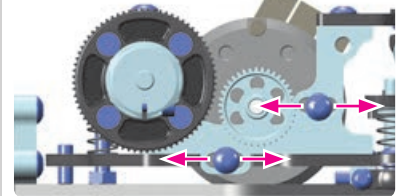
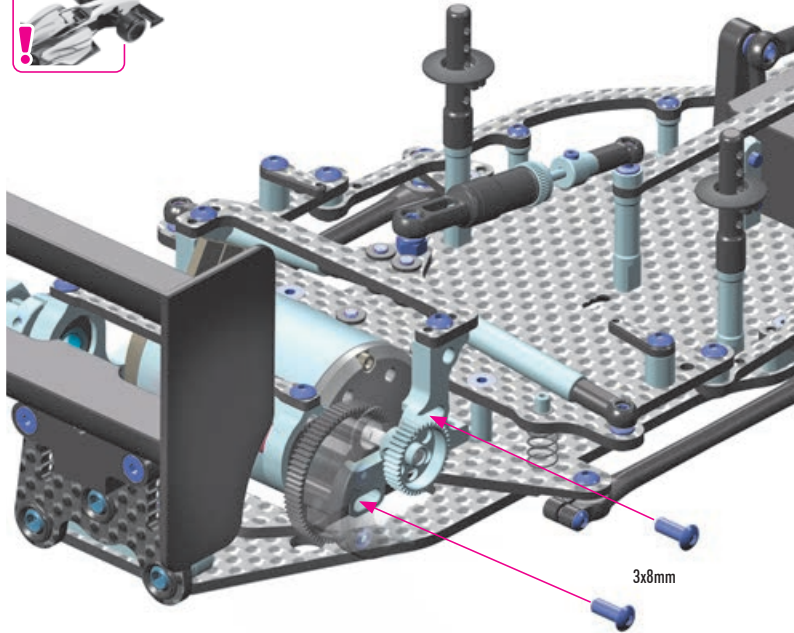

Adjust the gear mesh so there is appropriate space between the spur gear and pinion teeth. There should be a very small amount of freeplay.



1x 903308
SFH M3x8

Speed Controller
(NOT INCLUDED)

Receiver
(NOT INCLUDED)

Receiver Wire

Double-sided Tape
HUDY #107875
(NOT INCLUDED)



OPTION

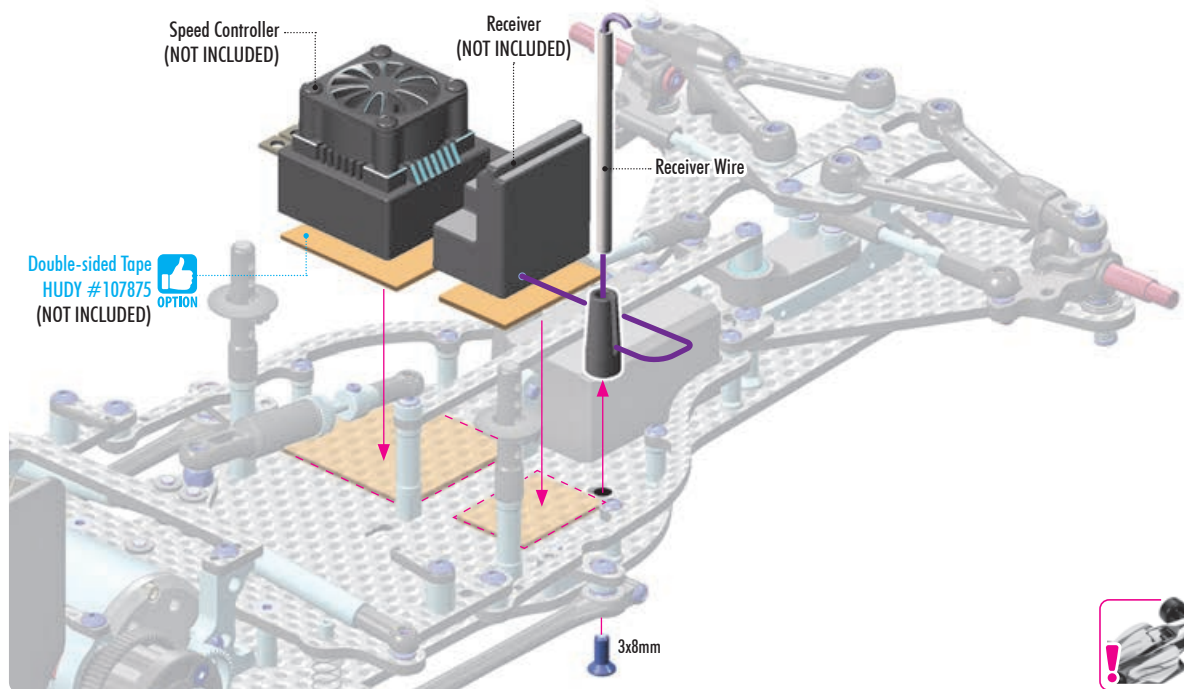

5. FINAL ASSEMBLY



Battery Pack (NOT INCLUDED)
The battery pack has to be angled when installing or removing it from the car.

! The shock has to be removed on one end when installing or removing the battery pack from the car.

NOTE ORIENTATION

! Make sure to have a small amount of play

The play must be adjusted using appropriate shims as there are different battery packs in the market with different heights.

3x10mm

BATTERY MOUNTING POSITIONS

The X1 has 3 battery mounting positions.

The **MORE REARWARD** the battery is, the car will be more aggressive and have more steering.

The **MORE FORWARD** the battery is, the car will be easier to drive but it will be less responsive.

» More aggressive
» More steering

REARWARD battery placement

INITIAL SETTING

» Easier to drive
» Less responsive

FORWARD battery placement

5. FINAL ASSEMBLY

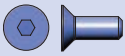

1x 903308
SFH M3x8



1x 981210
P 2x10



2x 903416
SFH M4x16

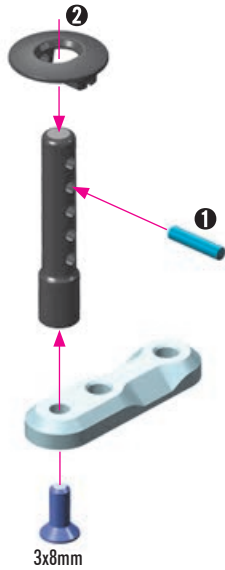

3x8mm

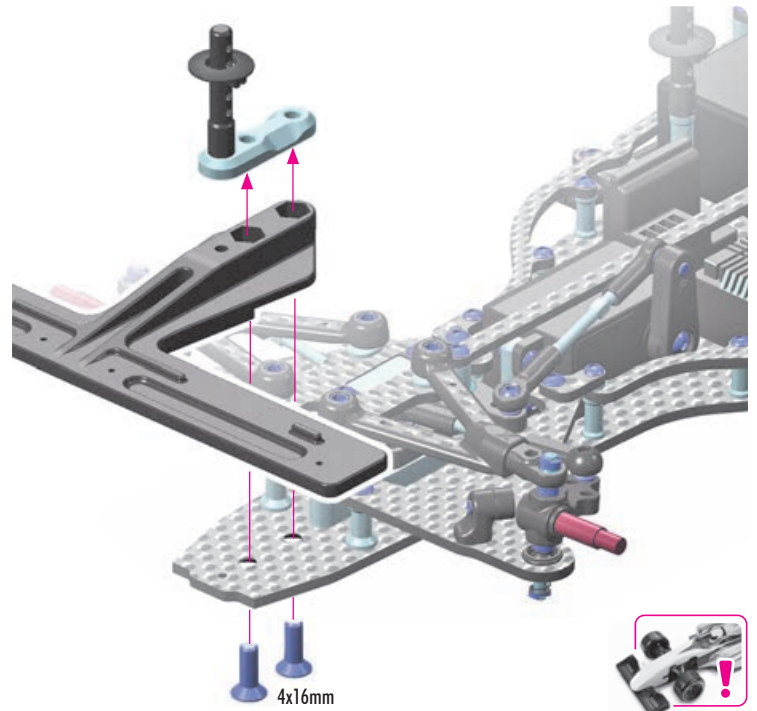

4x16mm

- 1 Before cutting and making holes on the body, put the unpainted body on the chassis to confirm the mounting position and location for holes and cutouts. Before cutting and making holes on the front wing, put the unpainted wing on the front bumper to confirm the mounting position and location for holes and cutouts.
- 2 Before painting, wash the inside of the body with mild detergent, and then rinse and dry thoroughly.
- 3 Mask the helmet shield if you wish.

- 4 Apply paint masks as appropriate.
- 5 Paint the body using paints formulated for polycarbonate bodies.
- 6 When the paint is dry, remove the masking.
- 7 Carefully cut out the body using appropriate scissors or cutting tools.
- 8 When you have finished cutting, peel off the external protective films.

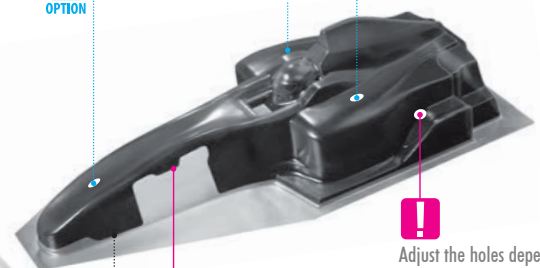
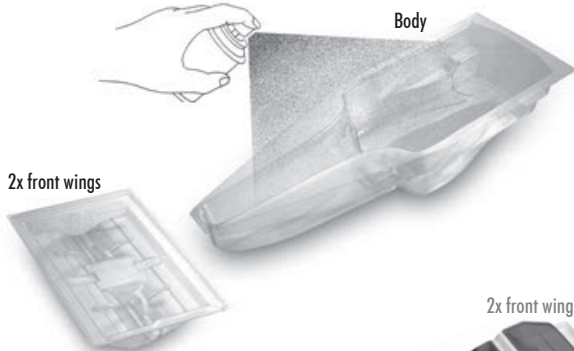

Adjust the holes depending on the rear body posts position.

Adjust the cutting line depending on the front upper arm position.



- Famous Body Fix glue with updated formula
- 50% less glue necessary to apply
- Repairs broken areas
- Fixes damaged/broken bodies
- Strengthens and reinforces weak areas on body
- Fulfills latest EU eco & health safety regulations
- Requires 24 hours to dry

IMPORTANT

Most popular formula bodies will clear the chassis side braces. If a body does not have adequate clearance in the front nose area, installation may require body modification or removal of the side braces.

| OPTION | BODY | | |
|--------|---------|------------------------|--------|
| | #379701 | XRAY | OPTION |
| | #379702 | WORLD CHAMPION EDITION | OPTION |

5. FINAL ASSEMBLY

2x 338586 SHIM 5x7x0.5

4x 902205 SH M2x5

4x 940510 BB 5x10x4

4x 960040 N M4

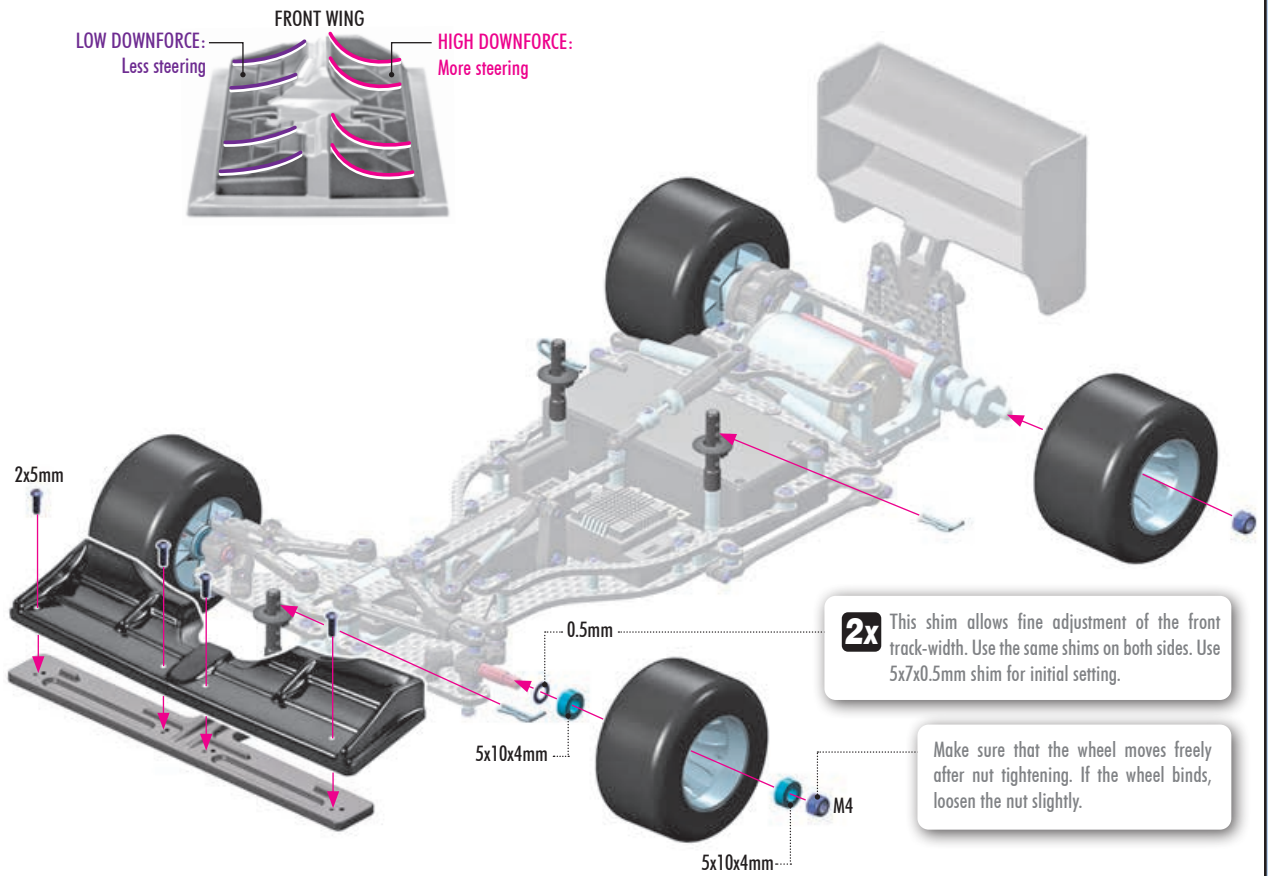

302

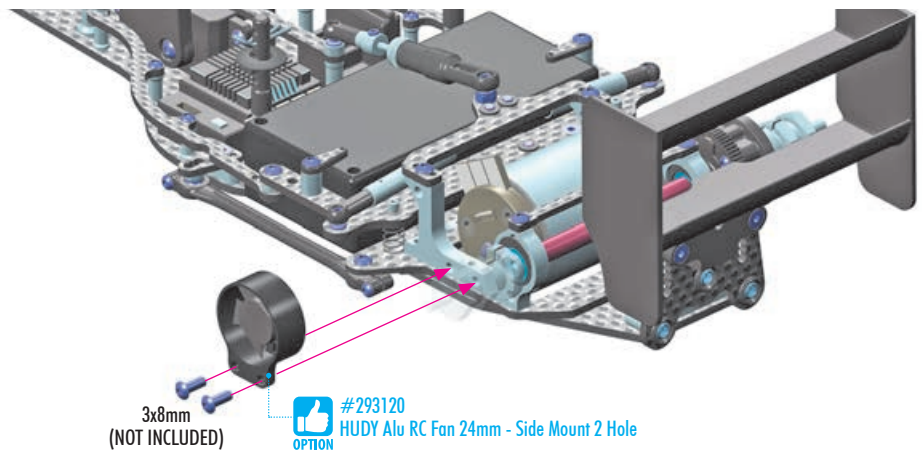

#803072 HUDY 1/10 FORMULA RUBBER TIRE - FRONT (2)
#803082 HUDY 1/10 FORMULA RUBBER TIRE - REAR (2)
OPTION



TRACK-WIDTH ADJUSTMENT SHIMS

| | | |
|---------|-----------|----------|
| #338584 | 5x7x0.2mm | OPTION |
| #338585 | 5x7x0.3mm | OPTION |
| #338586 | 5x7x0.5mm | INCLUDED |



#371204
OPTION
X1 Composite Adjustable Front Wing
White - Flat Design



#371204-K
OPTION
X1 Composite Adjustable Front Wing
Black - Flat Design



#371203
OPTION
X1 Composite Adjustable Front Wing
White - ETS Approved



#371203-K
OPTION
X1 Composite Adjustable Front Wing
Black - ETS Approved



#371202
OPTION
X1 Composite Front Wing Black - ETS Approved



www.teamxray.com

XRAY EUROPE

XRAY, K VÝSTAVISKU 6992, 91101 TRENCIN, SLOVAKIA, EUROPE
PHONE: +421-32-740 11 00, FAX: +421-32-740 11 09, info@teamxray.com

XRAY USA

RC AMERICA, 2030 Century Center Blvd #15, Irving, TX 75062, USA
PHONE: 214-744-2400, FAX: 214-744-2401, xray@rcamerica.com



/TeamXray



/TeamXray



/TeamXray



/TeamXrayRC



/XrayRacing



/XrayRacing